

Instructions for Use

CytoFLEX

Flow Cytometer

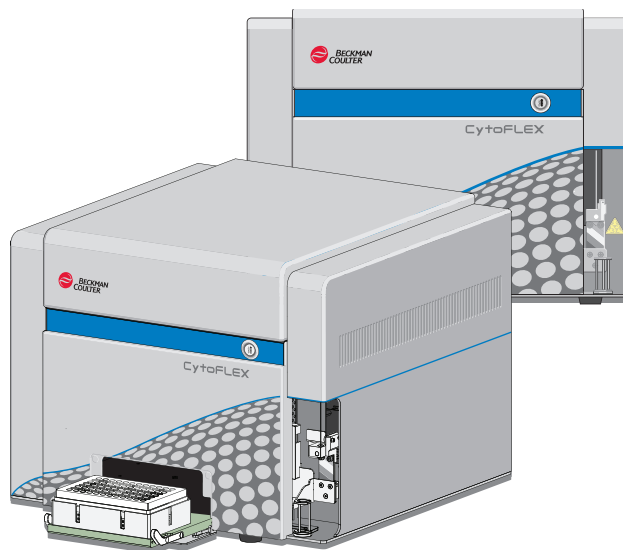

B49006AE
November 2015



Beckman Coulter, Inc.
250 S. Kraemer Blvd.
Brea, CA 92821 U.S.A.



CytoFLEX
Flow Cytometer
PN B49006AE (November 2015)

© 2015 Beckman Coulter, Inc.
All rights reserved.

Beckman Coulter, the stylized logo, CytExpert, and CytoFLEX are trademarks of Beckman Coulter, Inc. Beckman Coulter and the stylized logo are registered in the USPTO.

All other trademarks, service marks, products, or services are trademarks or registered trademarks of their respective holders.

Find us on the World Wide Web at:
www.beckmancoulter.com

Contact Us

If you have any questions, contact our Customer Support Center.

- Worldwide, find us via our website at www.beckmancoulter.com/customersupport/support.
- In the USA and Canada, call us at 1-800-369-0333.
- Outside of the USA and Canada, contact your local Beckman Coulter Representative.

Revision History

Initial Issue AA, 09/2014

Software Version 1.0

Issue AB, 12/2014

Software Version 1.0

Updates were made to the following sections: Symbol Explanations, Figure 1.10, Figure 1.11, Figure 9.3, Figure 9.5, Figure 9.6, Figure 9.7, Disposal Of Electrical Instrumentation, Lifting and Carrying Instructions, Replacing the Sheath Fluid Harness and/or Waste Harness, and Installing the Instrument and Connecting the Equipment.

Issue AC, 02/2015

Software Version 1.1

Updates were made to the following sections:

Safety Notices

- Symbol Explanations

CHAPTER 1, System Overview

- Optical Fiber

- Fluidics Module

- Plate Loader Components

- System Configuration

- Instrument Specifications

- Performance Characteristics

CHAPTER 2, Using the CytExpert Software

- Start Page

- Acquisition Screen

- Test Tubes

- Plot area

- Status Bar

- Analysis Screen

- Compensation Experiment Screen

- QC Experiment Screen

- Software Menu

- Graphic and Gating Styles

- Software Settings

CHAPTER 3, Daily Startup

- Opening the Software

- Selecting the Plate Loader Sample Injection Mode [With Plate Loader]

- Running the System Startup Program

- Running the System Startup Program [With Plate Loader]

This document applies to the latest software listed and higher versions. When a subsequent software version affects the information in this document, a new issue will be released to the Beckman Coulter Web site. For labeling updates, go to www.beckmancoulter.com and download the latest version of the manual or system help for your instrument.

CHAPTER 4, Instrument Quality Control

- Preparing the QC Sample [With Plate Loader]
- Collecting QC Data
- Confirming Results
- Collecting QC Data [With Plate Loader]
- Creating Levey Jennings Charts
- QC Result Manager

CHAPTER 5, Data Acquisition and Sample Analysis

- Creating an Experiment
- Creating an Experiment [With Plate Loader]
- Sampling and Collecting Data
- Setting the Channel and Label
- Adjusting the Threshold
- Creating Plots and Gates
- Setting Customized Parameters
- Setting Custom Statistics
- Analyzing and Exporting Data
- Exporting FCS Files
- Exporting Plots or the Statistics Table of Multiple Tubes as Picture Files
- Printing Graphics

CHAPTER 6, Compensation

- Creating a Compensation Experiment
- Creating a Compensation Experiment [With Plate Loader]
- Manually Adjusting Compensation
- Managing the Compensation Library

CHAPTER 7, Data Review

- Calculating Sample Injection Volume and Concentration
- Importing Previously Acquired Data

CHAPTER 9, Troubleshooting

- Plate Loader Hazard Labels and Location
- Table 9.2, Troubleshooting [With Plate Loader]

CHAPTER 10, Cleaning Procedures

- Daily Clean [With Plate Loader]
- Preparing the Instrument for Transport or Storage

This document applies to the latest software listed and higher versions. When a subsequent software version affects the information in this document, a new issue will be released to the Beckman Coulter Web site. For labeling updates, go to www.beckmancoulter.com and download the latest version of the manual or system help for your instrument.

CHAPTER 11, Replacement/Adjustment Procedures

- Adding the Deep Clean Solution
- Replacing the Sample Probe Assembly [With Plate Loader]
- Changing the Sample Probe from the Single Tube Sample Station to the Plate Loader [With Plate Loader]
- Changing the Sample Probe from the Plate Loader to the Single Tube Sample Station [With Plate Loader]
- Replacing the Plate Holder [With Plate Loader]
- Plate Loader Module Removal and Reinstallation [With Plate Loader]
- Calibrating the Sample Flow Rate
- Calibrating the Sample Flow Rate [With Plate Loader]
- Changing Sample Mixing and Backflush Settings
- Calibrating the Plate Position [With Plate Loader]

APPENDIX A, Instrument Installation

- Power Source
- Unpacking the Instrument and Inspecting the Materials for Defects or Omissions
- Installing the CytExpert Software

Issue AD, 04/2015

Software Version 1.1

Updates were made to the following sections:

CHAPTER 1, System Overview

Cytometer

CHAPTER 2, Using the CytExpert Software

Analysis Screen

CHAPTER 8, Daily Shutdown

Shutting Down the Instrument

CHAPTER 11, Replacement/Adjustment Procedures

- Changing the Event Rate Setting
- Calibrating the Plate Position [With Plate Loader]

Issue AE, 11/2015

Software Version 1.1

Updates were made to the following sections:

CHAPTER 1, System Overview

- Plate Loader Components
- Plate Holder Components
- Dimensions
- Acoustic Noise Level
- Performance Characteristics

CHAPTER 4, Instrument Quality Control

Confirming Results

This document applies to the latest software listed and higher versions. When a subsequent software version affects the information in this document, a new issue will be released to the Beckman Coulter Web site. For labeling updates, go to www.beckmancoulter.com and download the latest version of the manual or system help for your instrument.

CHAPTER 9, Troubleshooting

Plate Loader Hazard Labels and Location

CHAPTER 10, Cleaning Procedures

Daily Clean

Daily Clean [With Plate Loader]

Preparing the Instrument for Transport or Storage

CHAPTER 11, Replacement/Adjustment Procedures

Replacing the Sample Probe Assembly [With Plate Loader]

Replacing the Plate Holder [With Plate Loader]

Plate Loader Module Removal and Reinstallation [With Plate Loader]

APPENDIX A, Instrument Installation

Installing the Instrument and Connecting the Equipment

Note: Changes that are part of the most recent revision are indicated in text by a red bar in the margin of the amended page.

This document applies to the latest software listed and higher versions. When a subsequent software version affects the information in this document, a new issue will be released to the Beckman Coulter Web site. For labeling updates, go to www.beckmancoulter.com and download the latest version of the manual or system help for your instrument.

Safety Notices

Read all product manuals and consult with Beckman Coulter-trained personnel before attempting to operate instrument. Do not attempt to perform any procedure before carefully reading all instructions. Always follow product labeling and manufacturer's recommendations. If in doubt as to how to proceed in any situation, contact your Beckman Coulter Representative.

Beckman Coulter, Inc. urges its customers to comply with all national health and safety standards such as the use of barrier protection. This may include, but it is not limited to, protective eyewear, gloves, and suitable laboratory attire when operating or maintaining this or any other automated laboratory analyzer.

This manual assumes that users have basic knowledge of the Windows operating system, as well as experience working with laboratory testing technology. Users are invited to consult the appropriate documentation for such information.

Alerts for Danger, Warning, and Caution



DANGER indicates an imminently hazardous situation which, if not avoided, will result in death or serious injury.



WARNING indicates a potentially hazardous situation which, if not avoided, could result in death or serious injury.



CAUTION indicates a potentially hazardous situation, which, if not avoided, may result in minor or moderate injury. It may also be used to alert against unsafe practices.

Safety Precautions

WARNING

Risk of operator injury if:

- All doors, covers and panels are not closed and secured in place prior to and during instrument operation.
- The integrity of safety interlocks and sensors is compromised.
- Instrument alarms and error messages are not acknowledged and acted upon.
- You contact moving parts.
- You mishandle broken parts.
- Doors, covers and panels are not opened, closed, removed and/or replaced with care.
- Improper tools are used for troubleshooting.

To avoid injury:

- Keep doors, covers and panels closed and secured in place while the instrument is in use.
- Take full advantage of the safety features of the instrument.
- Acknowledge and act upon instrument alarms and error messages.
- Keep away from moving parts.
- Report any broken parts to your Beckman Coulter Representative.
- Open/remove and close/replace doors, covers and panels with care.
- Use the proper tools when troubleshooting.

CAUTION







System integrity could be compromised and operational failures could occur if:

- This equipment is used in a manner other than specified. Operate the instrument as instructed in the product manuals.
- You introduce software that is not authorized by Beckman Coulter into your computer. Only operate your system's software with software authorized by Beckman Coulter.
- You install software that is not an original copyrighted version. Only use software that is an original copyrighted version to prevent virus contamination.

CAUTION

If you purchased this product from anyone other than Beckman Coulter or an authorized Beckman Coulter distributor, and, it is not presently under a Beckman Coulter service maintenance agreement, Beckman Coulter cannot guarantee that the product is fitted with the most current mandatory engineering revisions or that you will receive the most current information bulletins concerning the product. If you purchased this product from a third party and would like further information concerning this topic, contact your Beckman Coulter Representative.

Symbol Explanations

Symbol meanings	
	Caution / Warning
	Electrical shock hazard. Operate with caution!
	Possible laser radiation inside.
	Biohazard
	Potential pinch point. ^a
	Potential puncture hazard. ^a
	CE = Conformité Européenne A “CE” mark indicates that a product has been assessed before being placed on the market, and has been found to meet European Union safety, health, and/or environmental protection requirements. It is a mandatory marking for various product categories that are placed into service within the European Economic area.

a. This label only appears on the Plate Loader Module.

Contents

Revision History, iii

Safety Notices, vii

Alerts for Danger, Warning, and Caution, vii

Safety Precautions, viii

Symbol Explanations, ix

Introduction, xxi

Overview, xxi

How to Use Your Manual, xxi

About this Manual, xxi

Conventions Used, xxii

Graphics, xxiii

CHAPTER 1: System Overview, 1-1

Overview, 1-1

Product Description, 1-1

Main Components, 1-1

Optical Components, 1-2

Wavelength Division Multiplexer (WDM), 1-3

Optical Fiber, 1-6

Fluidics System, 1-7

Fluid Containers, 1-8

Fluidics Module, 1-9

Sample Station, 1-11

Sample Tube Holder Positions, 1-11

Plate Loader Components, 1-13

Plate Holder Components, 1-15

System Configuration, 1-17

Consumables and Supplies, 1-19

Reagents, 1-19

Material Safety Data Sheets (SDS/MSDS), 1-19

Ordering Information, 1-19

Instrument Specifications, 1-20

- Dimensions, 1-20
- Installation Category, 1-20
- Pollution Degree, 1-20
- Acoustic Noise Level, 1-20
- Electrical Ratings, 1-20
- Cytometer, 1-20

Performance Characteristics, 1-22

Reagent Limitations, 1-23

CHAPTER 2: Using the CytExpert Software, 2-1

Overview, 2-1

Launching the Software, 2-1

Main Software Screen, 2-1

- Start Page, 2-2

- Acquisition Screen, 2-3

- Acquisition Screen Navigation, 2-4

- Collection, 2-5

- Collection [With Plate Loader], 2-6

- Test Tubes, 2-7

- Plot area, 2-8

- Status Bar, 2-9

- Analysis Screen, 2-9

- Compensation Experiment Screen, 2-10

- QC Experiment Screen, 2-11

- QC Settings Screen, 2-11

- QC Experiment Screen, 2-12

- QC Screen Navigation, 2-13

- Software Menu, 2-14

- Acquisition and Analysis Screen Menu, 2-15

Graphic and Gating Styles, 2-18

- Plots, 2-18

- Gates, 2-19

Software Settings, 2-20

CHAPTER 3: Daily Startup, 3-1

Overview, 3-1

Pre-Startup Inspection, 3-1

- Check Waste and Reagent Levels, 3-2

- Power Source Inspection, 3-4

- Workstation Connections Inspection, 3-4

Turning On the Instrument, 3-4

Opening the Software, 3-4

- Selecting the Proper Sample Injection Mode, 3-6

- Using Semi-Automatic Injection Mode, 3-7

- Using the Manual Injection Mode, 3-8
- Selecting the Plate Loader Sample Injection Mode [With Plate Loader], 3-9
 - Using Plate Loader Injection Mode, 3-10
- Running the System Startup Program, 3-12
- Running the System Startup Program [With Plate Loader], 3-15
- Selecting Experiments from the Start Page, 3-22

Initializing the Instrument, 3-23

CHAPTER 4: Instrument Quality Control, 4-1

Overview, 4-1

Preparing the QC Sample, 4-2

- Required materials, 4-2
- Preparation process, 4-2

Preparing the QC Sample [With Plate Loader], 4-3

- Required Materials, 4-3
- Preparation Process, 4-3

Importing Lot-Specific Target Values, 4-4

Collecting QC Data, 4-8

Collecting QC Data [With Plate Loader], 4-10

Confirming Results, 4-14

- Creating Levey Jennings Charts, 4-17
- QC Result Manager, 4-20

CHAPTER 5: Data Acquisition and Sample Analysis, 5-1

Overview, 5-1

Creating an Experiment, 5-1

Creating an Experiment [With Plate Loader], 5-3

- Setting Sample Wells, 5-5
 - Modifying Well Settings, 5-9
 - Applying Existing Well Settings to Additional Wells, 5-10
 - Copying, Cutting, and Pasting Wells, 5-10
 - Moving the Location of a Well, 5-11
- Running Samples, 5-11

Load Sample and Record Data, 5-13

- Before Running Samples, 5-13
- Verifying, Selecting, Editing, and Creating Detector Configuration, 5-13
 - Setting Up Violet Side Scatter (VSSC) Channel, 5-18
- Sampling and Collecting Data, 5-21

Configuring Acquisition Settings, 5-25

- Changing the Tube Name, 5-25
- Setting the Channel and Label, 5-25

- Creating Plots and Gates, 5-27
- Adjusting the Gain, 5-36
- Adjusting the Threshold, 5-37
- Setting Collection Conditions, 5-39
- Setting Customized Parameters, 5-40
- Setting Custom Statistics, 5-41
- Analyzing and Exporting Data, 5-44
 - Exporting FCS Files, 5-49
 - Exporting Single Tube Files, 5-49
 - Exporting Multiple FCS Files, 5-51
 - Exporting Plots or the Statistics Table of Multiple Tubes as Picture Files, 5-52
 - Importing and Exporting Instrument Settings, 5-53
 - Importing Instrument Settings, 5-53
 - Exporting Instrument Settings, 5-54
 - Importing and Exporting Compensation Settings, 5-54
 - Printing Graphics, 5-54
- Saving the Experiment, 5-56
 - Concluding the Experiment, 5-57

CHAPTER 6: Compensation, 6-1

- Overview, 6-1
- Creating a Compensation Experiment, 6-2
 - Preparing the Compensation Sample, 6-4
 - Using Control Samples to Generate the Compensation Matrix, 6-4
 - Defining the Negative Population Using Unstained Samples, 6-4
 - Running the Single Positive Control Samples, 6-6
 - Calculating Compensation Values, 6-8
- Creating a Compensation Experiment [With Plate Loader], 6-10
 - Preparing the Compensation Sample, 6-12
 - Using Control Samples to Generate the Compensation Matrix, 6-13
 - Calculating Compensation Values, 6-13
- Creating the Compensation Matrix from Previously Acquired Data, 6-14
- Adjusting Compensation, 6-15
 - Manually Adjusting Compensation, 6-15
 - Importing and Exporting Compensation, 6-16
 - Importing Compensation Settings from Compensation Matrix Files, 6-16
 - Importing Compensation Settings from the Compensation Library, 6-17
 - Exporting Compensation Settings, 6-18
 - Managing the Compensation Library, 6-20
 - Adding Channels for Compensation, 6-21

CHAPTER 7: Data Review, 7-1

- Overview, 7-1

- Copying Experiments and Importing Data, 7-1
 - Copying a Previously Acquired Experiment, 7-1
 - Importing Previously Acquired Data, 7-1
- Setting the Plots and Statistics, 7-3
 - Opening the Analysis Screen, 7-3
 - Creating Multi-Data Histograms and Dot Plot Overlays, 7-5
- Calculating Sample Injection Volume and Concentration, 7-6
- Adjusting Compensation Settings, 7-7
- Exporting Results, 7-7

CHAPTER 8: Daily Shutdown, 8-1

- Overview, 8-1
- Preparing the Cleaning Solution, 8-1
- Shutting Down the Instrument, 8-1

CHAPTER 9: Troubleshooting, 9-1

- Overview, 9-1
- Precautions/Hazards, 9-1
 - Laser Related Hazards, 9-1
 - Laser Beam Hazards, 9-2
 - Laser Warning Labels, 9-2
- Hazard Labels and Locations, 9-4
 - Biohazard Label and Location, 9-4
 - Electrical Shock Hazard Label and Location, 9-5
 - Caution Labels and Location, 9-5
 - Plate Loader Hazard Labels and Location, 9-6
 - Disposal Of Electrical Instrumentation, 9-6
- RoHS Notice, 9-7
 - RoHS Caution Label, 9-7
 - RoHS Environmental Label, 9-7
- Disposal Precaution, 9-7
- Troubleshooting Table, 9-8

CHAPTER 10: Cleaning Procedures, 10-1

- Overview, 10-1
- Routine Cleaning, 10-1
 - Daily Clean, 10-1
 - Daily Clean [With Plate Loader], 10-4
 - Cleaning the Sample Station, 10-5
 - Cleaning the Sample Probe, 10-6
 - Deep Clean Procedure, 10-7
 - Cleaning the Sheath Fluid Container, 10-9

Cleaning the Waste Container, 10-10

Nonscheduled Cleaning, 10-12

Preparing the Instrument for Transport or Storage, 10-12

Lifting and Carrying Instructions, 10-15

CHAPTER 11: Replacement/Adjustment Procedures, 11-1

Overview, 11-1

Routine Replacement/Adjustment, 11-2

Front Cover Removal and Reinstallation, 11-2

Removal, 11-2

Reinstallation, 11-3

Right-Side Cover Removal and Reinstallation, 11-4

Removal, 11-4

Reinstallation, 11-4

Filling the Sheath Fluid Container, 11-5

Emptying the Waste Container, 11-6

Managing the Maintenance Reminder, 11-7

Adding the Deep Clean Solution, 11-10

Replacing the Sheath Fluid Filter, 11-12

Replacing the Sample Probe and/or the Sample Peristaltic Pump
Tubing, 11-16

Replacing the Sample Probe Assembly [With Plate Loader], 11-21

Changing the Sample Probe from the Single Tube Sample Station to
the Plate Loader [With Plate Loader], 11-27

Changing the Sample Probe from the Plate Loader to the Single
Tube Sample Station [With Plate Loader], 11-32

Inspecting the Liquid Flow Path for Leaks, 11-35

Priming the Flow Cell, 11-36

Replacing the Plate Holder [With Plate Loader], 11-38

Plate Loader Module Removal and Reinstallation [With Plate
Loader], 11-39

Removal, 11-39

Installation, 11-43

Changing the Event Rate Setting, 11-48

Nonscheduled Replacement/Adjustment, 11-49

Calibrating the Sample Flow Rate, 11-49

Calibrating the Sample Flow Rate [With Plate Loader], 11-52

Setting Laser Delay, 11-56

Replacing the Optical Filter, 11-57

Replacing the Fuse, 11-60

Replacing the Sheath Fluid Harness and/or Waste Harness, 11-62

Changing Sample Mixing and Backflush Settings, 11-64

Calibrating the Plate Position [With Plate Loader], 11-66

APPENDIX A: Instrument Installation, A-1

Overview, A-1

Instrument Transportation and Storage, A-1

Installation Environment Validation, A-1
Worktable, A-2
Ventilation and Cleaning, A-2
Power Source, A-3
Temperature and Humidity, A-4
Waste Disposal, A-4
Unpacking the Instrument and Inspecting the Materials for Defects or Omissions, A-4
Installing the Instrument and Connecting the Equipment, A-5
Installing the Software, A-11
Required materials, A-12
Installing the CytExpert Software, A-12
Installing the Instrument Configuration File, A-21
Starting the Software, A-23

APPENDIX B: Table of Hazardous Substances, B-1

Table of Hazardous Substances, B-1

Abbreviations

Index

Beckman Coulter, Inc.

Customer End User License Agreement

Related Documents

Illustrations

- 1.1 Optical Filter Mounts, 1-4
- 1.2 Optical Filter Mount with Optical Filter, 1-4
- 1.3 Optical Filter Mount Labeled with the Band-Pass Information, 1-4
- 1.4 Optical Filter Mount (Top), 1-5
- 1.5 Fluid Containers, 1-8
- 1.6 Fluidics Module View, 1-9
- 1.7 Fluidic Connections, 1-10
- 1.8 Sample Station, 1-11
- 1.9 Sample Tube Holder Positions, 1-12
- 1.10 Plate Loader, 1-13
- 1.11 Plate Loader (Front Cover Removed), 1-14
- 1.12 Plate Holder (Top View on Left; Bottom View on Right), 1-15
- 1.13 Plate Holder Stage, 1-16
- 1.14 System Connections, 1-17
- 1.15 Back Cover Connections, 1-18
- 1.16 Front of Cytometer, 1-18
- Semi-Automatic Sample Injection Mode Shown, 2-9
- 2.1 Drawing Controls Toolbar (Top of Screen), 2-10
- Semi-Automatic Sample Injection Mode Shown, 2-11
- Semi-Automatic Sample Injection Mode Shown, 2-12
- 2.2 Software Menu Tree*, 2-14
- 2.3 QC Software Menu Tree, 2-15
- System Startup Program Window in Semi-Automatic Injection Mode, 3-13
- System Startup Program Window in Manual Injection Mode, 3-13
- 5.1 Plate Window, 5-5
- 6.1 Before Compensation, 6-1
- 6.2 After Compensation, 6-1
- 6.3 Positive Population Selected from the Unstained Sample, 6-7
- 6.4 Positive and Negative Populations Without an Unstained Sample, 6-8
- 9.1 Laser Warning Label on the Laser Optical Bench, 9-3

- 9.2 Laser Warning Label within the Optical Bench (Located Inside the Cytometer), 9-3
- 9.3 Laser Warning Labels on the Cytometer Back Cover, 9-4
- 9.4 Biohazard Label on the Fluid Containers, 9-4
- 9.5 Biohazard Label Located in the Sample Station and on the Back of the Cytometer, 9-5
- 9.6 Electrical Shock Hazard Label by the Power Switch, 9-5
- 9.7 Caution Labels, 9-5
- 9.8 Plate Loader Hazard Labels, 9-6
- 11.1 Plate Holder Stage, 11-38
- 11.2 Removing the Tubings from the Fluidics Module to the Plate Loader, 11-42
- 11.3 Plate Loader Module Securing Screws, 11-43
- 11.4 Removing the Plate Loader from the Cytometer, 11-43
- 11.5 Installing the Plate Loader in to the Cytometer, 11-44
- 11.6 Plate Loader Module Securing Screws, 11-44
- 11.7 Connecting the Tubings from the Fluidics Module to the Plate Loader, 11-45

Tables

1.1	WDM Optical Filter Mount Color Codes, 1-5
9.1	Troubleshooting, 9-8
9.2	Troubleshooting [With Plate Loader], 9-19
B.1	Table of Hazardous Substances Name and Concentration, B-2

Overview

This introduction contains the following information:

- [How to Use Your Manual](#)
- [About this Manual](#)
- [Conventions Used](#)
- [Graphics](#)

How to Use Your Manual

Your CytoFLEX flow cytometer system includes the manuals listed below:

- Use this **Instructions for Use** manual for information on the day-to-day operation of your CytoFLEX flow cytometer. You can find detailed step-by-step procedures for Daily Startup and Quality Control, configuring settings, running samples, analyzing data, and performing Startup and Shutdown. This manual also contains physical and system specifications, safety and troubleshooting information, as well as information about what your CytoFLEX flow cytometer does and the methods it uses. It also contains procedures for cleaning and replacement.
- The **Quick Start Guide** provides an abbreviated version of the Operating Instructions.
- The **CytoFLEX Setup Guide** provides instructions for unpacking and setting up the CytoFLEX flow cytometer system.

About this Manual

The information in your Instructions for Use manual is organized as follows:

CHAPTER 1, System Overview

Provides information regarding the individual components of the CytoFLEX flow cytometer and the corresponding functions of these components.

CHAPTER 2, Using the CytExpert Software

Provides an overview of each aspect of the software's functions.

CHAPTER 3, Daily Startup

Provides instructions for starting your CytoFLEX flow cytometer and navigating to the sample testing standby state.

CHAPTER 4, Instrument Quality Control

Provides instructions for performing daily quality control (QC) on your CytoFLEX flow cytometer to confirm the instrument is working correctly and to ensure accurate experimental data. Quality control allows you to determine whether your instrument can provide adequate signal strength and precision.

CHAPTER 5, Data Acquisition and Sample Analysis

Provides instructions for operating the CytoFLEX instrument, including data acquisition, analyzing and exporting results, and manually adjusting the compensation during the acquisition and analysis.

CHAPTER 6, Compensation

Describes how to create a compensation experiment and automatically calculate compensation values after acquiring the data. It also explains how to use these calculations for other experiments.

CHAPTER 7, Data Review

Describes how to use the Analysis screen to analyze data that has already been acquired through the instrument.

CHAPTER 8, Daily Shutdown

Describes how to keep the instrument in optimal condition through daily cleaning during the shutdown procedure.

CHAPTER 9, Troubleshooting

Describes some common problems and their solutions in a basic troubleshooting matrix.

CHAPTER 10, Cleaning Procedures

Describes how to carry out certain routine and nonscheduled cleaning procedures.

CHAPTER 11, Replacement/Adjustment Procedures

Describes how to carry out certain routine and nonscheduled replacement and adjustment procedures.

APPENDIX A, Instrument Installation

Provides the instrument installation procedures for your CytoFLEX flow cytometer.

APPENDIX B, Table of Hazardous Substances

Provides the table of hazardous substances with the hazardous substance name and concentration.

Conventions Used

This document uses the following conventions:

- **Bold face** font indicates buttons or selections that appear on the workstation screen.
- The term “select” is used to indicate the following action:
 - To click with a mouse.

NOTE The verb “press” is reserved for mechanical buttons, such as keys on the keyboard.

- The software path to a specific function or screen appears with the greater than (>) symbol between screen options.
- Links to information in another part of the document for additional information are in blue and are underlined. To access the linked information, select the blue, underlined text.
- Sections that contain entirely new content are flagged with a New Section icon  at the end of the section title.
- The information in your Instructions for Use manual applies to both CytoFLEX instruments equipped with a plate loader and CytoFLEX instruments not equipped with a plate loader unless otherwise specified.

NOTE When information in this document only applies to the plate loader configuration, it is marked [With Plate Loader].

IMPORTANT IMPORTANT is used for comments that add value to the step or procedure being performed. Following the advice in the IMPORTANT adds benefit to the performance of a piece of equipment or to a process.

NOTE NOTE is used to call attention to notable information that should be followed during use, or maintenance of this equipment.

Graphics

All graphics, including screens and printouts, are for illustration purposes only and must not be used for any other purpose. For example, software screens that show the CytoFLEX system in the background may not depict the latest production version of the system.

Overview

This chapter describes the individual components of the CytoFLEX flow cytometer and the corresponding functions of these components.

This chapter contains information on:

- [Product Description](#)
- [Main Components](#)
- [Optical Components](#)
- [Fluidics System](#)
- [Sample Station](#)
- [Plate Loader Components](#)
- [System Configuration](#)
- [Consumables and Supplies](#)
- [Instrument Specifications](#)
- [Performance Characteristics](#)
- [Reagent Limitations](#)

Product Description

The CytoFLEX flow cytometer is used for the qualitative and quantitative measurement of biological and physical properties of cells and other particles. These properties are measured when the cells pass through one or multiple laser beams in a single-file. The CytoFLEX flow cytometer can perform up to 13 color marker analysis. The system can be ordered in various configurations from a 1 laser, 4 colors, to a maximum of 4 lasers, 13 colors. Any one of the configurations can be upgraded in the field. For Research Use Only. Not for use in diagnostics procedures.

Main Components

 **CAUTION**

Risk of instrument damage and/or instrument stability. Do not place any objects on top of the instrument, as this could cause warping of the top cover or affect the stability of the optical path.

The instrument consists of three main components: Fluid Containers, Cytometer, and the Workstation.

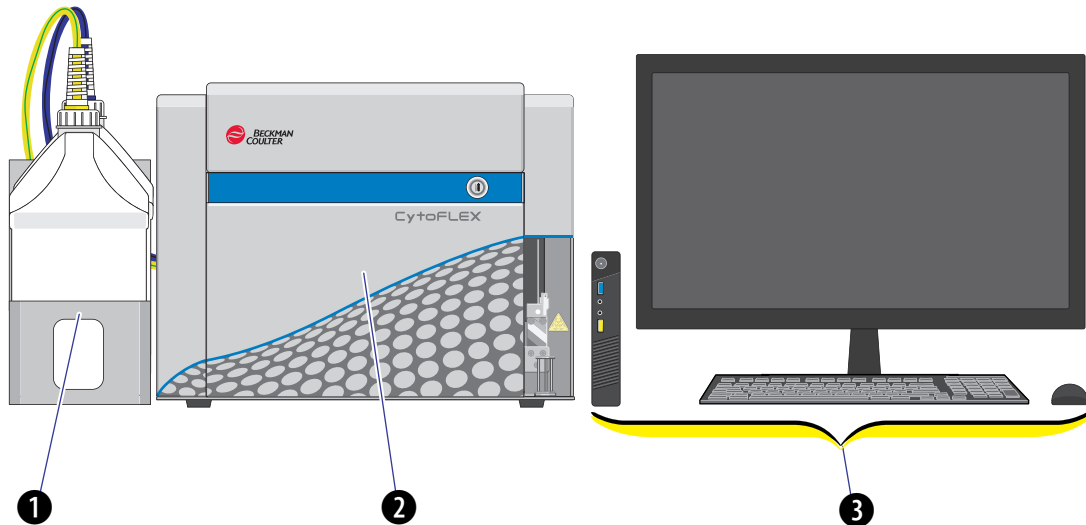

1. **Fluid Containers.** Accommodates sheath fluid and waste liquids as required for operation of the instrument.
2. **Cytometer.** Provides signal generation and collection.
3. **Workstation.** Displays and manipulates the contents of the Workstation and displays data generated by the Cytometer.

Optical Components

 **CAUTION**

Risk of operator injury. When operating the instrument, keep the top cover in the closed position to prevent the top cover from falling. When opening the top cover, be cautious to avoid any possible pinch points.

The optical components are located in the upper portion of the Cytometer and are visible when the top cover is open. Three parts are included: an optical bench, detector arrays also known as wavelength division multiplexers (WDMs), and optical fibers. Optical components include

equipment such as lasers and signal detectors that are used to excite, transmit, and collect optical signals.

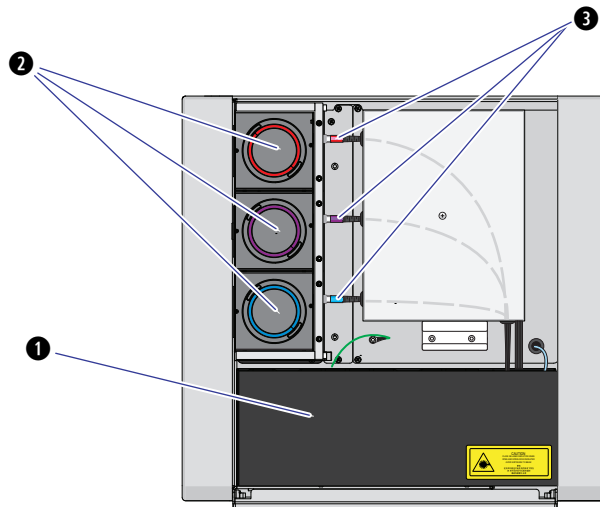

1. **Optical bench.** Includes laser light sources, an optical beam combiner, and an integrated optics flow cell assembly. The optical bench cover is equipped with a laser interlock that turns the lasers off unless the cover is tightly closed.
2. **Wavelength division multiplexer (WDM).** Each WDM is a unique detector array that corresponds to a different laser. Each WDM contains optical filters and detectors for detecting channel fluorescence or scatter from a particular laser. It is necessary to ensure that the filter and software settings match for each channel.
3. **Optical fiber.** Transmits emitted fluorescence specific to laser path.

Wavelength Division Multiplexer (WDM)

Each WDM corresponds to a different laser. The color of the ring on each cap corresponds to the color of the respective laser. Pressing the two release buttons on opposite edges of the cap allows you to open the unit and replace the filters inside. See [Figure 1.1](#). All optical filters are designed to

be interchangeable. Refer to [Replacing the Optical Filter](#) in [CHAPTER 11, Replacement/Adjustment Procedures](#), to replace an optical filter.

Figure 1.1 Optical Filter Mounts

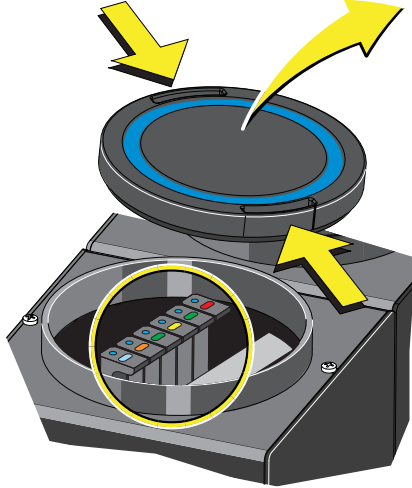

Each optical filter mount has an optical filter glass piece. See [Figure 1.2](#).

Figure 1.2 Optical Filter Mount with Optical Filter

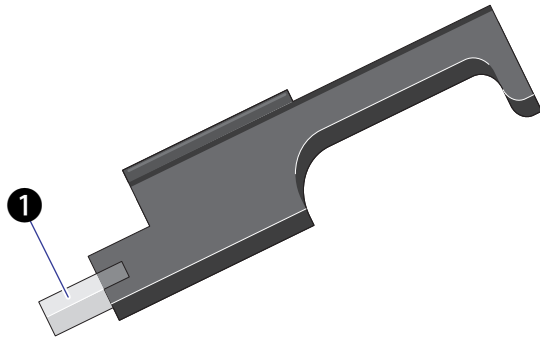

1. Optical filter glass piece

Each optical filter mount is labeled with the corresponding laser and band-pass information. See [Figure 1.3](#).

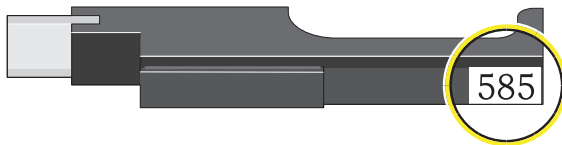

Figure 1.3 Optical Filter Mount Labeled with the Band-Pass Information

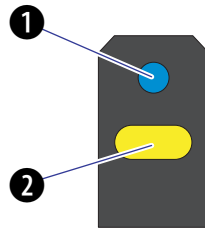

The top of each optical filter mount has two marks. The color of the dot (1) indicates the color of the laser. See Figure 1.4. The color of the line (2) indicates the wavelength range of the optical band-pass filter. See Figure 1.4.

Figure 1.4 Optical Filter Mount (Top)



1.  . Indicates corresponding laser color: Blue indicates a 488 nm laser; Red indicates a 638 nm laser; Violet indicates a 405 nm laser.
2.  . Indicates the band-pass wavelength ranges; the specific wavelength is indicated numerically on the lateral side of the mount.

Band-pass filters are used to transmit fluorescence at the specific wavelength ranges. These ranges are designed to measure fluorescence from the fluorochromes such as those listed in Table 1.1. (with red and violet laser upgrades installed) that are excited by the lasers. You can change the optical filters according to your detector configuration. There is no need to realign the optical system when the filters are changed.

Table 1.1 WDM Optical Filter Mount Color Codes

















Lasers	Fluorescent Channel	CytoFLEX Channel Names	Commonly used Fluorescent Dyes
 488-nm	 525/40 BP	FITC	FITC, Alexa Fluor™ 488, CFSE, Fluo-3
	 585/42 BP	PE	PE, PI
	 610/20 BP	ECD	ECD, PE-Texas Red®, PE-CF594, PI
	 690/50 BP	PC5.5	PC5.5, PC5, PerCP, PerCP-Cy5.5, PI
	 780/60 BP	PC7	PC7
 638-nm	 660/20 BP	APC	APC, Alexa Fluor™ 647, eFluor™ 660
	 712/25 BP	APC-A700	APC-A700, Alexa Fluor™ 700
	 780/60 BP	APC-A750	APC-A750, APC-Cy7, APC-H7, APC- eFluor™ 780

Table 1.1 WDM Optical Filter Mount Color Codes (Continued)

Lasers	Fluorescent Channel	CytoFLEX Channel Names	Commonly used Fluorescent Dyes
 405-nm	 450/45 BP	PB450	Pacific Blue™ dye, V450, eFluor™ 450, BV421
	 525/40 BP	KO525	Krome Orange, AmCyan, V500, BV510
	 610/20 BP	Violet610	BV605, Qdot® 605
	 660/20 BP	Violet660	BV650, Qdot® 655
	 780/60 BP	Violet780	BV785, Qdot® 800

Optical Fiber



Risk of data integrity damage.

- **During use, verify that the optical fibers are securely connected to the WDM. A loose connection can alter the optical path and affect fluorescence detection.**
- **Do not disconnect the fiber as this could contaminate the tip and weaken the signal.**

Fluorescence emitted by laser-excited fluorochromes is picked up and delivered by each optical fiber to the corresponding detector module. Each optical fiber has a colored ring on the end that

connects to the WDM, indicating the color of the corresponding laser. Ensure that the correct fiber is properly connected to the corresponding WDM.

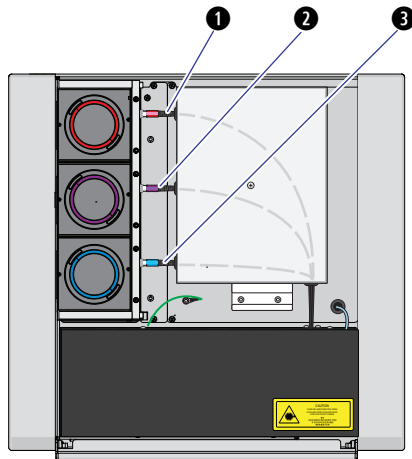

1. Red laser fiber
2. Violet laser fiber
3. Blue laser fiber

Fluidics System

The fluidics system consists of two parts: the Fluid Containers and the Fluidics module. The Fluidics module is located on the right side of the Cytometer. You need to open the right-side cover of the instrument (see [Right-Side Cover Removal and Reinstallation](#) in [CHAPTER 11, Replacement/Adjustment Procedures](#)) to perform maintenance operations. The fluidics system helps to transmit

the sheath fluid at a stable rate into the flow cell, forming a laminar fluidics system that ensures that the tested particles go through the detection area sequentially.

Figure 1.5 Fluid Containers

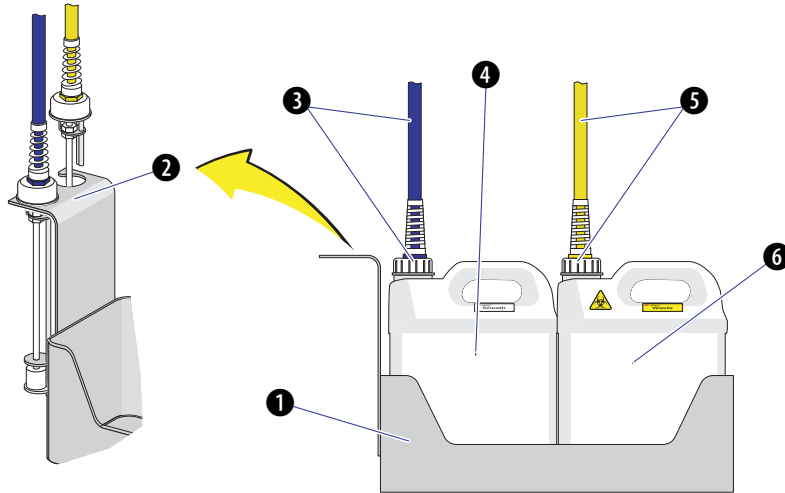

- 1. Fluid Container holder.** Holds the Fluid Containers.
- 2. Fluid sensor holder cutout.** Holds the sheath fluid harness and the waste harness when removed from their respective containers to protect the sensors from damage and/or contamination.
- 3. Sheath fluid harness.** Connects to the sheath fluid container; conveys the sheath fluid into the instrument. The sheath fluid harness includes the a level sensor, sheath fluid tubing, and backflush tubing. The other end of the harness is connected to the Fluidics module in the Cytometer. When the sheath fluid container is near empty, a warning notice is transmitted to the instrument and an audible signal sounds as a warning.
- 4. Sheath fluid container.** 4 L capacity, for holding sheath fluid. Beckman Coulter recommends using CytoFLEX Sheath Fluid or a similar nonionic strength sheath fluid to ensure system performance.
- 5. Waste harness.** Connects to the waste fluid container; conveys the waste fluid from the instrument to the waste container. The waste harness includes a level sensor. The other end of the harness is connected to the Fluidics module in the Cytometer. When the waste fluid container is near full, a warning notice is transmitted to the instrument and audible signal sounds as a warning.
- 6. Waste container.** 4 L capacity, for holding waste liquids. Attention to biosafety and waste labeling is required.

Fluid Containers

Two Fluid Containers are placed in the Fluid Container holder: a sheath fluid container and a waste container. See [Figure 1.5](#). Each container cap is fitted with a harness and a level sensor. The blue harness connects to the sheath fluid container, while the yellow harness connects to the waste container. The containers do not require additional pressure inside. Take all necessary biosafety precautions and use proper personal protective equipment when using the Fluid Containers.

Fluidics Module

The Fluidics module is on the right side of the Cytometer. To access it, you must first open the right-side cover. Refer to [Right-Side Cover Removal and Reinstallation](#) in [CHAPTER 11, Replacement/Adjustment Procedures](#). Inside the module, in addition to working pumps, valves, and tubing, there is a sheath filter and a Deep Clean solution bottle. During maintenance, it may be necessary to replace the filter (see [Replacing the Sheath Fluid Filter](#) in [CHAPTER 11, Replacement/Adjustment Procedures](#)) or to add Deep Clean solution (see [Adding the Deep Clean Solution](#) in [CHAPTER 11, Replacement/Adjustment Procedures](#)).

Figure 1.6 Fluidics Module View

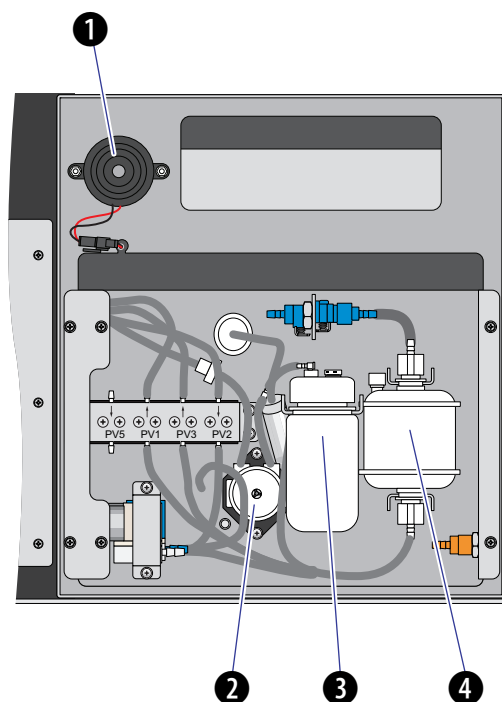

1. **Alarm.** Emits a warning sound when there is a problem with the Fluid Container capacity or with the performance of certain operations.

NOTE When the alarm sounds, the Mute Alerter icon appears in the status bar. The alarm continues for about 30 seconds. To mute the alarm temporarily select the **Mute Alerter** in the status bar. The icon disappears when the waste container is emptied and/or the sheath container is filled.



2. **Deep Clean solution peristaltic pump.** Transfers cleaning solution to the flow cell based on flow rate settings.
3. **Deep Clean solution bottle.** Contains the diluted cleaning solution that helps to clean the flow cell.
4. **Sheath fluid filter.** 0.2 μm filter, for filtering sheath fluid.

Figure 1.7 Fluidic Connections

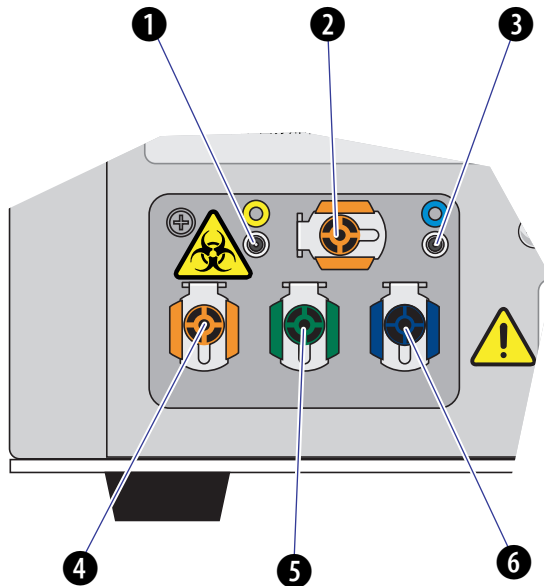

1. **Waste level sensor connector.** Connects to the waste liquid sensor cable.
2. **Flow cell waste out.** Connects to the waste tubing of the wash station.
3. **Sheath fluid level sensor connector.** Connects to the sheath fluid sensor cable.
4. **Waste out.** Connects to the waste liquid tubing from the flow cell.
5. **Sheath return.** Connects to the sheath fluid tubing.
6. **Sheath fluid in.** Connects to the sheath fluid tubing.

NOTE Use CytoFLEX Sheath Fluid or other filtered nonionic strength sheath fluid. Using unfiltered sheath fluid can shorten the service life of the sheath fluid filters and increase noise and debris detection.

Sample Station



WARNING

Risk of biohazardous contamination and/or instrument damage. When running samples, it is important to insert the sample tube all the way down into the sample tube holder, until the bottom of the sample tube touches the base of the holder. Failing to do this could cause the sample probe to bend or break on entry. Sample tubes must not exceed 80 mm in height and the outside diameter must not exceed 13 mm.

Figure 1.8 Sample Station

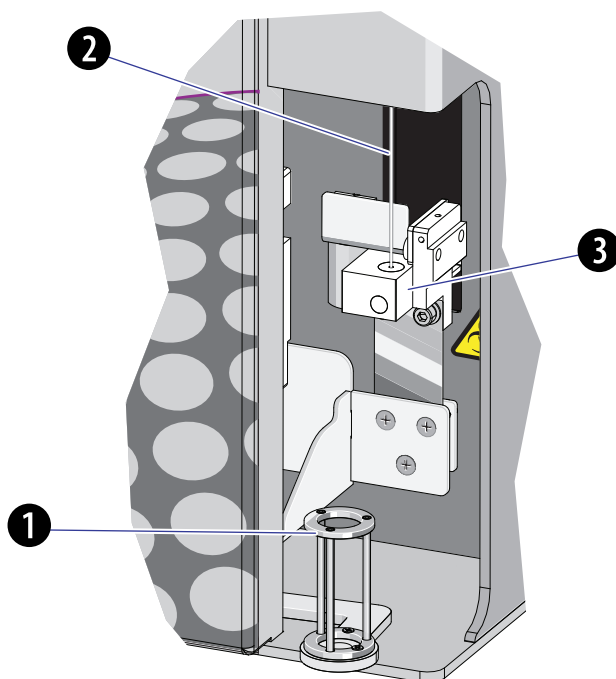

1. **Sample tube holder.** Supports sample tubes for testing, such as 12 x 75 mm, 1.5-mL, and 2-mL microtubes.
2. **Sample probe.** Draws and transfers samples into the flow cell.
3. **Wash station and mixer.** During the sampling process, samples are automatically shaken and mixed for a default time of 1 second. The sample probe is automatically cleaned when the instrument performs a backflush.

Sample Tube Holder Positions

Three of the sample tube holder positions are shown in [Figure 1.9](#): sample loading position (1), standby position (2), and sample acquisition position (3). You can only distinguish the mixing position from the sample acquisition position if you are looking directly at the sample tube holder.

while the Cytometer is processing a sample. The mixing position is about 6 mm lower than the sample acquisition position.

Figure 1.9 Sample Tube Holder Positions

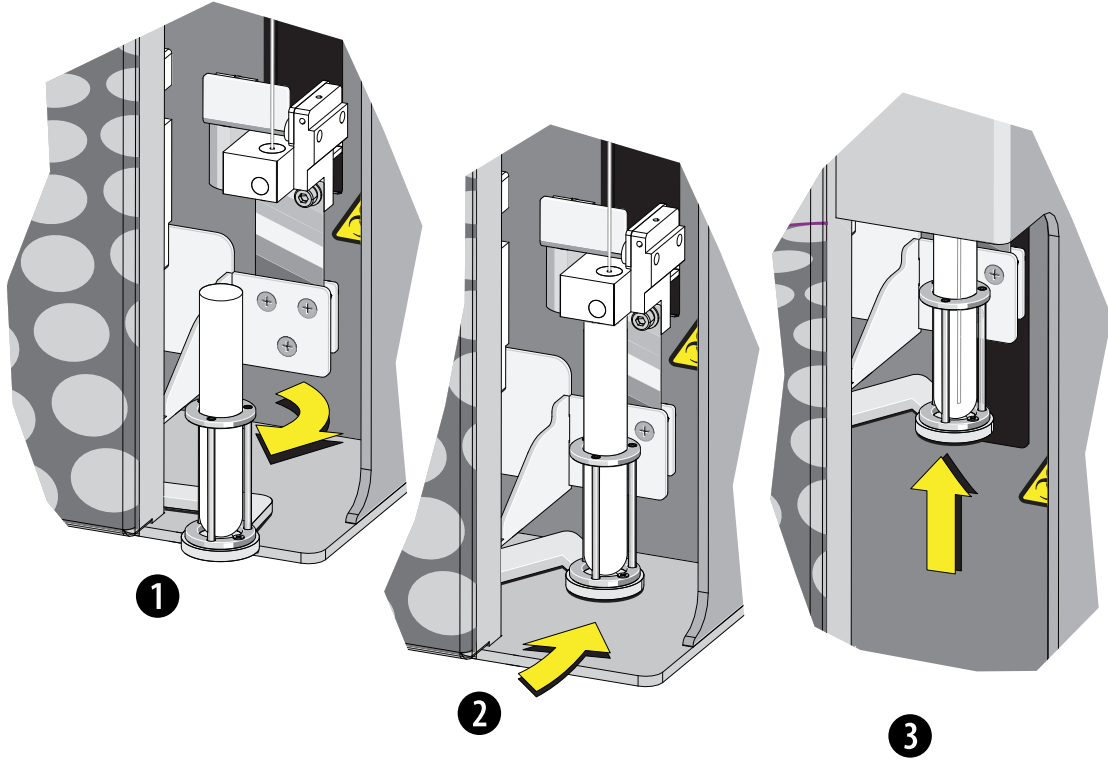
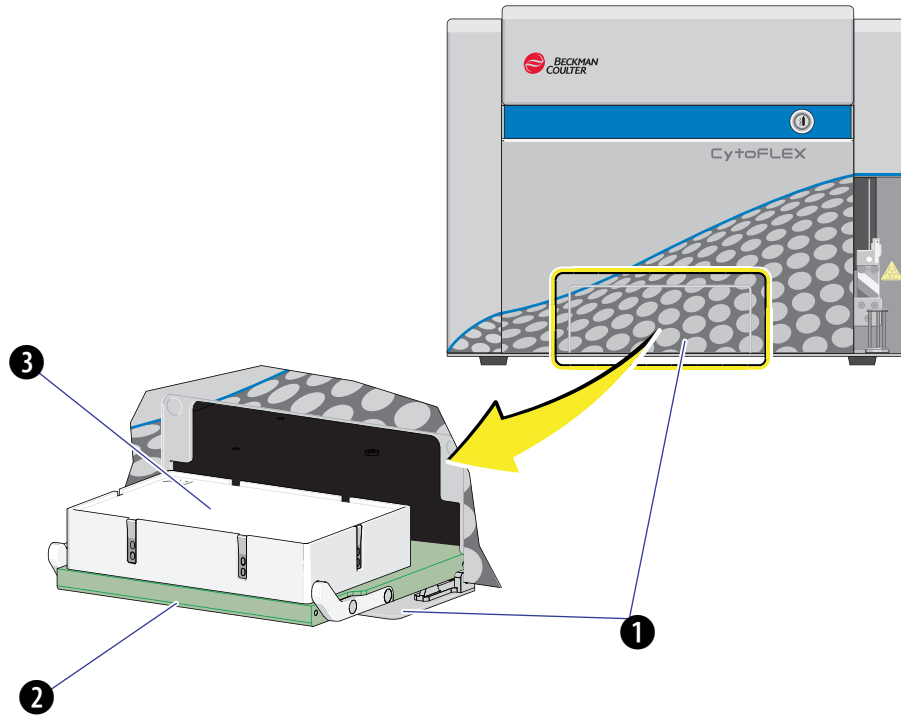

Plate Loader Components

Figure 1.10 Plate Loader



1. Plate loader door
2. Plate holder stage
3. Plate holder (removable)

Figure 1.11 Plate Loader (Front Cover Removed)

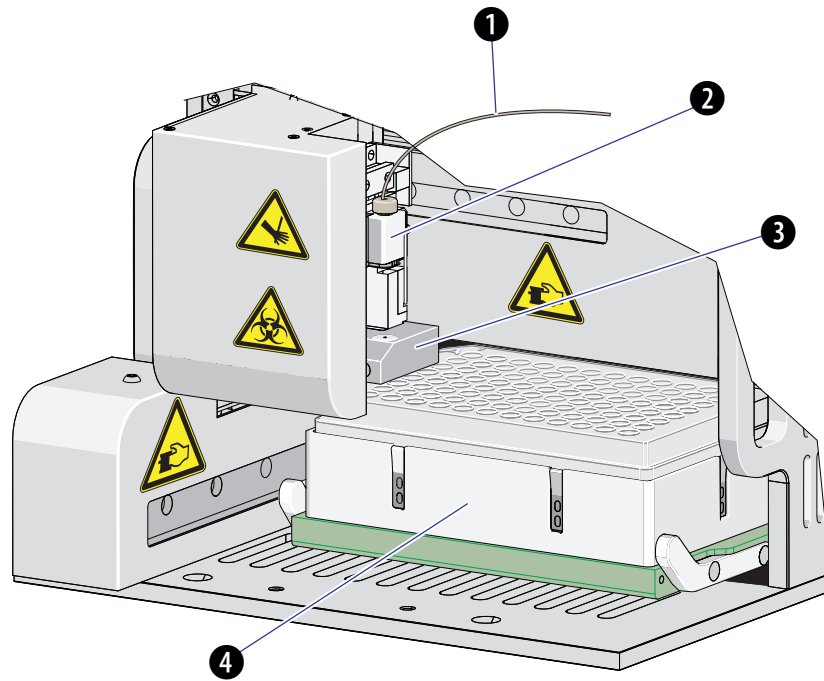

1. Plate loader PEEK tubing
2. Plate loader sample probe assembly
3. Plate loader wash station
4. Plate holder

Plate Holder Components

Figure 1.12 Plate Holder (Top View on Left; Bottom View on Right)

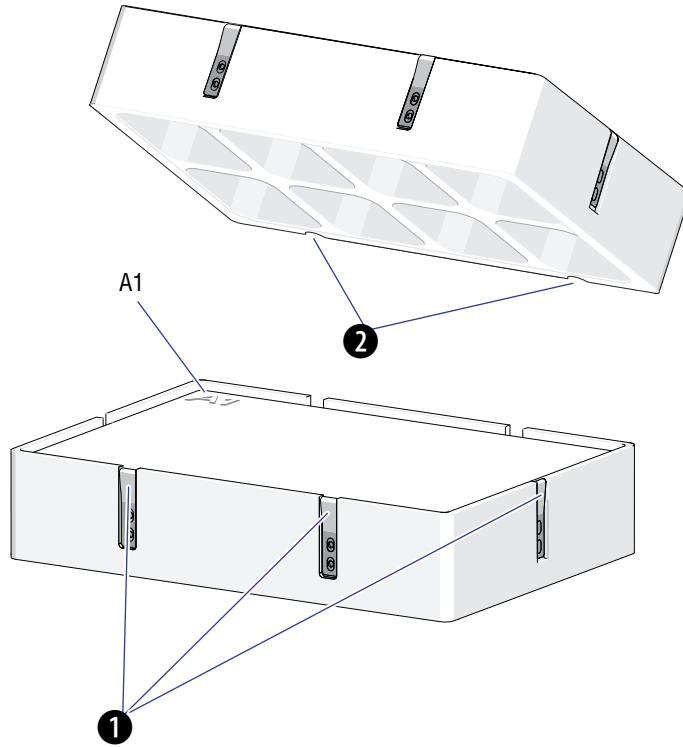

1. Spring leaves to hold plate
2. Plate holder notches

NOTE The Plate holder is removable and replaceable. Refer to [Replacing the Plate Holder \[With Plate Loader\]](#) in [CHAPTER 11, Replacement/Adjustment Procedures](#).

Figure 1.13 Plate Holder Stage

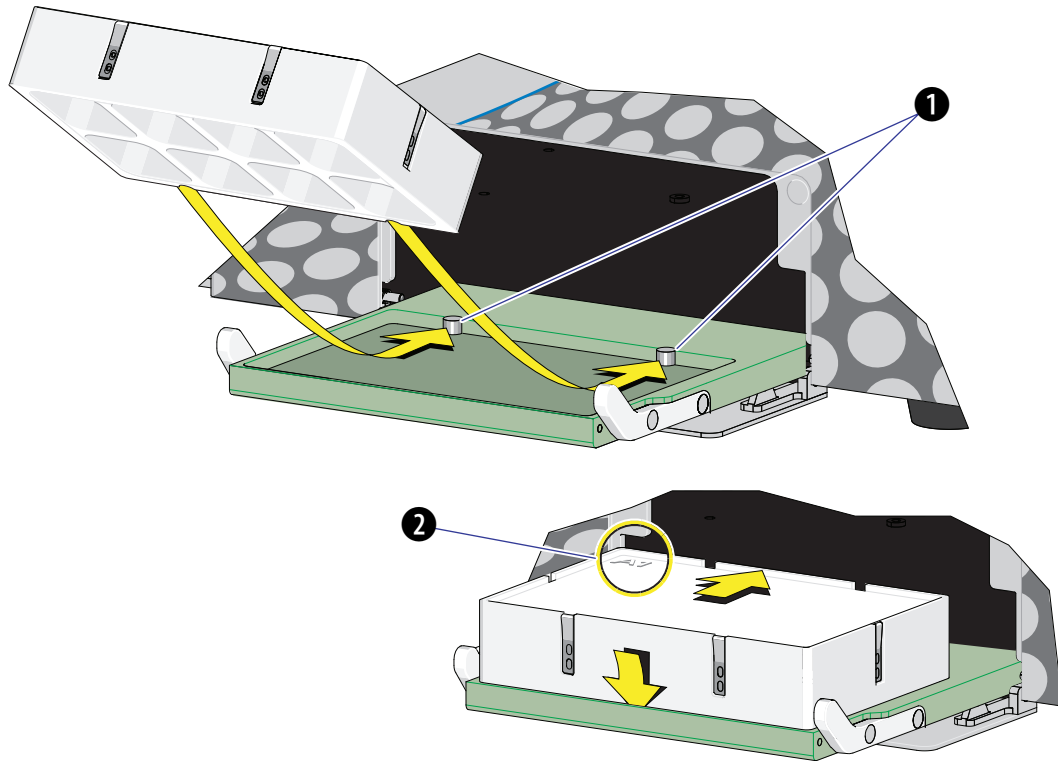

- 1. Pins
- 2. Position A1

System Configuration

CAUTION

Risk of data loss and/or instrument damage. Never shut off the power or disconnect a data cable while the Cytometer is in the process of performing a task. This could cause data loss or damage to the system.

Figure 1.14 System Connections

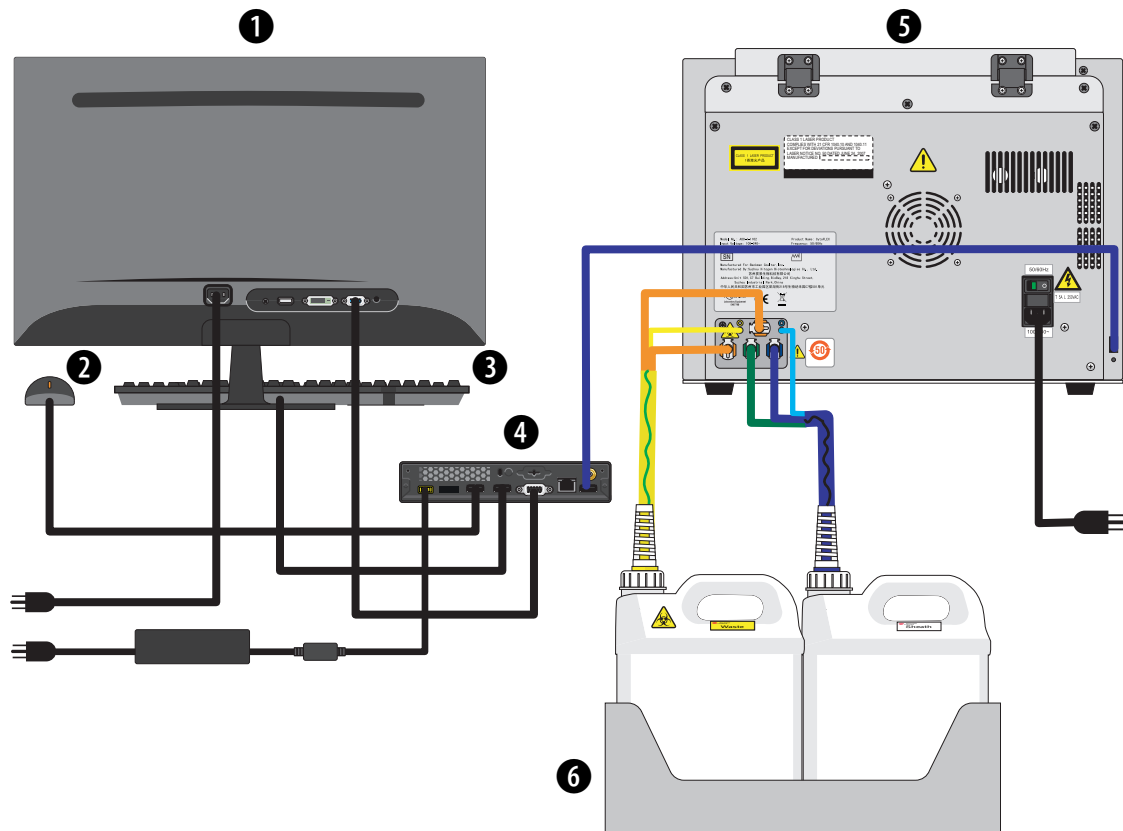

- | | |
|-------------|---------------------------|
| 1. Monitor | 4. Computer |
| 2. Mouse | 5. Cytometer |
| 3. Keyboard | 6. Fluid Container holder |

Figure 1.15 Back Cover Connections

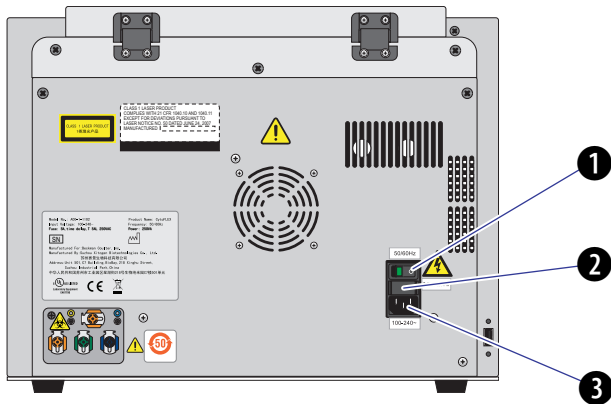

1. **Power switch.** Turns Cytometer on and off. An indicator light glows when the power is on.
2. **Fuse.** Protects the internal system from damage by high electrical current.
3. **Power line socket.** Supplies the power to the Cytometer.

Figure 1.16 Front of Cytometer

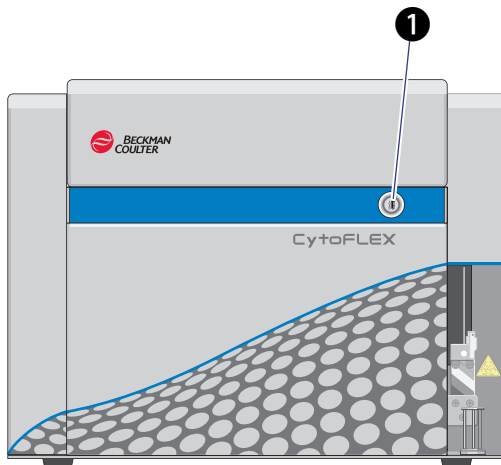

1. **Load button.** In addition to the software controls, this button can be used for automatic sample loading and data recording.

NOTE This function is not available in the Plate Load sample injection mode.

Consumables and Supplies

Reagents

The following reagents are available for the CytoFLEX instrument:

CytoFLEX Daily QC Fluorospheres

CytoFLEX Daily QC Fluorospheres is a suspension of fluorescent microspheres which may be used for daily verification of the CytoFLEX flow cytometer's optical alignment and fluidics system.

CytoFLEX Sheath Fluid

A nonionic, non-fluorescent, and azide-free sheath fluid for use on Beckman Coulter CytoFLEX flow cytometers.

Contrad® 70 Reagent

Diluted 1:1 with DI water for use in the Deep Clean solution bottle.

FlowClean

For use as a cleaning agent for flow cytometer components that come in contact with blood samples.

Material Safety Data Sheets (SDS/MSDS)

To obtain an SDS or MSDS for CytoFLEX reagents used on the CytoFLEX system:

- On the Internet, go to www.beckmancoulter.com:
 1. Select **Safety Data Sheets (SDS/MSDS)** from the Support menu.
 2. Follow the instructions on the screen.
 3. Contact your Beckman Coulter Representative if you have difficulty locating the information.
- If you do not have Internet access contact your Beckman Coulter Representative.

Ordering Information

Your instrument may be upgraded to a more highly configured model. The cost to upgrade depends on the type of configuration needed. For information on specific upgrades, replacement parts, or supplies, visit the Beckman Coulter website at any time: www.beckmancoulter.com. Otherwise, contact your Beckman Coulter Representative.

Instrument Specifications

Dimensions

Dimensions		
Instrument dimensions (Length x Width x Height)	Cytometer [With or Without Plate Loader]	42.5 cm x 42.5 cm x 34 cm
	Fluid Containers and Fluid Container holder	14 cm x 35.6 cm x 35.6 cm
Weight	Cytometer [Without Plate Loader]	23.4 kg
	Cytometer [With Plate Loader]	28 kg

Installation Category

Installation Category 2

Pollution Degree

Pollution Degree 2

Acoustic Noise Level

Measure Level: <65 dBA

Electrical Ratings

Voltage: 100-240 VAC, 50/60 Hz, 250 VA

Cytometer

Optics	
Excitation Optics	The CytoFLEX system can be configured with up to three spatially-separated lasers. The optical system is alignment free. The laser delays are automatically adjusted by the daily QC system, if required. No user intervention is required to ensure optimum system performance.
Emission Optics	Patent-pending alignment-free integrated optics quartz flow cell design with >1.3 NA. Flow Cell dimensions: 420- μ m x 180- μ m internal diameter.

Optics		
Laser devices	Standard wavelengths	<p>Blue laser</p> <ul style="list-style-type: none"> Wavelength: 488-nm, 50 mW Beam spot size: 5 µm x 80 µm <p>Red laser</p> <ul style="list-style-type: none"> Wavelength: 638-nm, 50 mW Beam spot size: 5 µm x 80 µm <p>Violet laser</p> <ul style="list-style-type: none"> Wavelength: 405-nm laser device, 80 mW Beam spot size: 5 µm x 80 µm
Forward scatter detection	Si-photodiode with built-in 488/8 band-pass filter:	
Fluorescence and side scatter detection	Fluorescence and side scatter light collected by the objective lens is delivered by fiber optics to a patent-pending design with high performance, solid-state, high efficiency, low-noise detector arrays. Reflective optics with a single transmission band-pass filter in front of each detector.	
Violet side scatter configuration (VSSC)	The CytoFLEX system offers the ability to configure the violet laser detector to collect side scatter to better resolve nano particles from noise.	

Fluidics System		
Sample loading speed	Defaults	Slow 10 µL/min Medium 30 µL/min Fast 60 µL/min
Fluid capacity	Standard 4-L sheath fluid and waste containers	
Automated maintenance cycles	Startup (initialize), system startup program, sample mix, backflush, prime, Shutdown (Daily Clean), Deep Clean	
Sample input formats	Single Tube Loader format	5 mL (12 x 75 mm) polystyrene and polypropylene sample tubes Microcentrifuge 1.5 mL and 2 mL sample tubes

Fluidics System [With Plate Loader]		
Sample input formats	Plate Loader format	Flat/U/V bottom standard 96-well plate
Dead Volume	96-well flat bottom plate	20 µL
	96-well U bottom plate	10 µL
	96-well V bottom plate	10 µL
Minimum Sample Volume	45 µL/well	
Maximum Sample Volume	250 µL/well	

Electronics	
Signal processing	7 decade data display
Digital sampling rate	25 Mhz
Signal	Pulse area, height for every channel, width for one selectable channel

Data Management		
Software	CytExpert software	
Language	English and Chinese	
FCS format	FCS 3.0	
Minimum Workstation/ computer requirements	Operating system	Windows® 7 Professional 64-bit
	Processor	4th Gen Intel® Core™ i3 (3MB Cache, 2.90 GHz)
	Memory	4 GB RAM
	Storage	256 GB
	Port	1 GB Ethernet port
	USB	2 USB 3.0 ports 4 USB 2.0 ports
Compensation	Full matrix compensation, manual and automatic. Novel Compensation Library for storage of spillover values of dyes to easily determine the correct compensation matrix with new gain settings.	
QC	Auto daily QC routine with Levey-Jennings tracking and logging.	

Performance Characteristics

Performance		
Sensitivity	MESF	FITC: <30 molecules of equivalent soluble fluorochrome (MESF-FITC) PE: <10 molecules of equivalent soluble fluorochrome (MESF-PE)
Fluorescence resolution	rCV <3% The CytoFLEX Flow Cytometer is capable of achieving <3% rCV only with calibration reagents that have the capability to achieve this specification.	
Side scatter resolution	<300 nm	
Violet Side scatter resolution	<200 nm	
Forward and side scatter resolution	Scatter performance is optimized for resolving lymphocytes, monocytes, and granulocytes as well as nanoparticles.	

Performance		
Carryover	Single Tube Loader format	≤1.0%
Signal acquisition speed	30,000 particles/second with 15 parameters	

Performance [With Plate Loader]		
Carryover	Plate Loader format	<0.5%
Throughput [With Plate Loader]	10 second acquisition without mixing or cleaning: <32 min.	
	10 second acquisition with 3 second mixing and 3 second cleaning: < 45 min.	

Reagent Limitations

Only use nonionic strength sheath fluid, like CytoFLEX Sheath Fluid. Do not use sheath fluid containing electrolytes.

Using the CytExpert Software

Overview

The CytExpert software is a full-feature software package that controls the instrument's operation, collection of experimental data, and analysis of the results. This chapter will explain the software's functions and features.

This chapter contains information on:

- [Launching the Software](#)
- [Main Software Screen](#)
- [Graphic and Gating Styles](#)
- [Software Settings](#)

Launching the Software

Select the desktop shortcut  to launch the CytExpert software.

If there is no desktop shortcut, run the “CytExpert.exe” software directly from the software installation directory. The default installation path is C:/Program Files/CytExpert.

Refer to [Opening the Software](#) in [CHAPTER 3, Daily Startup](#), for detailed instructions on opening the software and confirming the connection status.

Main Software Screen

Hover your cursor over any button to display a text pop-up of the button's function.

Start Page

The start page automatically opens after the software has been launched.

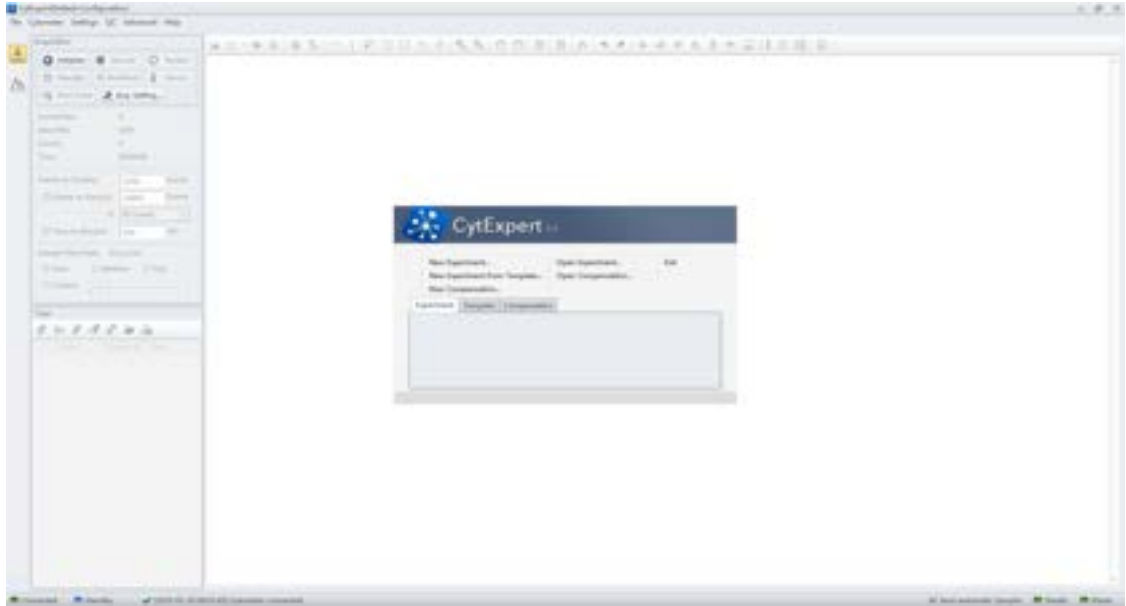

The following operations can be selected from the start page:



- **New Experiment.** For creating a new experiment. The process creates a file with the .xit extension and a folder with the same file name where the raw data (.fcs files) are kept.
- **New Experiment From Template.** For creating an experiment using previously selected elements.
- **New Compensation.** For setting up compensation for an experiment.
- **Open Experiment.** For opening a previously created experiment.
- **Open Compensation.** For opening a previously created compensation experiment.
- **Exit.** For exiting CytExpert.

The Experiment, Template, and Compensation tabs below give you the option of opening one of the 10 most recently opened experiments.

Acquisition Screen

Selecting **New Experiment**, **New Experiment From Template**, or **Open Experiment** automatically opens the Acquisition screen. The Acquisition screen can be accessed by selecting  on the left side of the page.

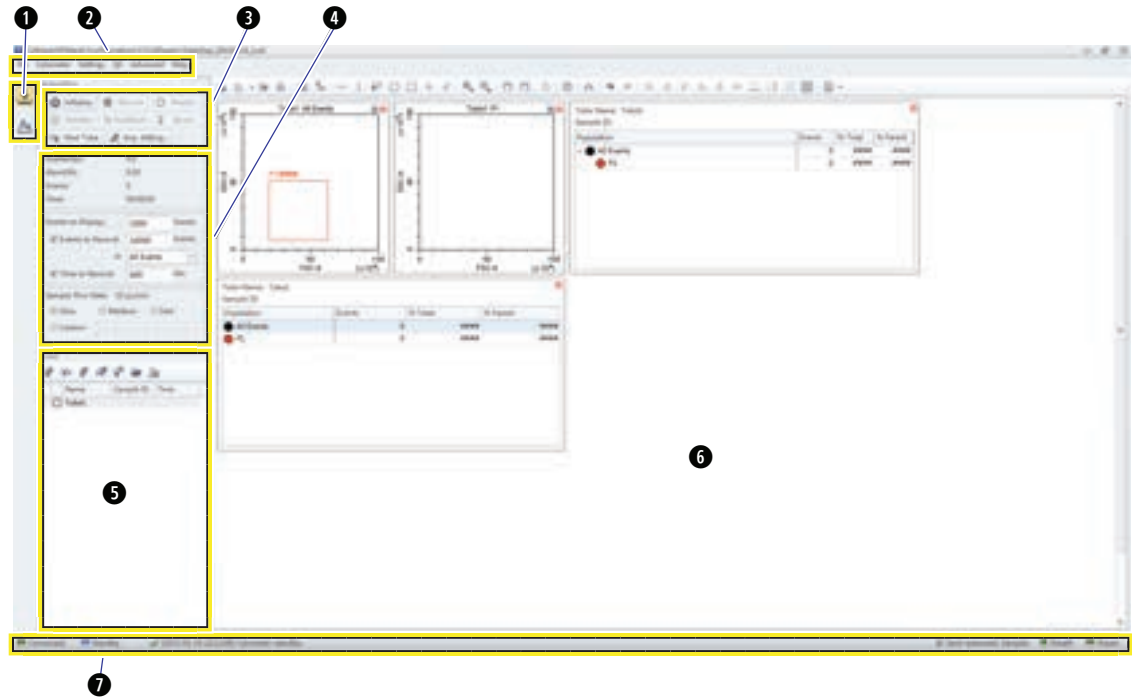

1. **Navigation.** Gives the option of accessing the acquisition screen or analysis screen.
2. **Menu.** Allows you to configure settings for sample acquisition, instrument operation, and software options.
3. **Instrument Operation Controls.** Controls sample loading/unloading and data acquisition and recording.
4. **Collection.** Establishes control over data recording options and displays the acquisition status.
5. **Test tubes.** Allows you to configure and duplicate sample tubes, set display attributes, manage experimental data and compensation.

NOTE The Tube section of the screen can be expanded or retracted by dragging the top border of the Tube section of the screen. Expanding this section covers other elements of the screen, including: Events to Display, Events/Sec, and the Acquisition buttons.

6. **Plot area.** Includes plot and gating controls, as well as an area for drawing plots and generating graphs.
7. **Status bar.** Displays instrument connection status and system information.

Acquisition Screen Navigation

The Acquisition screens have two navigation icons, one for the Acquisition screen and the other for the Analysis screen.



1. **Acquisition screen icon.** Accesses the Acquisition screen.
2. **Analysis screen icon.** Accesses the Analysis screen.

Collection

Standby state



Initialized state



1. **Acquisition control.** Controls sample loading/unloading and data acquisition and recording.
2. **Acquisition status.** Displays such information as the acquisition rate (Events/Sec), cell count, duration, and abort (%).
3. **Acquisition conditions.** Sets the necessary conditions for recording data.
4. **Sample flow rate.** Sets the acquisition rate for data collection.

NOTE High acquisition rate increases the abort rate and measurement CVs.

Collection [With Plate Loader]

Standby state

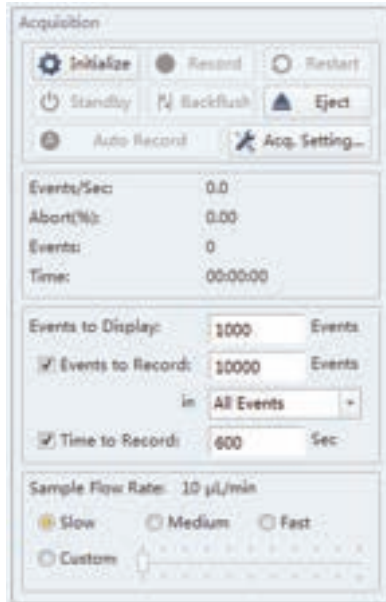

Initialized state

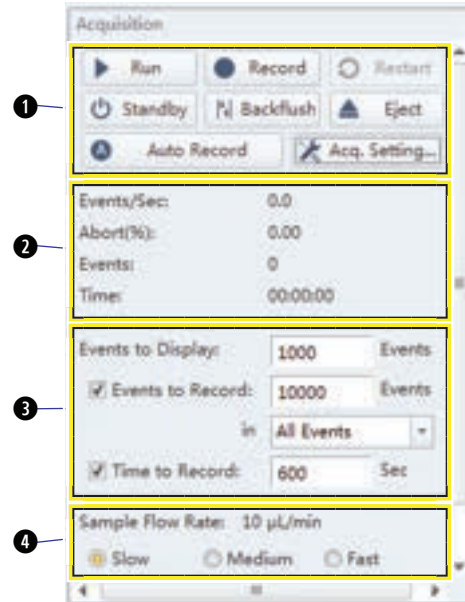



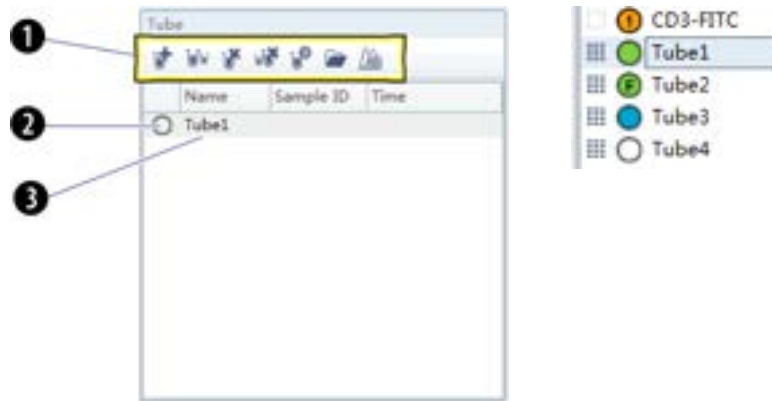

1. **Acquisition control.** Controls sample loading/unloading and data acquisition and recording.
2. **Acquisition status.** Displays such information as the acquisition rate (Events/Sec), cell count, duration, and abort (%).
3. **Acquisition conditions.** Sets the necessary conditions for recording data.
4. **Sample flow rate.** Sets the acquisition rate for data collection.

NOTE High acquisition rate increases the abort rate and measurement CVs.

Test Tubes



1. **Test tube management controls.** Manages sample tubes. Used to add, copy, or delete attributes, open the tube property, and open the compensation matrix.
2. **Test tube status indication.** Displays a colored symbol in front of each tube indicating the status of the tube processing.

-  indicates that the tube data was not collected.
-  indicates that the tube data was acquired by selecting **Run** but not saved, and the tube data can be overwritten.
-  indicates that the tube data was saved by selecting **Record** and that this data cannot be overwritten.
-  indicates imported FCS data.

NOTE  to the left of the test tube status indication symbol indicates that the sample has been compensated.

-  indicates the data file is missing or there is an error in the data file.

3. **Test tube list.** Displays the sample tubes used in the experiment. Right-click a tube in the list to perform additional operations.

NOTE In the Plate Loader Sample Injection mode the well number displays at the end of the tube name.

Plot area

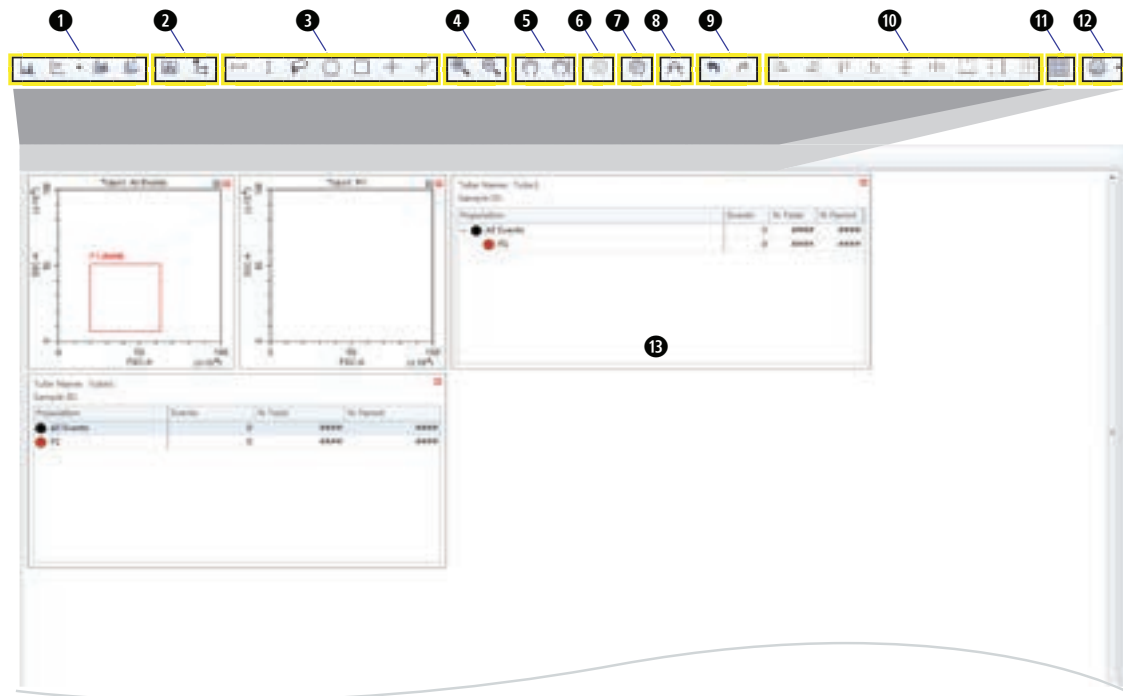

1. **Plot controls.** For creating single or multiple plots, such as scatter plots, histograms, density plots, pseudocolor plots, and contour plots.
2. **Statistics and hierarchy controls.** For creating statistical and hierarchical charts.
3. **Graphical gating controls.** For graphical gating of plots that have already been drawn.
4. **Zoom controls.** For zooming in and out.
5. **Axis display controls.** For scaling axis ranges in the plots.
6. **Gain adjustment control.** For increasing and lowering gain adjustments on the plots.
NOTE The gain adjustment control only works when a sample is running.
7. **Adjust compensation control.** For adjusting compensation of either of the parameters on a 2-D histogram.
8. **Threshold control.** For setting the minimum particle size limit or fluorescence intensity that acquisition will allow.
9. **Undo and redo controls.** For undoing or redoing an action in the drawing area.
10. **Display controls.** For controlling how plots and tables are aligned and arranged.
11. **Rearrange.** For restoring the plots to the default positions.
12. **Printing controls.** For printing and previewing the plot area.
13. **Plot area.** For drawing plots and displaying statistics and hierarchy tables.

Status Bar



1. **Communication connection status.** Displays whether the Cytometer and the Workstation are connected.
2. **Instrument status information.** Displays the status of the Cytometer.
3. **Sampler status.** Displays the sample injection mode state. There are two sample injection modes: Semi-automatic sample injection mode and manual sample injection mode.

NOTE CytoFLEX Cytometers equipped with a plate loader have three sample injection modes: Semi-automatic sample injection mode, manual sample injection mode, and plate loader sample injection mode.

4. **Fluid status information.** Displays the liquid level of the Fluid Containers.

Analysis Screen

The Analysis screen is similar to the Acquisition screen, without the acquisition control modules.

Semi-Automatic Sample Injection Mode Shown

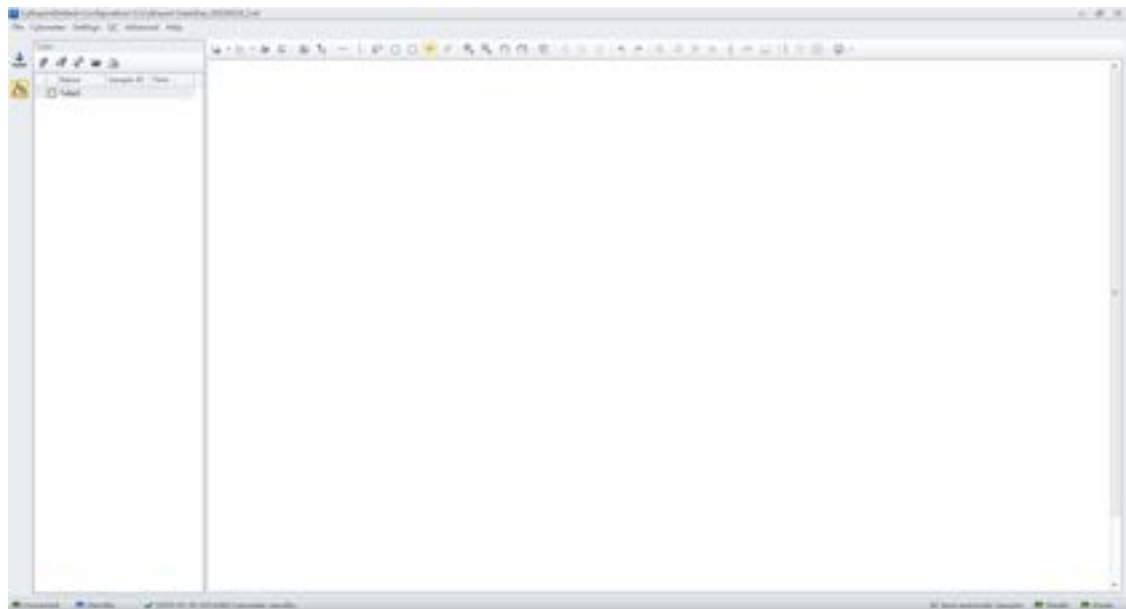

The test tube management module cannot add new sample tubes.

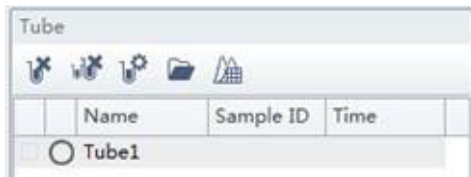

Drawing controls (see [Figure 2.1](#)) include the multi-data histograms and graphical display data controls.

Figure 2.1 Drawing Controls Toolbar (Top of Screen)

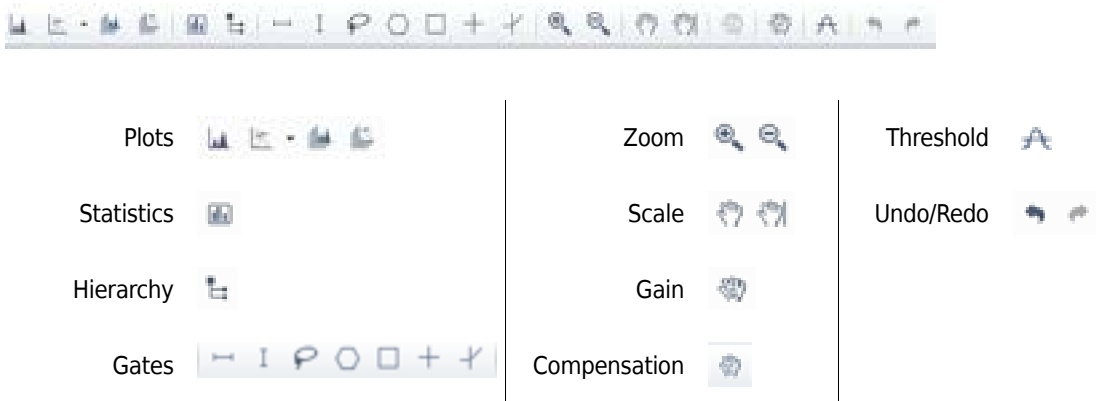

Compensation Experiment Screen

The Compensation Experiment screen appears when you open or create a new compensation experiment.

Semi-Automatic Sample Injection Mode Shown

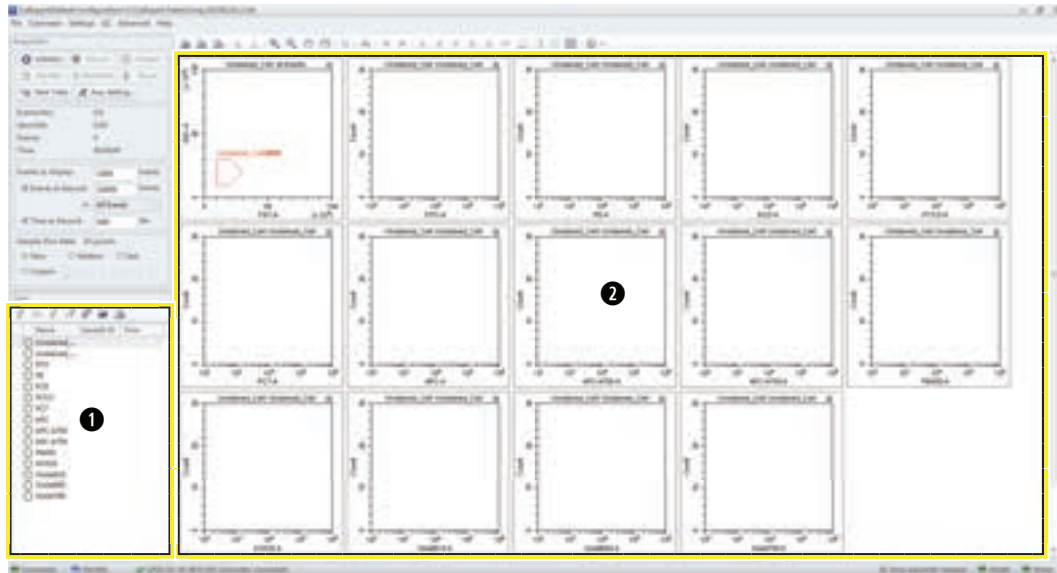

1. **Test tube management.** Displays sample tubes required for the compensation experiment.
2. **Plot area.** Displays compensation plots and gating.

The test tube management section of the screen can import saved data (.fcs) files for computational purposes.

Compensation Controls



The control area includes the compensation controls, coordinate axis display controls, gain adjustment controls, and the undo and redo controls. The compensation controls give you the option of calculating the compensation value, displaying the compensation matrix, or changing the compensation parameters.

QC Experiment Screen

The Quality Control (QC) Experiment screen appears when you access a QC experiment.

QC Settings Screen

Before starting the QC routine, a Settings screen appears.

Semi-Automatic Sample Injection Mode Shown

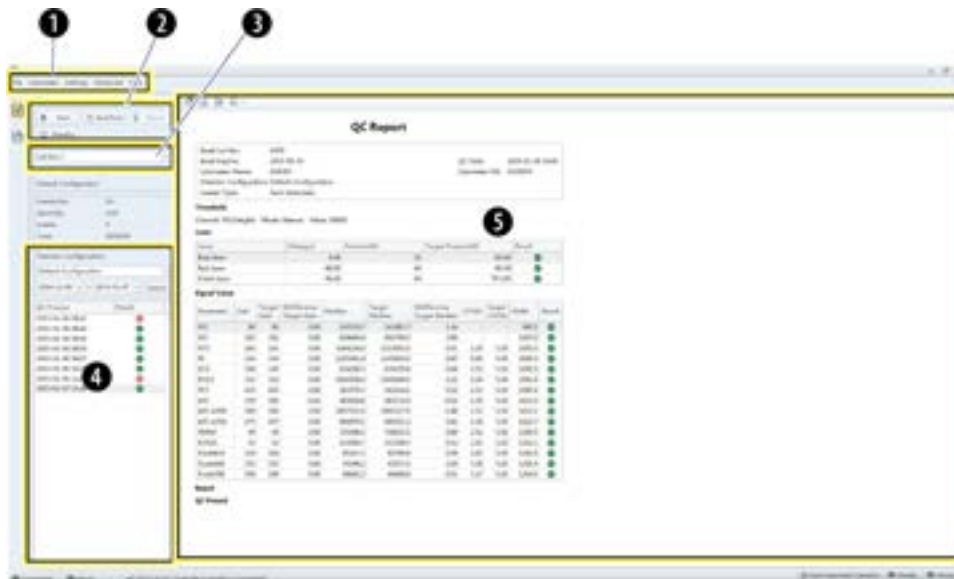

1. **Menu.** Allows you to configure settings related to QC experiments.
2. **Acquisition control.** Controls sample loading/unloading and data recording.
3. **Lot selection.** Allows you to select the correct lot number of the QC reagent.
4. **QC results list area.** Displays the time and results of completed QC runs.
5. **QC reports area.** Displays detailed reports for the selected QC experiment.

QC Experiment Screen

When acquiring QC samples, the software opens the QC screen.

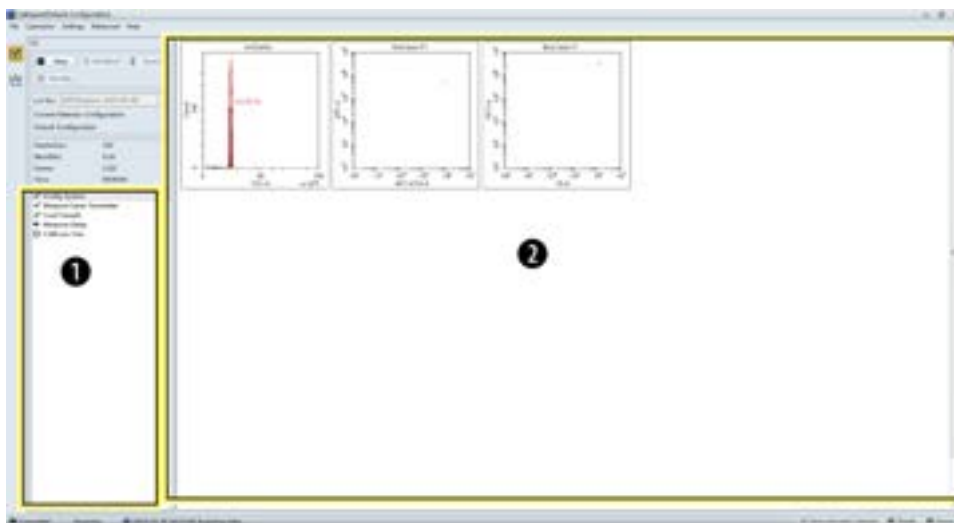

1. **QC experiment progress indicator.** Displays the QC stage.
2. **Plot area.** Displays the QC plots.

QC Screen Navigation

The Analysis screens have two navigation icons, one for the QC screen and the other for the Levey Jennings (LJ) plots.

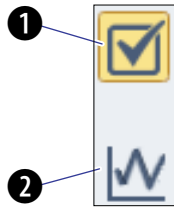

1. **QC screen icon.** Accesses the QC screen.
2. **LJ screen icon.** Accesses the Levey Jennings (LJ) screen.

Software Menu

The CytExpert software contains the following selectable menu items:

Figure 2.2 Software Menu Tree*

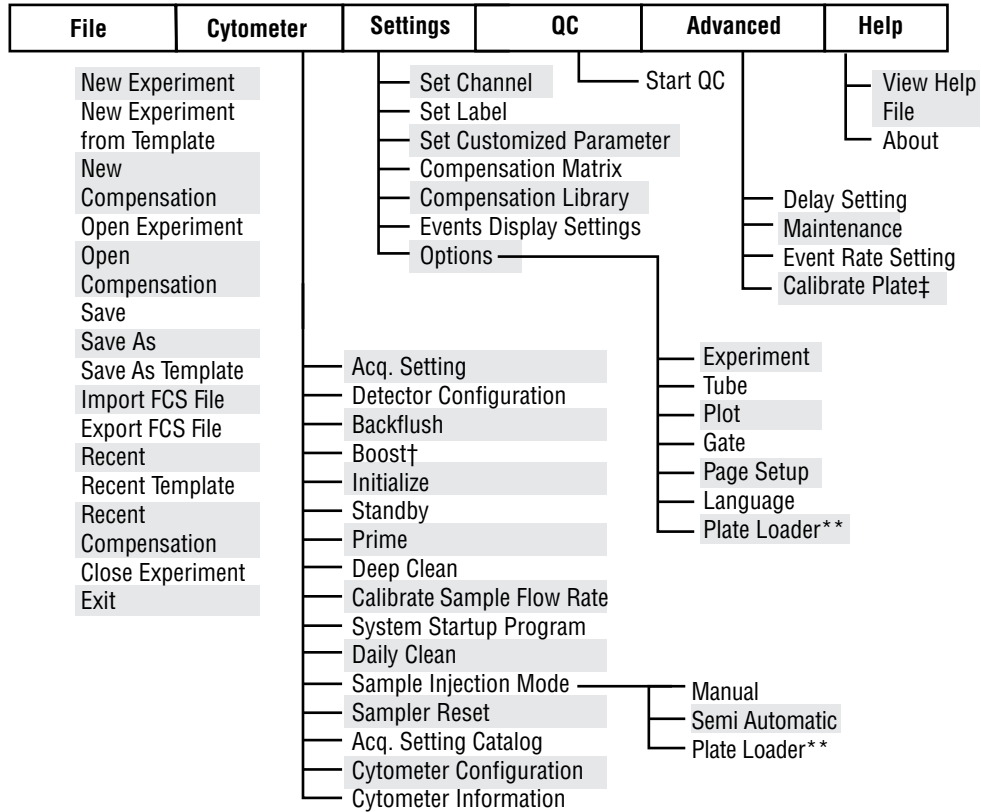

* The menu options for **File**, **Cytometer**, **Settings**, and **QC** change when you select Start QC. Refer to [Figure 2.3](#).

† **Boost** is only active in the Manual Sample Injection mode.

‡ **Calibrate Plate** is only an option if the Plate Loader module is installed and the Plate Loader Sample Injection mode is selected.

** **Plate Loader** is only an option if the Plate Loader module is installed.

Figure 2.3 QC Software Menu Tree

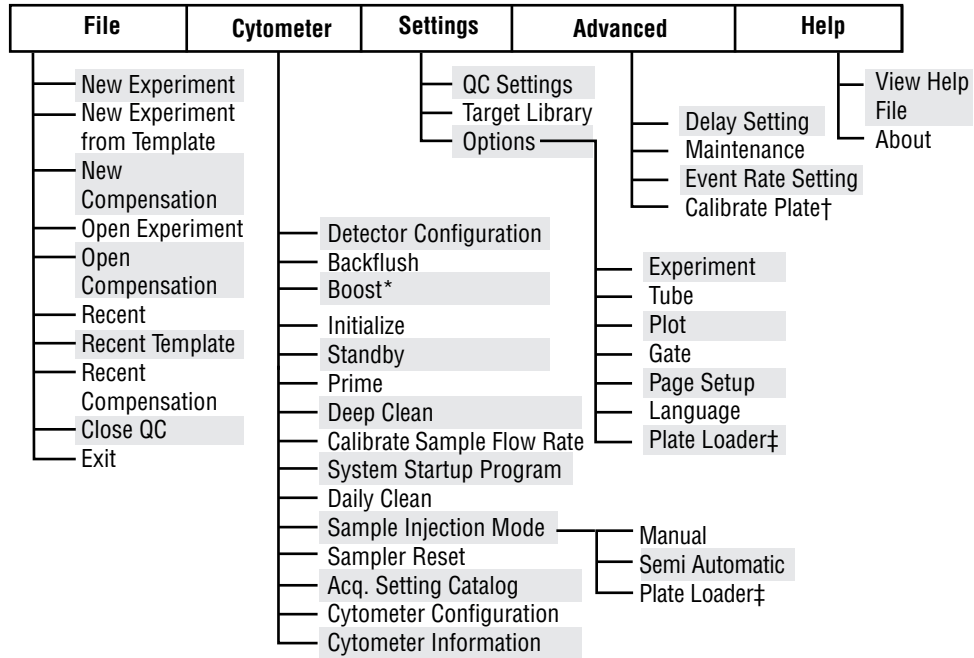

* **Boost** is only active in the Manual Sample Injection mode.

† **Calibrate Plate** is only an option if the Plate Loader module is installed and the Plate Loader Sample Injection mode is selected.

‡ **Plate Loader** is only an option if the Plate Loader module is installed.

Acquisition and Analysis Screen Menu

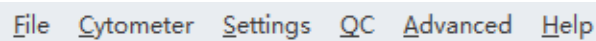

File Menu

For creating new experiments, opening old experiments, saving new experiments and data, and importing/exporting FCS data files.

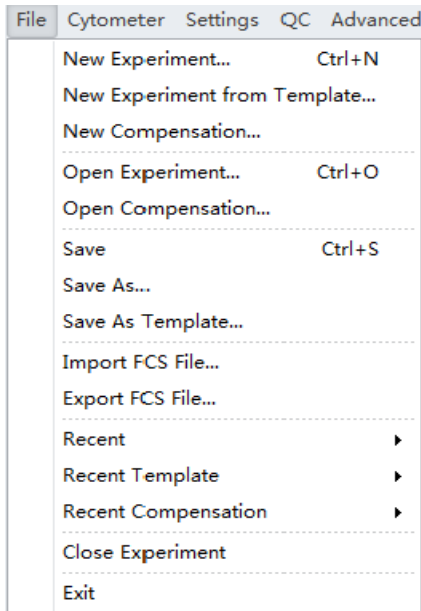

Cytometer Menu

For configuring Cytometer settings and controlling Cytometer functions. Depending on the Cytometer state, certain functions may not be available.

Standby state

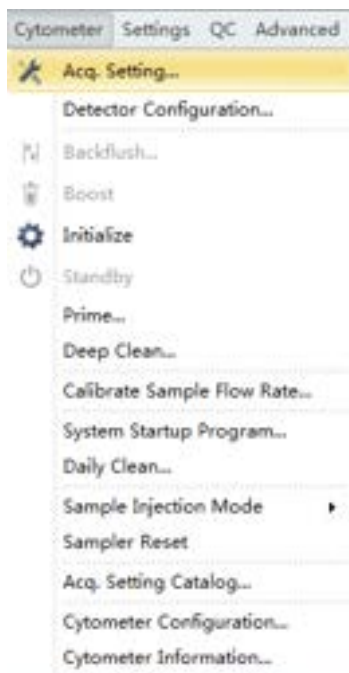

Initialized state

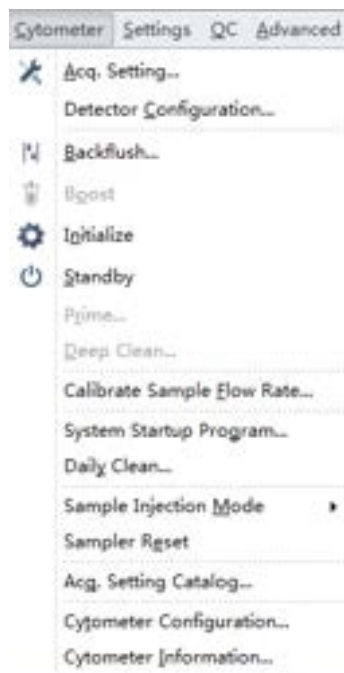

Setting Menu

Used to select and/or change software options and settings.

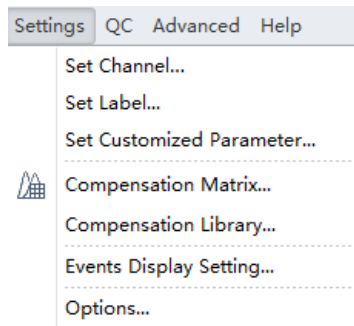

QC Menu

Select **Start QC** from the QC menu to start the QC routine.

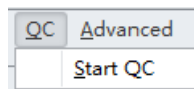

Advanced Menu

Advanced settings for experienced users. Includes laser time delay settings.

Semi-Automatic/Manual Sample Injection Mode

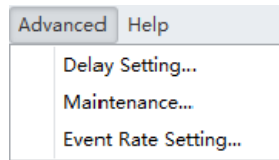
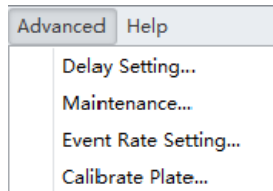
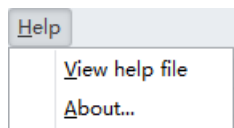

Plate Loader Sample Injection Mode



Help Menu

For displaying software version information and system Instructions for Use.



Graphic and Gating Styles

Plots

The CytExpert software offers a variety of plot formats including:

- Single-parameter plots and histogram overlays
- Dual-parameter plots: dot plots, density plots, pseudocolor plots, contour plots, and dot plot overlays

NOTE Histogram Overlays and Dot Plot Overlays can only be created from multiple samples in the Analysis screen.

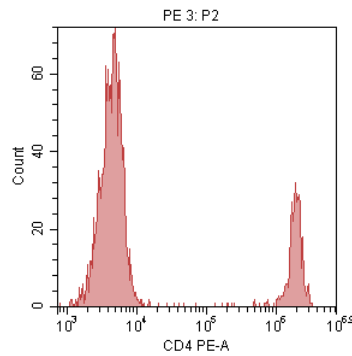

Histogram

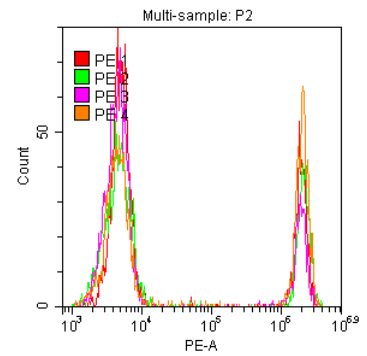

Multi-sample histogram overlays

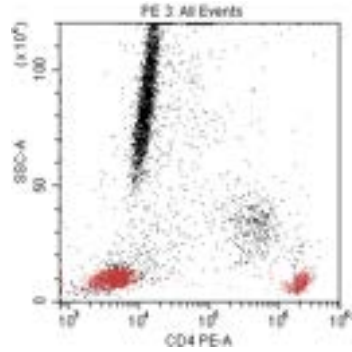
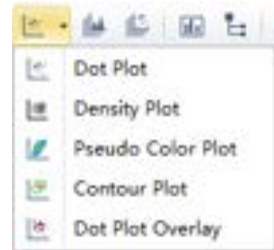

Dot plot

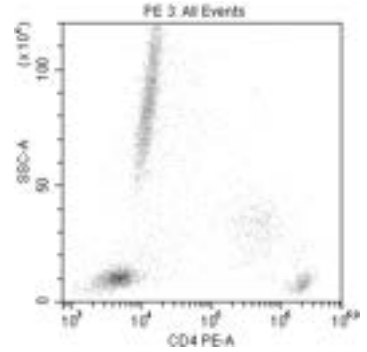

Density plot

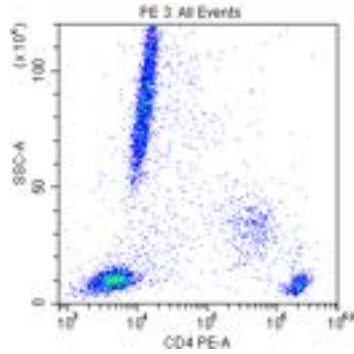

Pseudocolor plot

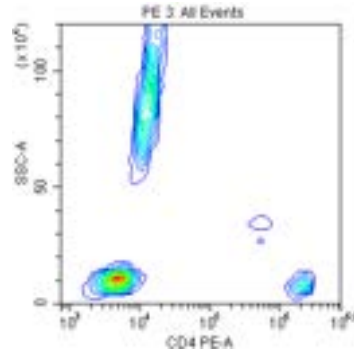

Contour plot

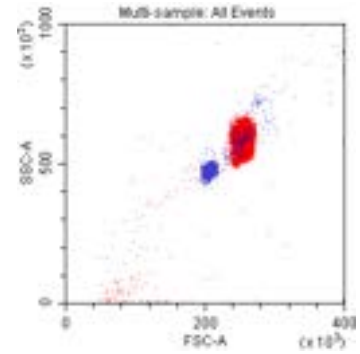

Dot plot overlay

Gates

Various gating choices are available.

The software includes the following gate types:

- For dual-parameter plots: lasso, polygon, rectangle, four-quadrant, and hinged gates
- For single-parameter plots: line-segment and vertical gates

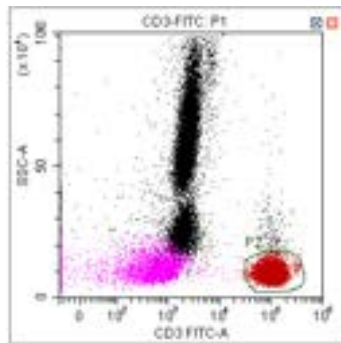

Lasso gate

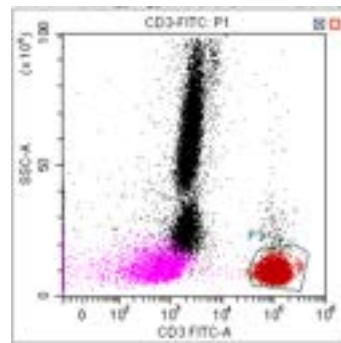

Polygon gate

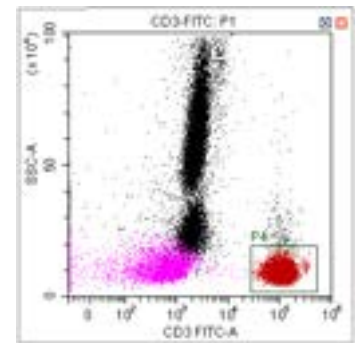

Rectangle gate

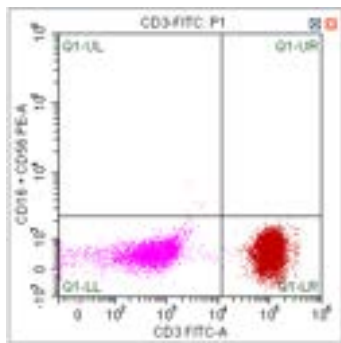

Four-Quadrant gate

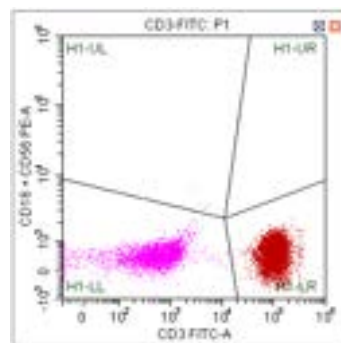

Hinged gate

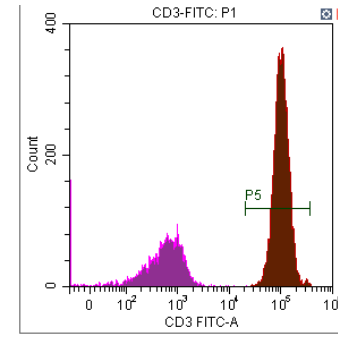

Line Segment gate

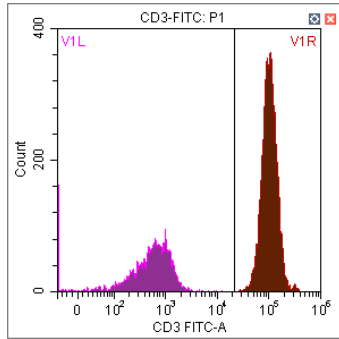

Vertical gate

Software Settings

Select **Options** in the Settings menu to configure the software settings.

In the experiment settings, you can set the experiment's default save path.

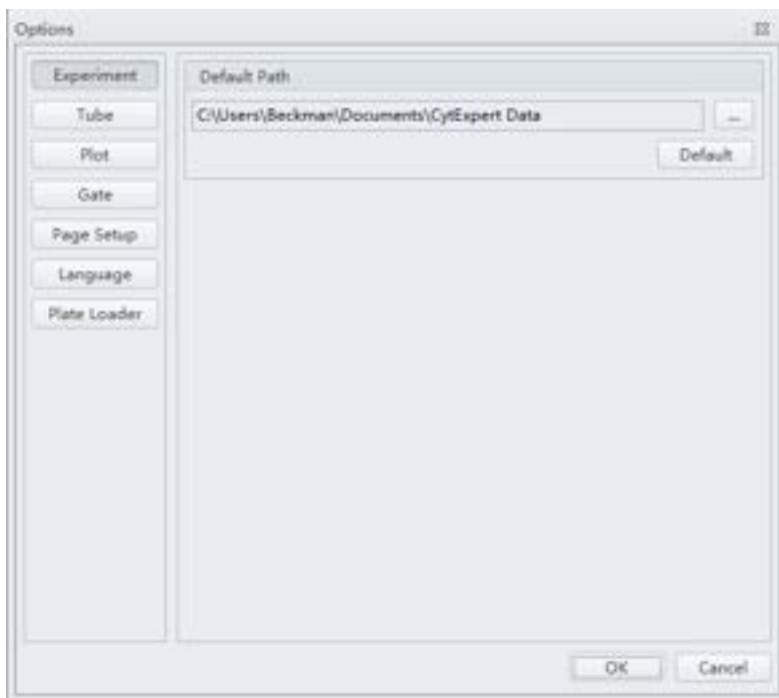

In the tube settings, you can select the columns that display in the test tubes section of the screen.

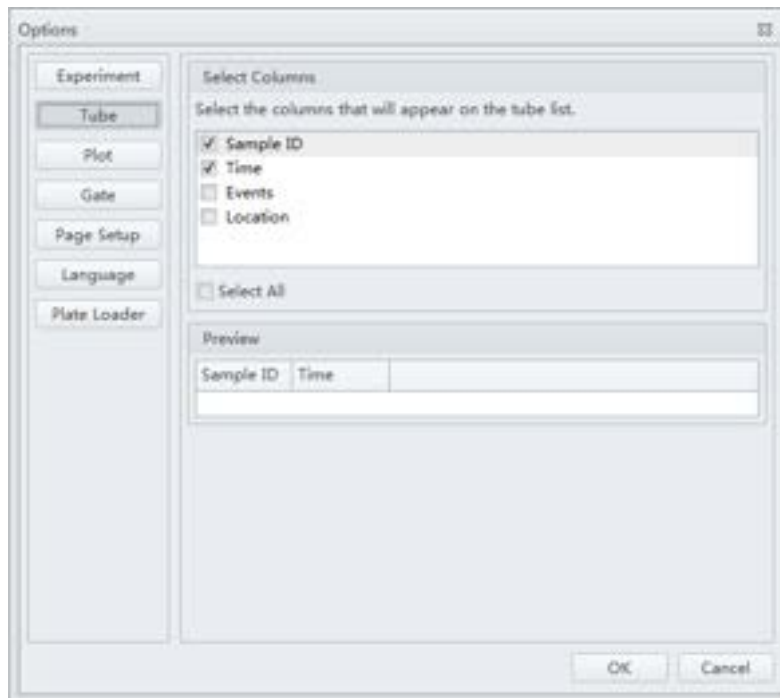

In the plot settings, you can define the background of the graphics display area, configure the histograms, and set the default signal parameters to either the channel's area or the channel's height. The default is area. You can also set the default axis display range.

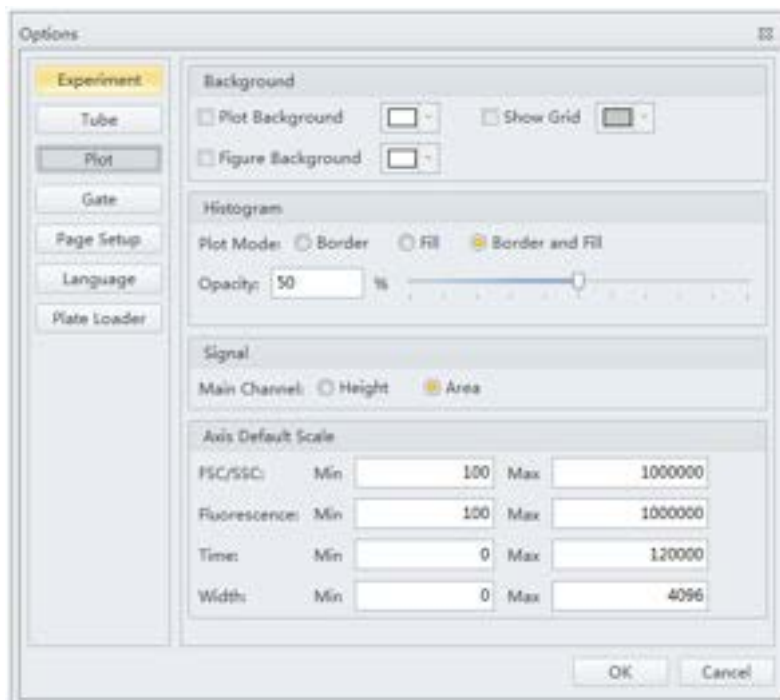

In the Gate settings, you can choose to display population percentage on all plots except overlay.

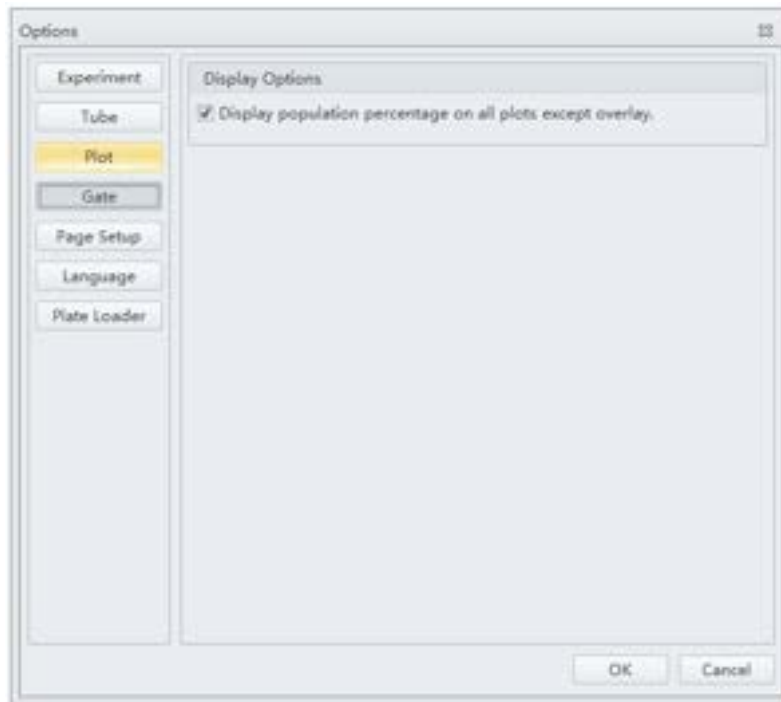

In the Page Setup settings, you can change the page size, orientation, margin size, and display options.

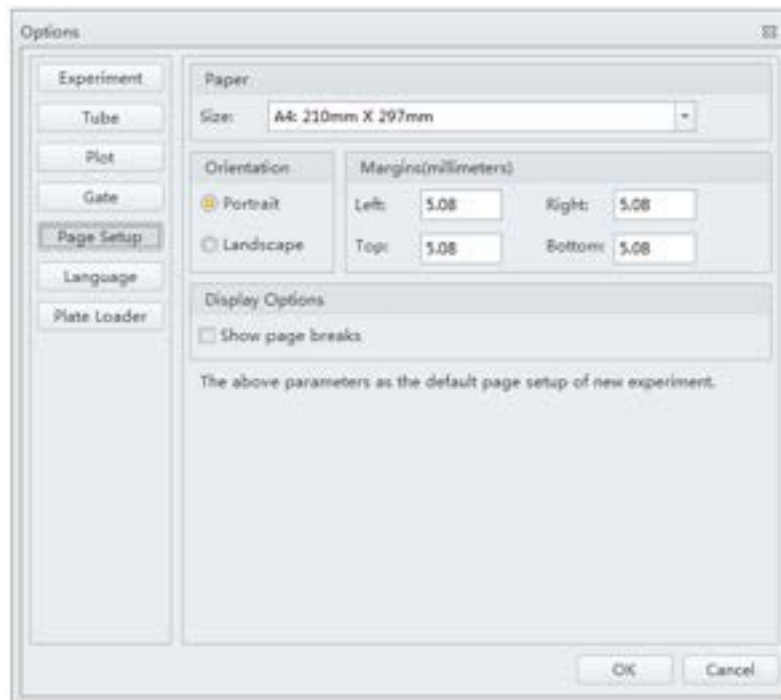

In the language settings, you can select which language to use for the software menus and graphical statistics. The two options currently offered are English and Simplified Chinese.

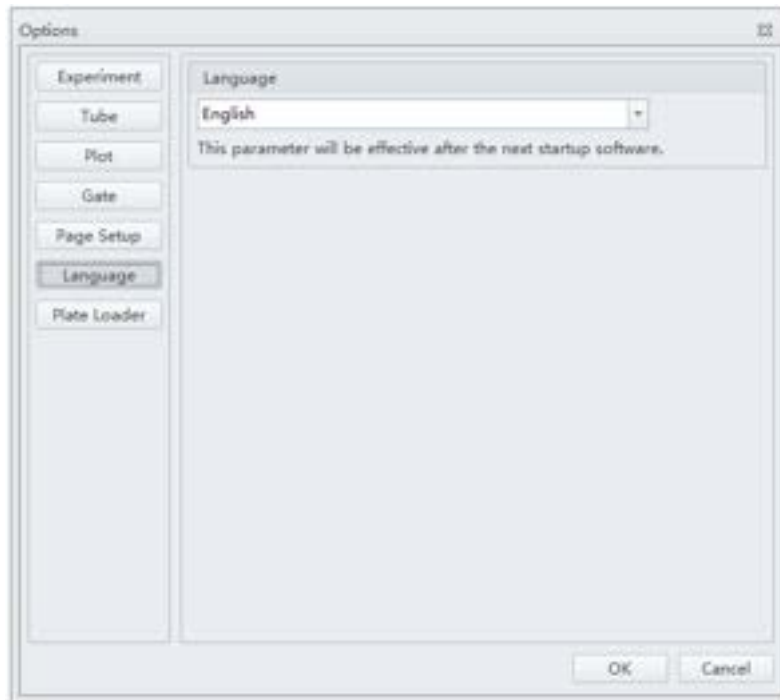

In the plate loader settings, you can select the plate type, sampling sequence, mix, and backflush settings for the plate loader.

NOTE This setting is only available in the Plate Loader sample injection mode.

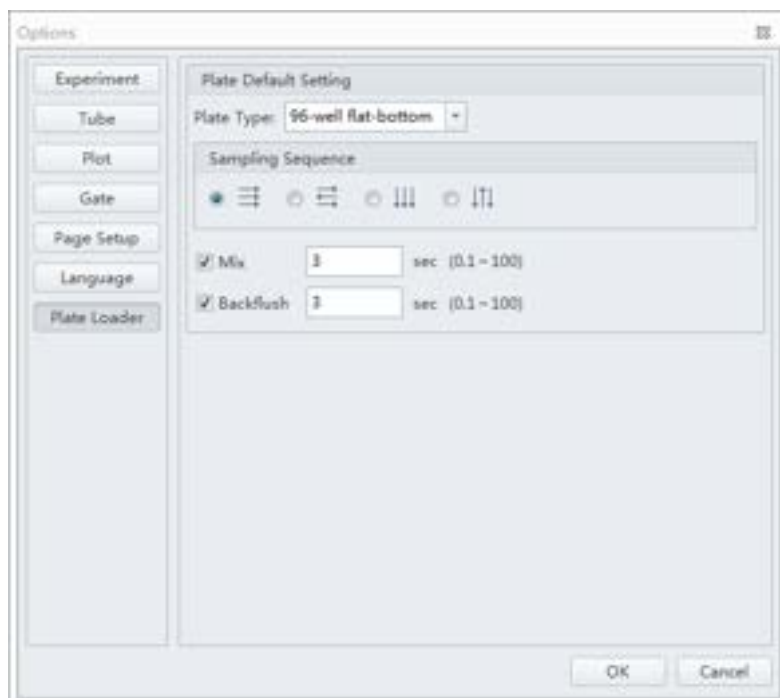

Overview

IMPORTANT Verify that the correct USB configuration key is securely connected to a computer USB port. If the USB configuration key is not connected, the following error message appears: *CytExpert cannot find the license. Please check whether the correct USB configuration key has been plugged in.*

This chapter describes the instrument startup procedure.

Workflow:

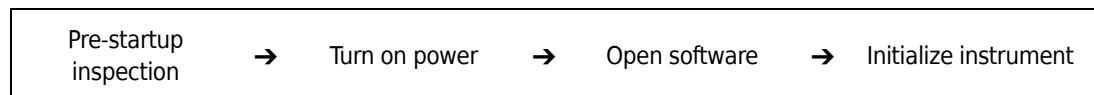

This chapter contains information on:

- [Pre-Startup Inspection](#)
- [Turning On the Instrument](#)
- [Opening the Software](#)
- [Initializing the Instrument](#)

Pre-Startup Inspection

Before using the CytoFLEX flow cytometer, perform the following system checks.

Check Waste and Reagent Levels

CAUTION

Risk of instrument damage. Do not use a saline-based sheath fluid on the CytoFLEX instrument. Saline-based sheath fluid could damage instrument components. Beckman Coulter recommends using CytoFLEX Sheath Fluid or a similar nonionic strength sheath fluid to ensure system performance.

- 1 Examine the sheath fluid and waste containers. Verify that there is sufficient sheath fluid in the sheath fluid container and that the waste container is empty.

NOTE When the sheath fluid container is near empty or the waste container is near full, a warning message is transmitted to the Workstation and audible signals sound as a warning.

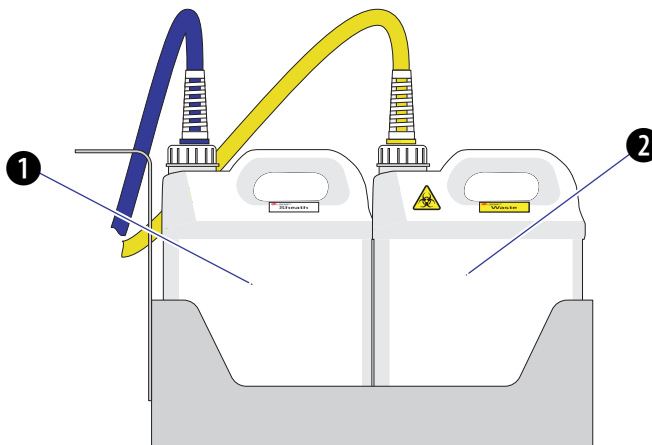

1. Sheath fluid container
2. Waste container

CAUTION

Risk of instrument damage. Remove the sheath fluid container from the Fluid Container holder before filling the sheath fluid container to avoid damage to instrument electronics.

- 2 If necessary, fill the sheath fluid container with CytoFLEX Sheath Fluid or a similar nonionic strength sheath fluid while not exceeding the maximum volume indicated (4 L).

! WARNING

Risk of chemical injury from bleach. To avoid contact with the bleach, use barrier protection, including protective eyewear, gloves, and suitable laboratory attire. Refer to the Safety Data Sheet for details about chemical exposure before using the chemical.

- 3 If necessary, empty all waste liquid from the waste container. If biohazardous samples are used for data collection, add 400 mL of 5 to 6% bleach to the waste container.
- 4 Verify that the Fluid Containers and the Cytometer are on the same level.
- 5 Verify that all flow tubes and sensor cables are properly connected, as shown in the figure:

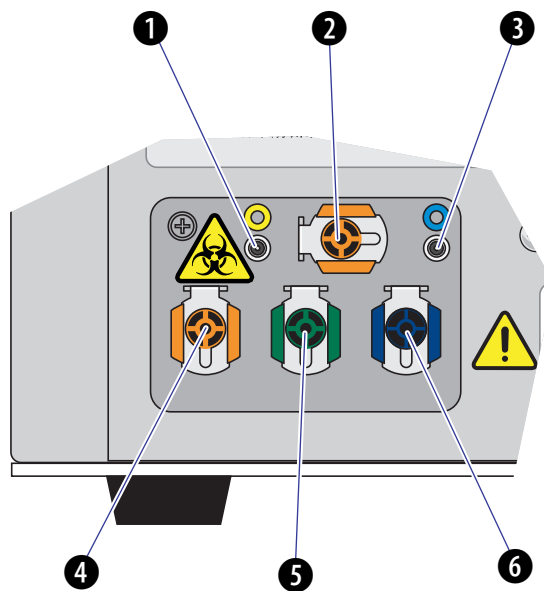

1. **Waste level sensor connector.** Connects to the waste liquid sensor cable.
2. **Flow cell waste out.** Connects to the flow cell waste tubing.
3. **Sheath fluid level sensor connector.** Connects to the sheath fluid sensor cable.
4. **Waste out.** Connects to the waste liquid tubing.
5. **Sheath return.** Connects to the sheath fluid tubing.
6. **Sheath fluid in.** Connects to the sheath fluid tubing.

Power Source Inspection

Check the power cable located below the power switch on the back of the Cytometer, and verify it is securely connected to both the Cytometer and the power source.

Workstation Connections Inspection

Check that the monitor, mouse, keyboard, and the Cytometer are properly connected to the computer. Refer to [Figure 1.14](#).

Turning On the Instrument



1. **If the Cytometer or Workstation fails to start properly, check first to see whether the power cable and connection cables are properly connected.**
2. **Never shut off the power or disconnect a data cable while the Cytometer is performing a task. Doing so can result in data loss or damage to the system.**

1 Turn on the main power switch located on the back cover of the Cytometer.

2 Wait for the Cytometer to finish powering on, then turn on the Workstation.

Opening the Software

- 1 Log in to the Windows operating system and select the CytExpert desktop icon  to open the software.

NOTE The default software shortcut appears on the desktop. If you do not see the icon, the default installation path is under C:/Program Files/CytExpert. Select CytExpert.exe to run the software.

- 2 Confirm that the software and the Cytometer are properly connected.
 - a. Open the software. The Startup screen appears.

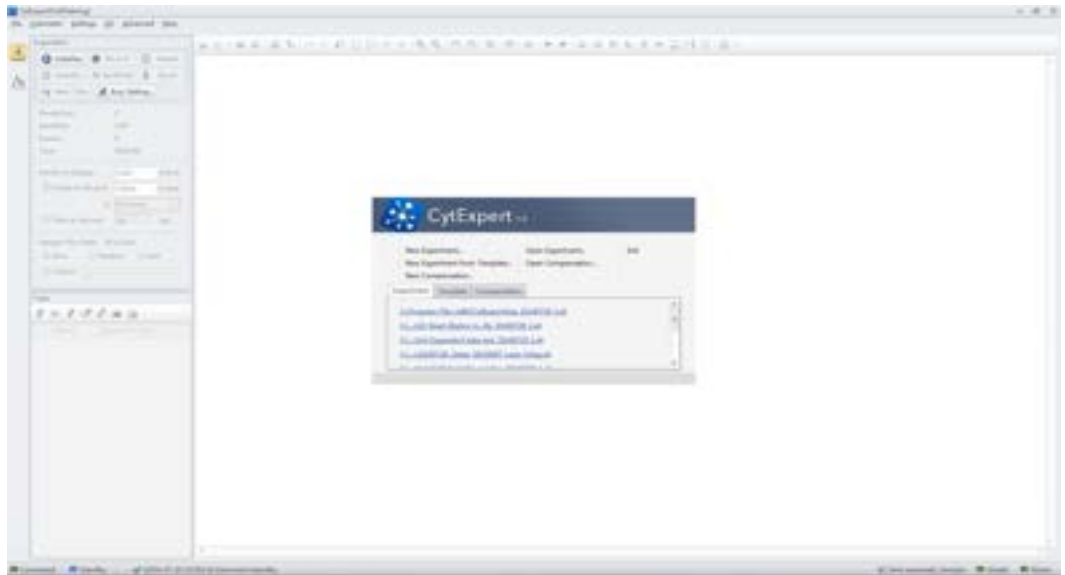

- b. Verify that the connection indicator light in the lower left corner of the software screen is green, and *Connected* is displayed. The left side shows the connection status, the middle shows the instrument status, and the right side shows the status details.



- c. Verify that the *Sheath* and *Waste* flow indicators in the lower right corner of the software screen are green indicating that the fluidics system is normal.

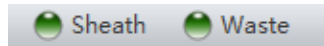

NOTE

- If the connection indicator light is red, it means that there is a faulty connection. Ensure that the instrument is properly turned on and connected. If necessary, restart both the Cytometer and the Workstation.



- After the instrument initializes, a warning beep sounds if there is a problem with the fluidics system. If a flow indicator is red and blinking, it means that the fluidics system requires attention.



- When the waste fluid sensor is disconnected it shows that the waste container is full or nearly full.
- Select the status information in the lower left to open the system log. Send a copy of the system log to your Beckman Coulter Representative for support if a service call is requested.

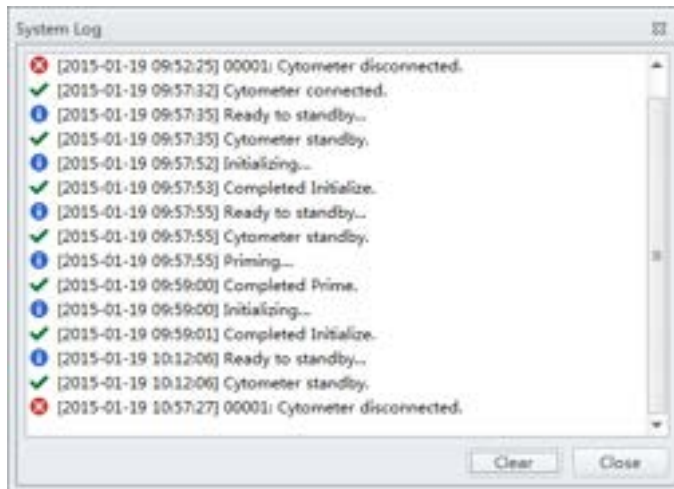

Selecting the Proper Sample Injection Mode

Select **Sample injection Mode** in the Cytometer Menu to change between the Semi-Automatic Injection mode and the Manual Injection mode. The Semi-Automatic Injection mode is recommended under most circumstances. The Manual Injection mode can be used for two purposes:

running 1.5-mL and 2-mL microcentrifuge sample tubes and a backup mode that allows you to continue to collect data if the Semi-Automatic Injection mode is not working correctly.

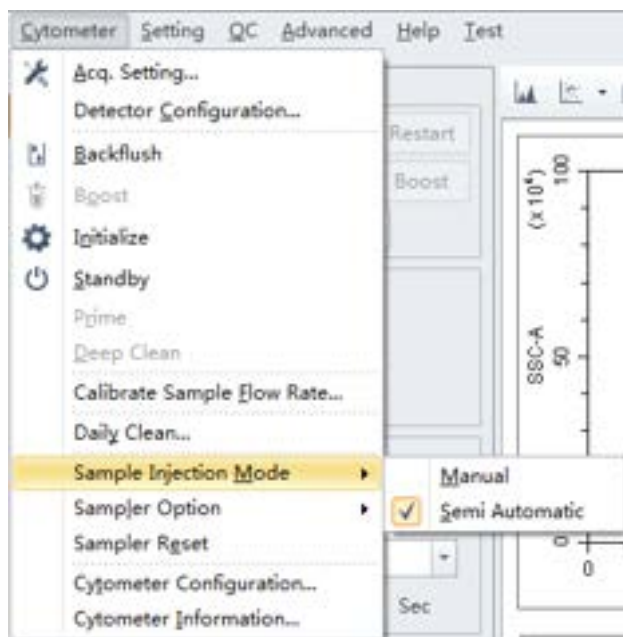

Using Semi-Automatic Injection Mode

- 1 Select **Sample Injection Mode > Semi Automatic** in the Cytometer menu to change the Sample Injection mode selection. The sampler status icon located in the bottom right side of the screen changes to display *Semi-automatic Sampler*.



- 2 Select **Initialize**. The sample tube holder swings out from the standby position to the sample loading position (see [Figure 1.9](#)) so that you can load the sample tube.

NOTE You can also swing out the sample tube holder manually, load the sample tube, then select **Initialize**.

- 3 Select **Run**. The sample tube holder automatically swings back to the standby position and raises the sample tube to the sample acquisition position (see [Figure 1.9](#)), where the instrument mixes the sample and transfers the sample to the flow cell.

At the flow cell, the sample runs at the designated flow rate and the Cytometer begins to acquire data.

NOTE You can also push the load button on the front of the instrument to automatically start the run and record the data.

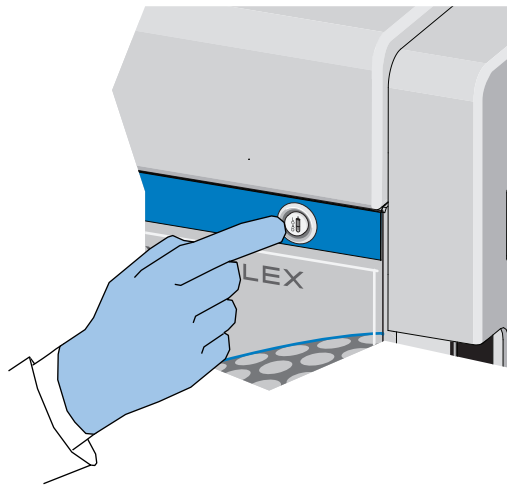

4 When you are satisfied with the appearance of the data, select **Record** to record the data.

5 Wait for the data acquisition to finish or select **Stop**. The sample tube holder automatically lowers the sample tube and moves it to the sample loading position (see [Figure 1.9](#)) and the Cytometer back flushes the sample probe.

 **WARNING**

Risk of biohazardous contamination. When using 1.5-mL and/or 2-mL sample tubes, always cut the cap off and do not exceed 300- μ L sample volume. Running samples with a cap attached to the sample tube or with volumes exceeding 300- μ L can result in sample splashing.

Using the Manual Injection Mode

1 Select **Sample Injection Mode > Manual** in the Cytometer menu to change the Sample Injection mode selection. The sampler status icon located in the bottom right side of the screen changes to display *Manual Sampler*.



2 Manually swing the sample tube holder out from the standby position to the sample loading position (see [Figure 1.9](#)).

-
- 3 Select **Initialize**.

 - 4 Load the sample tube.
NOTE The sample tube holder accommodates 1.5-mL, 2.0-mL, and 12 x 75 mm sample tubes.

 - 5 Manually swing the sample tube holder gently back to the standby position (see [Figure 1.9](#)).

 - 6 Manually raise the sample tube holder gently to the sample acquisition position (see [Figure 1.9](#)) and hold the tube in that position.

 - 7 Select **Boost** to transfer the sample to the flow cell.

 - 8 Select **Run**.
The sample runs at the designated flow rate and the Cytometer begins to acquire data.

 - 9 When you are satisfied with the appearance of the data, select **Record** to record the data.

 - 10 Wait for the data acquisition to finish or select **Stop**. Then, manually lower the sample tube holder and move it to the sample loading position (see [Figure 1.9](#)).

 - 11 Select **Backflush** to clean the probe.
-

Selecting the Plate Loader Sample Injection Mode [With Plate Loader]

Select **Sample injection Mode** in the Cytometer Menu to change between the Semi-Automatic Injection mode, the Manual Injection mode, and the Plate Loader Injection mode. The Plate Loader

Injection mode can be used for running small volumes using the following plates: 96-well flat-bottom, 96-well V-bottom, and 96-well U-bottom.

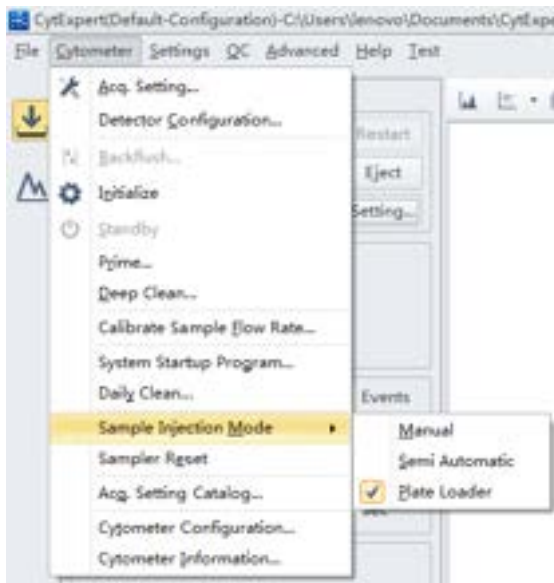

Using Plate Loader Injection Mode

- 1 Select **Sample Injection Mode** > **Plate Loader** in the Cytometer menu to change the Sample Injection mode selection.
- 2 The restart warning prompt appears on screen. Select **OK**.

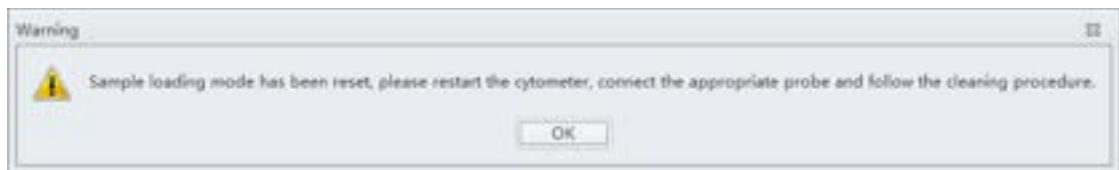

NOTE The restart warning only appears when switching to and from the Plate Loader sample injection mode.

- 3 Turn the Cytometer's main power switch off.
- 4 Remove the single tube sample probe and replace it with the plate loader PEEK tubing. Refer to [Changing the Sample Probe from the Plate Loader to the Single Tube Sample Station \[With Plate Loader\]](#) in CHAPTER 11, Replacement/Adjustment Procedures.

-
- 5 Turn the Cytometer's main power switch on.

The sampler status icon located in the bottom right side of the screen changes to display *Plate Loader*.



-
- 6 Select **Initialize**.

-
- 7 Select **Eject**.

-
- 8 Place the plate flat on the plate holder and ensure that it is secure.

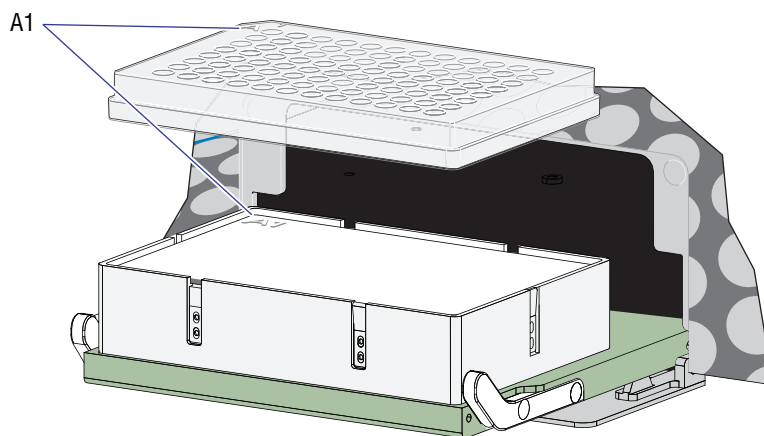

NOTE Ensure that plate well A1 aligns with position A1 on the plate holder.

-
- 9 Select **Load** to load the plate.

-
- 10 Select **Run**. The plate loader automatically loads the plate holder stage and begins to acquire data.

-
- 11 When you are satisfied with the appearance of the data, select **Record** to record the data.

-
- 12 Wait for the data acquisition to finish or select **Stop**. The Cytometer back flushes the sample probe.

13 Select **Eject** to eject the sample loader.

Running the System Startup Program

IMPORTANT Instructions on the software window varies depending on whether you are in semi-automatic injection mode or manual injection mode.

The system startup program takes approximately 8 minutes.

1 Select **Initialize**.

2 Select **System Startup Program** in the Cytometer menu.

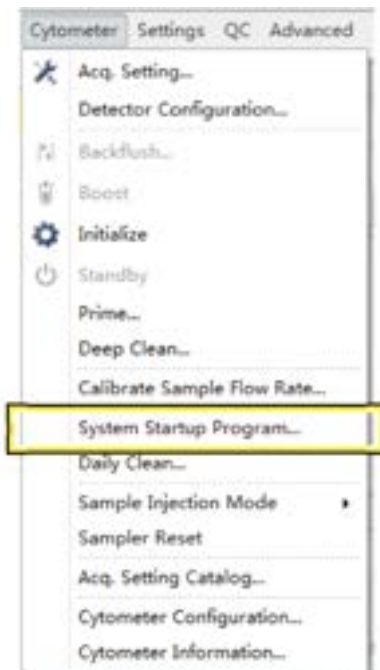

- 3 The System Startup Program window appears. Select **Initialize**.

System Startup Program Window in Semi-Automatic Injection Mode

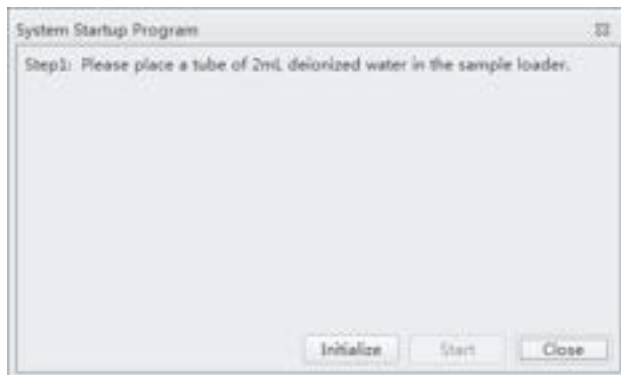

System Startup Program Window in Manual Injection Mode

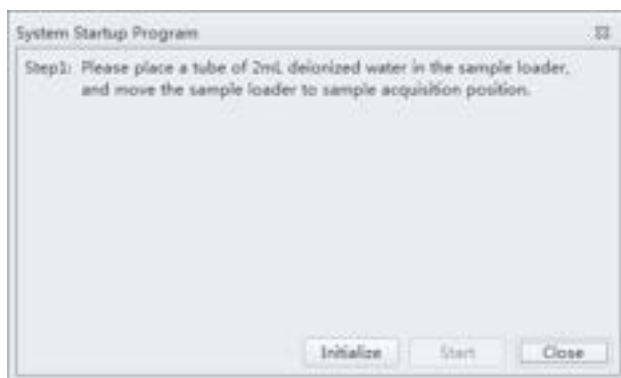

- 4 Wait for the system to initialize. Follow the on screen software prompts, then select **Start**. The instrument begins to prime. This process takes about 1 minute.

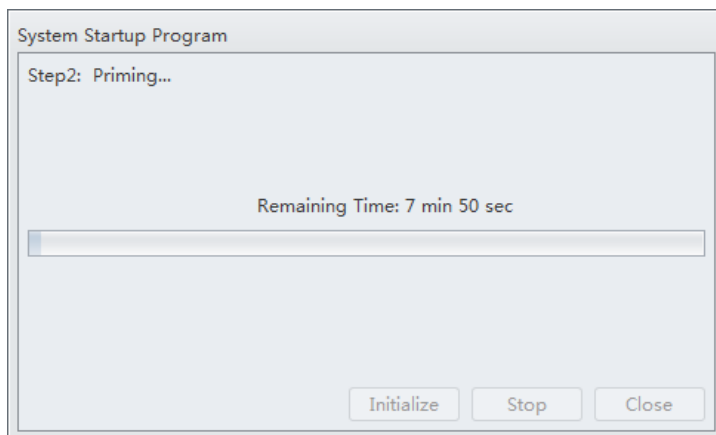

After priming, the system initializes again. The sample is loaded automatically. This process takes about 3 minutes.

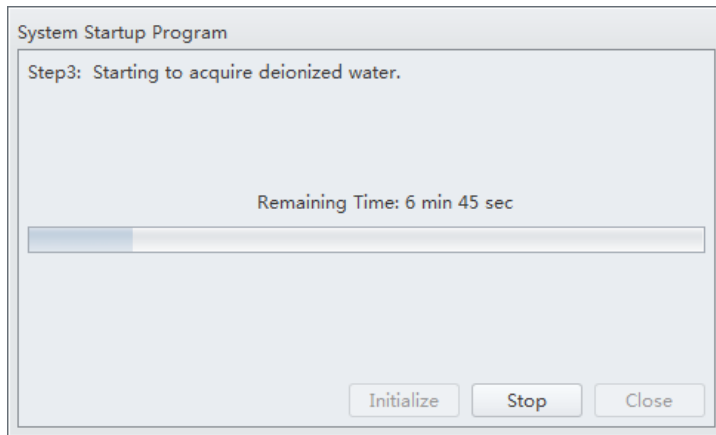

The sample tube is unloaded after sample acquisition has finished. The system uses the remaining time to warm up.

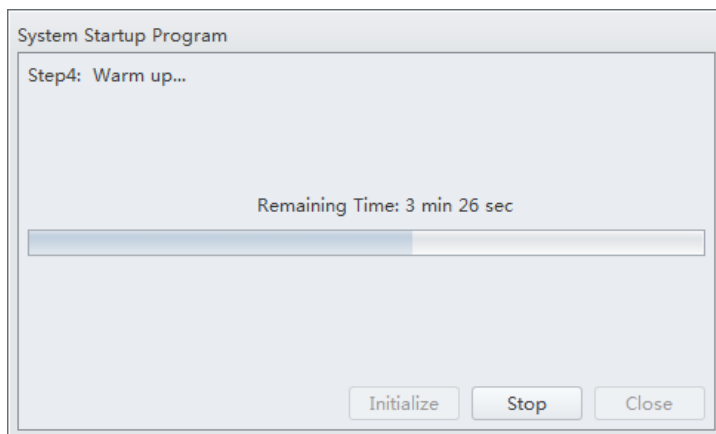

-
- 5 When warm up is finished, select **Close** to quit the startup program. The system is now initialized.

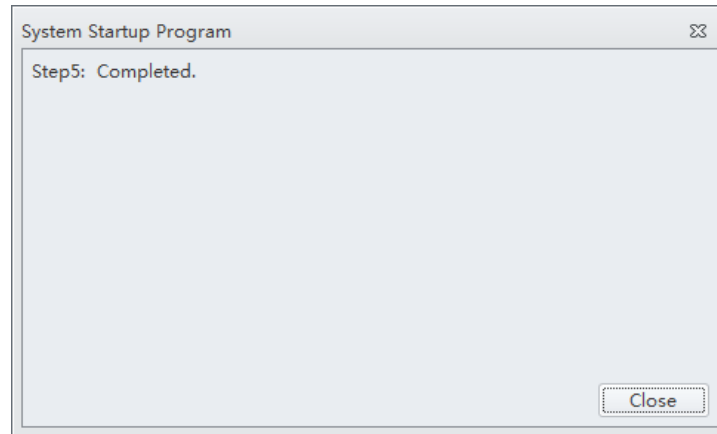

Running the System Startup Program [With Plate Loader]

The system startup program takes approximately 8 minutes.

-
- 1 Select **Initialize**.

- 2 Select **System Startup Program** from the Cytometer menu to open the System Startup Program wizard.

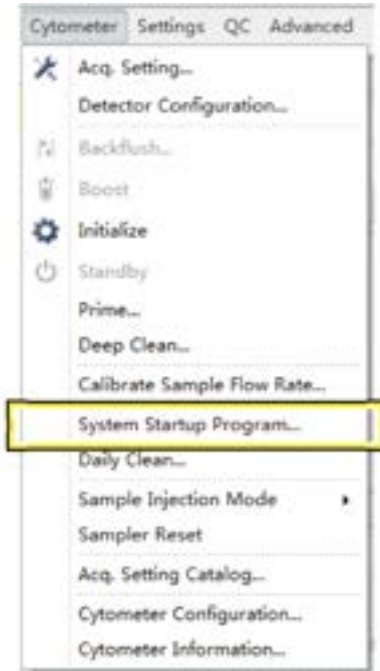

The plate loader automatically ejects the plate holder stage and the System Startup Program window appears.

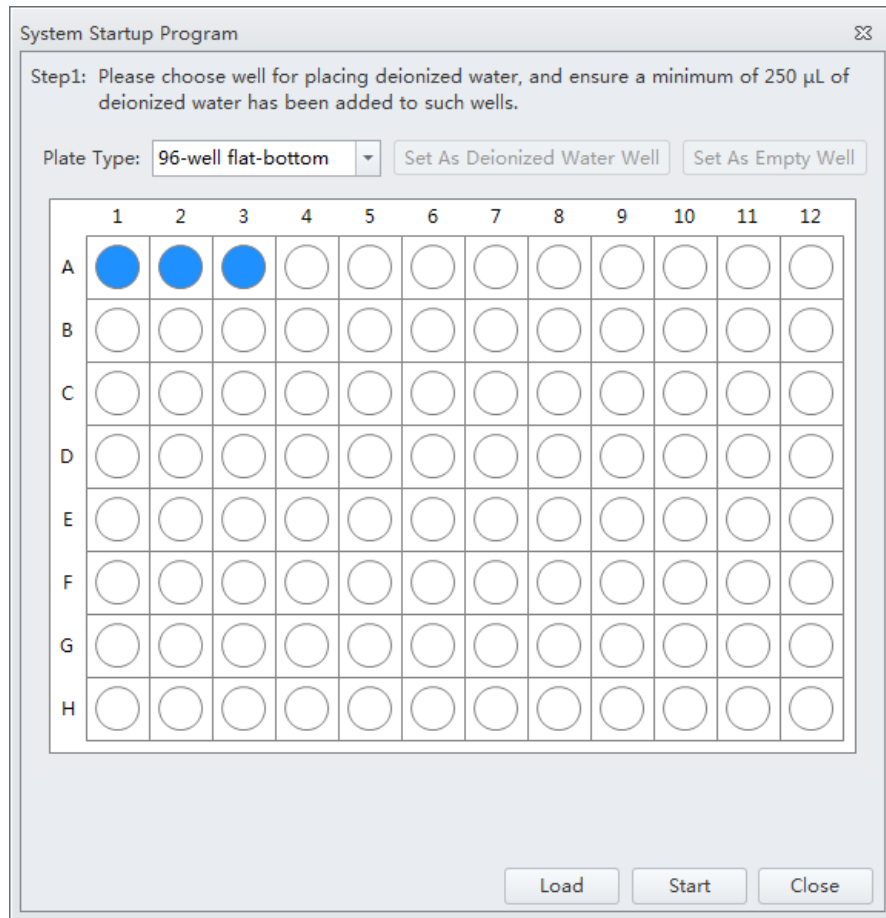

- 3 Follow the on screen software prompts and select the desired wells and select **Set As Deionized Water Well**.

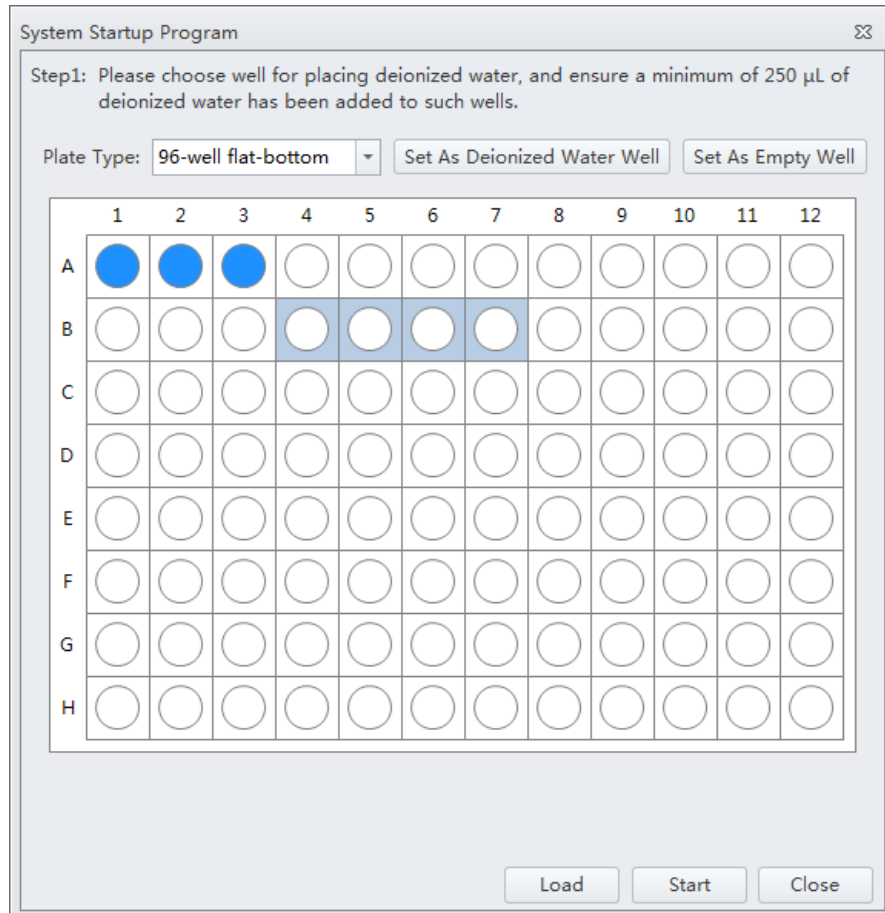

NOTE To deselect water wells, select the desired well and select **Set As Empty Well**.

NOTE Prepare two to six sample wells with deionized water.

- 4 Select **Load** to load the plate.
- 5 Select **start** to start the program. The message *Please confirm that the correct plate is placed properly and press OK* appears. Select **OK**.

Wait for the system to initialize. The instrument begins to prime. This process takes about 1 minute.

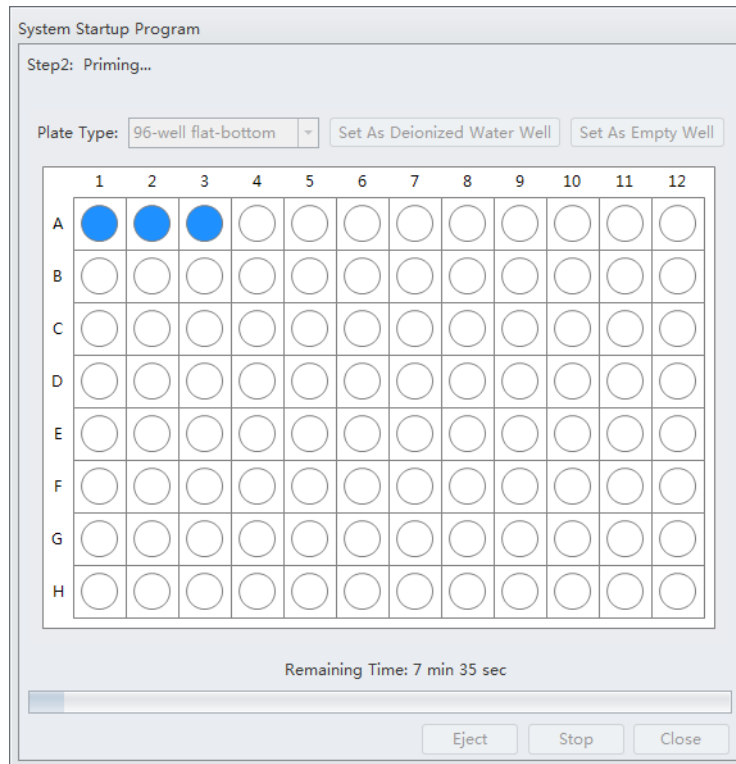

After priming, the system initializes again. The sample is loaded automatically. This process takes about 1 minute per well.

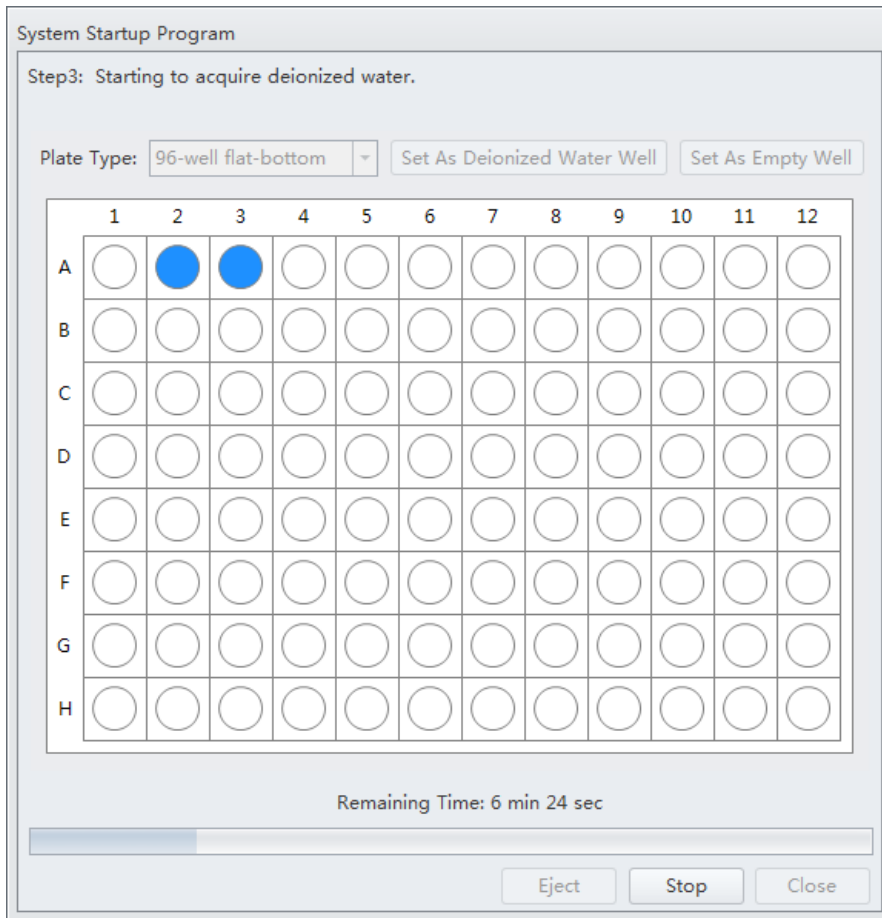

When the system finishes acquiring the selected sample well, it uses the remaining time to warm up.

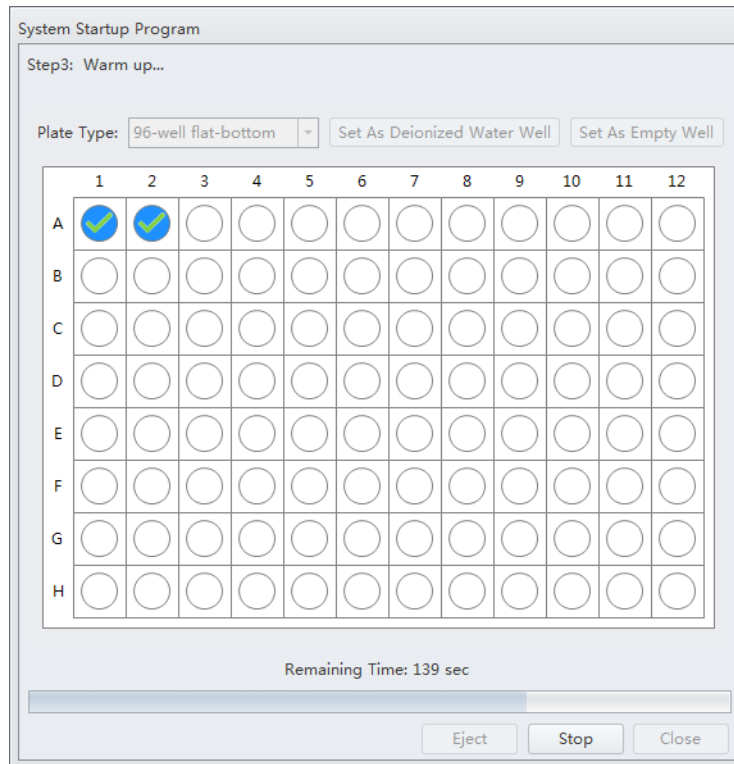

- 6 When warm up is complete the plate loader ejects the plate holder stage. Select **Close** to quit the startup program. The system is now initialized.

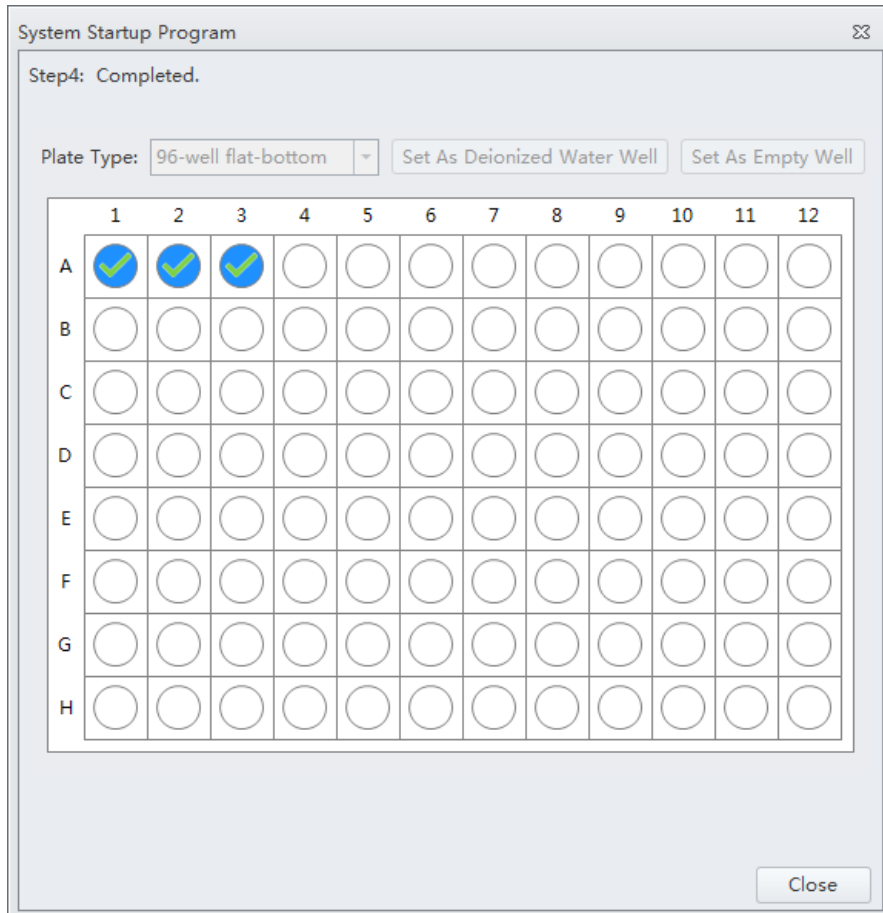

Selecting Experiments from the Start Page

Refer to [Start Page](#) in [CHAPTER 2, Using the CytExpert Software](#).

Initializing the Instrument

- 1 Select **Initialize** in the Data Acquisition Control screen or select **Initialize** in the Cytometer Menu to initialize the instrument.

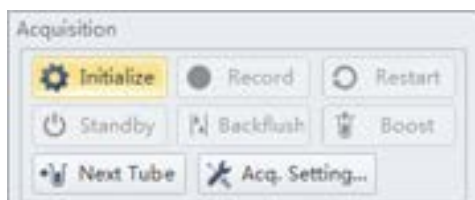

NOTE If the instrument is in Semi-Automatic Injection mode during the initialization process, the sample tube holder automatically shifts into the sample loading position (see [Figure 1.9](#)).

- 2 Wait for the beep indicating that the instrument properly initialized.

NOTE After the instrument initializes, the laser powers on and the fluidics system begins to function. In the initialized state, the laser powers on to achieve operating status, and the sheath fluid flows.

- If you need to execute a task with the Fluid Containers, do so with the instrument in standby state.
- If the instrument remains idle for 10 minutes, the Cytometer automatically enters the standby state.

NOTE After approximately 30 seconds, there should be a continuous flow of waste liquid from the Cytometer to the waste container.

- 3 Proceed to the subsequent operations or select **Standby** to put the instrument in standby state.

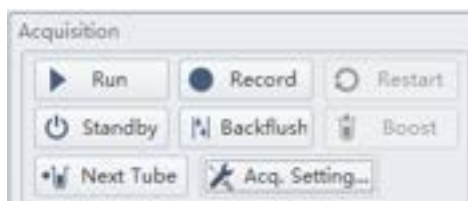

Overview

This chapter provides information on performing daily quality control (QC) on the CytoFLEX flow cytometer and how to confirm that the instrument is working properly within the specified parameters. Quality control allows you to determine whether your instrument can provide adequate signal strength and precision.

The QC process verifies important system functions. The system:

1. Verifies that the unit hardware configuration matches the default configuration specified in the software. Refer to [Verifying, Selecting, Editing, and Creating Detector Configuration](#) in [CHAPTER 5, Data Acquisition and Sample Analysis](#).
2. Measures the laser power of each individual laser and ensures that each laser meets the system specifications.
3. Loads the sample and begins to acquire data.
4. Verifies that the actual laser delays match those set in the software and will adjust the delay within certain parameters.
5. Notifies you manual laser delay adjustments are required. Refer to [Setting Laser Delay](#) in [CHAPTER 11, Replacement/Adjustment Procedures](#).
6. Verifies and calibrates the gain settings. If any of these parameters are outside of the operating limits, the system automatically adjusts these parameters. If the system is unable to adjust these parameters to fall within the operating limits, the system notifies you.

NOTE Beckman Coulter recommends performing QC on a daily basis.

NOTE QC can only be run using the standard detector sets including, laser and band-pass. Refer to [Verifying, Selecting, Editing, and Creating Detector Configuration](#) in [CHAPTER 5, Data Acquisition and Sample Analysis](#) to verify that the default factory detector configuration is selected before running QC.

Workflow:

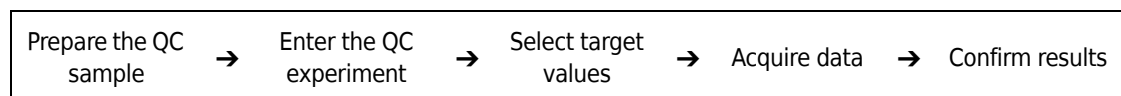

This chapter contains information on:

- [Preparing the QC Sample](#)
- [Preparing the QC Sample \[With Plate Loader\]](#)
- [Importing Lot-Specific Target Values](#)
- [Collecting QC Data](#)
- [Collecting QC Data \[With Plate Loader\]](#)

- [Confirming Results](#)

Preparing the QC Sample

Required materials

The following materials are required to complete the QC process:

- CytoFLEX Daily QC Fluorospheres
- CytoFLEX Sheath Fluid or another nonionic strength sheath fluid
- Sample tubes (12 x 75 mm).
- Vortexer

Preparation process

- 1 Take one sample tube and label it as the QC sample tube.
- 2 Add approximately 1 mL of deionized water to the sample tube.
- 3 Use the vortexer or shake vigorously to thoroughly mix the bottle of CytoFLEX Daily QC Fluorospheres.
- 4 Add three drops of CytoFLEX Daily QC Fluorospheres to the sample tube.
- 5 Use the vortexer to mix the sample tube until a uniform mixture is achieved.
- 6 Place the sample tube in a dark location at 2-8 °C until ready to load the tube into the instrument for QC.

NOTE Tubes containing diluted CytoFLEX Daily QC Fluorospheres may be stored sealed in a dark location at 2-8 °C for up to 5 days.

Preparing the QC Sample [With Plate Loader]

Required Materials

The following materials are required to complete the QC process:

- CytoFLEX Daily QC Fluorospheres
- CytoFLEX Sheath Fluid or another nonionic strength sheath fluid
- Well plate
 - 96-well flat-bottom
 - 96-well V-bottom
 - 96-well U-bottom
- Vortexer

Preparation Process

-
- 1** Take one 96-well plate and label one well as the QC sample well.

 - 2** Use the vortexer or shake vigorously to thoroughly mix the bottle of CytoFLEX Daily QC Fluorospheres.

 - 3** Add one drop of CytoFLEX Daily QC Fluorospheres to the sample well.

 - 4** Add approximately 200 μ L of deionized water to the sample well.

 - 5** Place the well plate in a dark location at 2-8 °C until ready to load the well plate into the instrument for QC.

NOTE Well plates containing diluted CytoFLEX Daily QC Fluorospheres may be stored sealed in a dark location at 2-8 °C for up to 5 days.

Importing Lot-Specific Target Values

Import lot-specific target values for each new lot of beads.



Risk of erroneous QC results. Different target value information correspond to different lot numbers. Selecting the wrong lot number will lead to erroneous QC results.

- 1 Open the CytExpert QC screen.
- 2 Select **Target Library** from the Settings menu. The Target Library window appears.

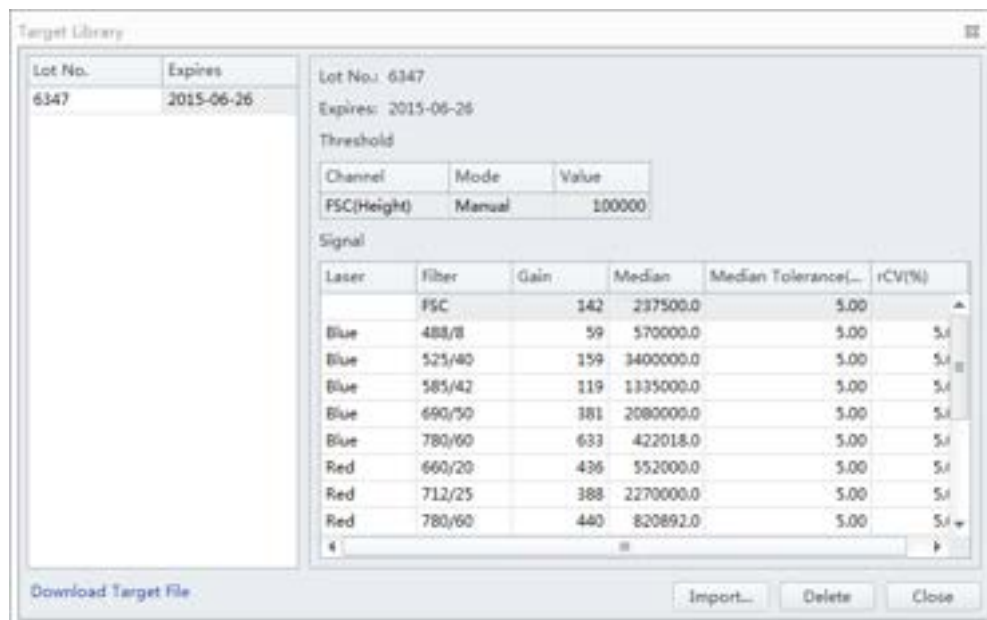

- 3 Select **Download Target File**. The Beckman Coulter Technical Documents and Software Downloads page appears.



NOTE If your CytoFLEX Workstation does not have access to the internet, navigate to <https://www.beckmancoulter.com/wsrportal/page/softwareDownloadSearch> using a computer with access to the internet and save the file to a USB drive. If the website is not accessible, contact your Beckman Coulter Representative.

- 4 In the Search By Product section of the screen, select the following:
 - a. Select **Research & Discovery** from the Market Segment drop-down menu.
 - b. Select **Flow Cytometry** from the Product Line drop-down menu.
 - c. Select **Instruments** from the Product Series drop-down menu.
 - d. Select **CytoFLEX** from the Product drop-down menu.
 - e. Select **CytoFLEX QC Fluorospheres Target** from the Software Name drop-down menu.
 - f. Select **All** from the Lot Number drop-down menu.

g. Select **English** from the Language drop-down menu.

5 Select **Search**.

6 The search results appear below the Search By Lot Number tab.

Software Download Search Results

First Prev 1 Next Last View 20 per page

Software Name*	Product	Lot No.	Version	Item/REF. NO.	Release Date	Language
CytO-FLEX GC Fluorespheres 7 Target Values	CytoFLEX	12345 ...		80000		English

First Prev 1 Next Last Displaying 1 to 1 of 1 software found.

- 7 Select **CytoFLEX QC Fluorospheres Target Values** under the Software Name column. The CytoFLEX QC Fluorospheres Target Values page appears.

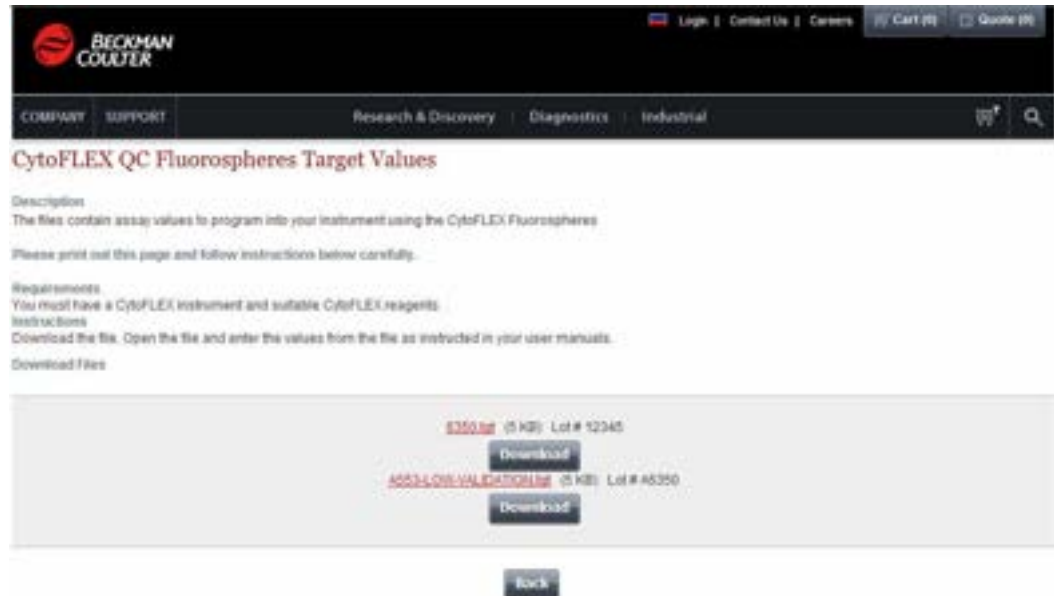

- 8 Select **Download** under the correct lot number from the CytoFLEX QC Fluorospheres Target Values page. The File Download pop up window appears.





- 9 Select **Save**. Save the file to the desired file path.
- 10 Select **Import** from the Target Library window in the CytExpert software.
- 11 Navigate to the file saved in step 9 and select **Open**.

- 12 Select **Close** to exit the Target Library window.

Collecting QC Data

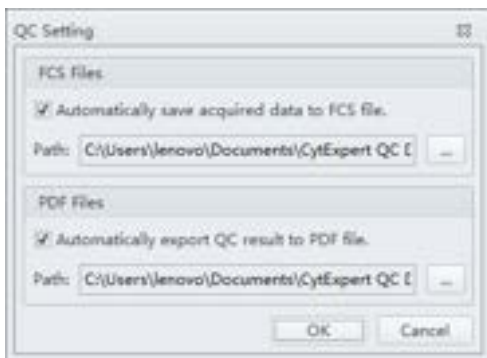
QC data and reports are saved by default. Select **QC Setting** in the Settings menu to change the default save settings or modify the file path these files are saved to.



- 1 Double-click  to start the CytExpert software.
 - a. Ensure that the **Connected** icon on the Status Bar near the bottom-left side of the display is green.



- b. If the icon is not green, ensure that the Cytometer USB is securely connected to the Workstation and restart the Workstation.
- 2 Verify the detector configuration. Refer to [Verifying, Selecting, Editing, and Creating Detector Configuration](#) in [CHAPTER 5, Data Acquisition and Sample Analysis](#).

NOTE Ensure that the instrument configuration is properly configured for the QC experiment. The QC experiment may not be completed or may end in erroneous results if incorrect settings are chosen. Beckman Coulter recommends using the factory configuration and ensuring that the proper optical filters are in place.

- 3 Select **Start QC** in the QC menu to access the QC experiment.

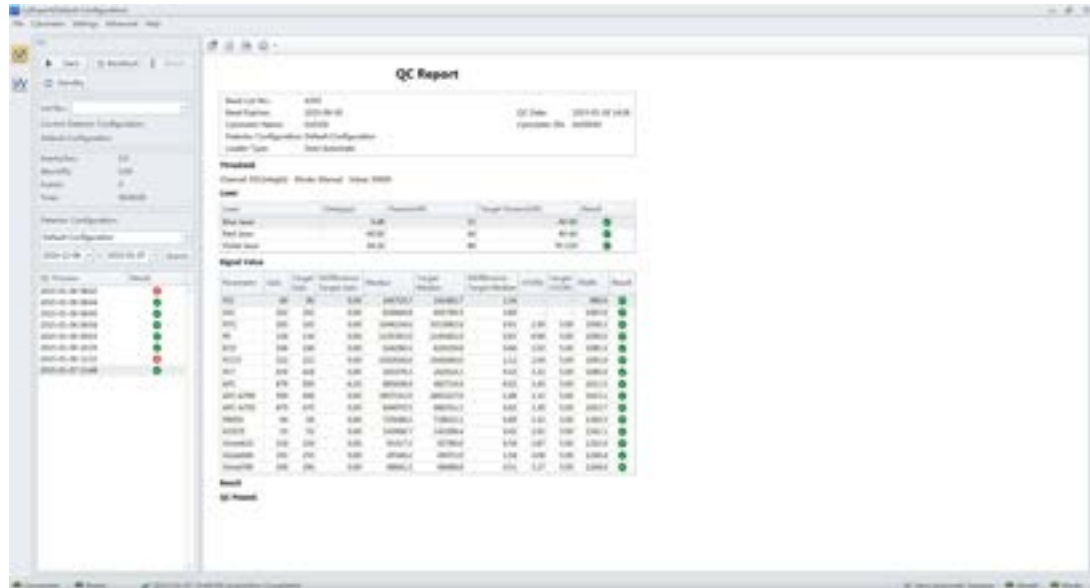

Ensure that the QC bead lot number is selectable in the Lot No. drop down menu. If the lot number is not selectable, refer to [Importing Lot-Specific Target Values](#), then select the proper lot number.

- 4 Select **Initialize**.
- 5 Insert the prepared QC sample tube (see [Preparation process](#)) into the tube holder.
- 6 Select **Start** to load the sample and begin to run the QC procedure.

Completed processes appear on the left. Plots appear on the right. The QC experiment sequentially detects configuration, laser power, laser delay, signal strength, and coefficient of variation.



During QC, the software automatically seeks the CytoFLEX Daily QC Fluorospheres and computes the results. The software returns to the QC screen after the QC run is complete.

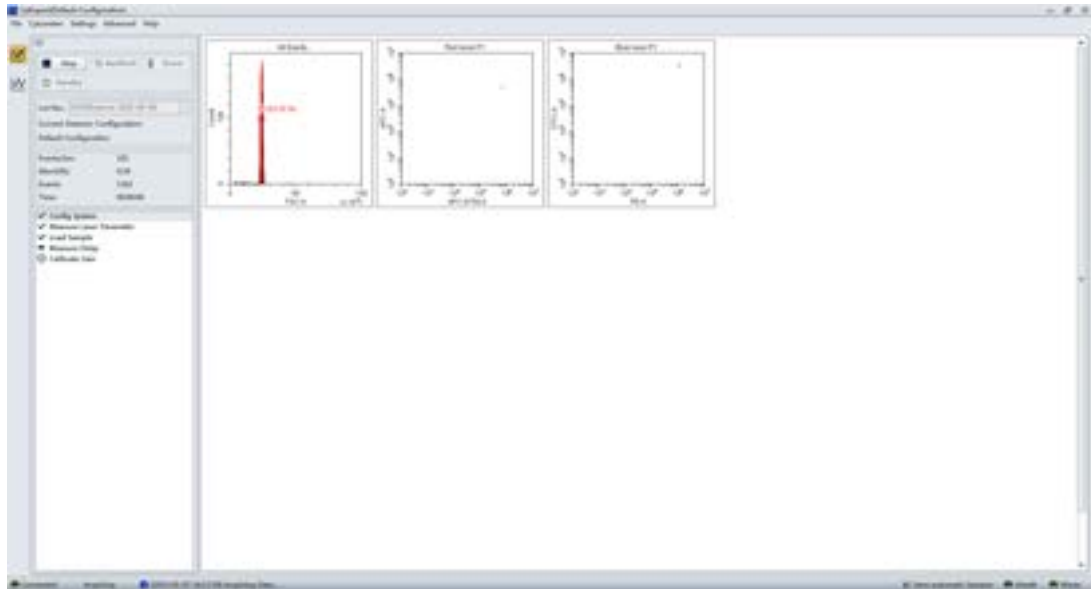

- 7 If the sampling rate is too low, the Cytometer stops the QC run and displays a prompt that the QC run fails to reach the required event flow rate. This is not considered a QC failure. If this situation occurs, increase the sample concentration by adding one drop of CytoFLEX Daily QC Fluorospheres to the sample tube and then perform the experiment.

Collecting QC Data [With Plate Loader]

QC data and reports are saved by default. Select **QC Setting** in the Settings menu to change the default save settings or modify the file path these files are saved to.

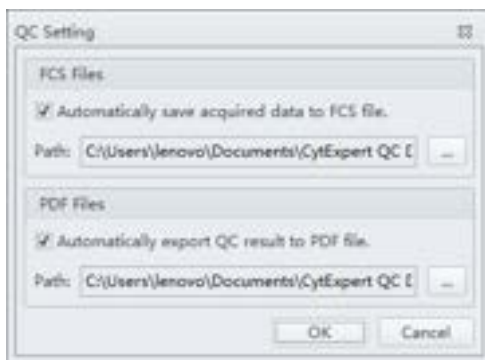

- 1 Double-click  to start the CytExpert software.
 - a. Ensure that the **Connected** icon on the Status Bar near the bottom-left side of the display is green.



- b. If the icon is not green, ensure that the Cytometer USB is securely connected to the Workstation and restart the Workstation.

- 2 Verify the detector configuration. Refer to [Verifying, Selecting, Editing, and Creating Detector Configuration](#) in [CHAPTER 5, Data Acquisition and Sample Analysis](#).

NOTE Ensure that the instrument configuration is properly configured for the QC experiment. The QC experiment may not be completed or may end in erroneous results if incorrect settings are chosen. Beckman Coulter recommends using the factory configuration and ensuring that the proper optical filters are in place.

- 3 Select **Start QC** in the QC menu to access the QC experiment.

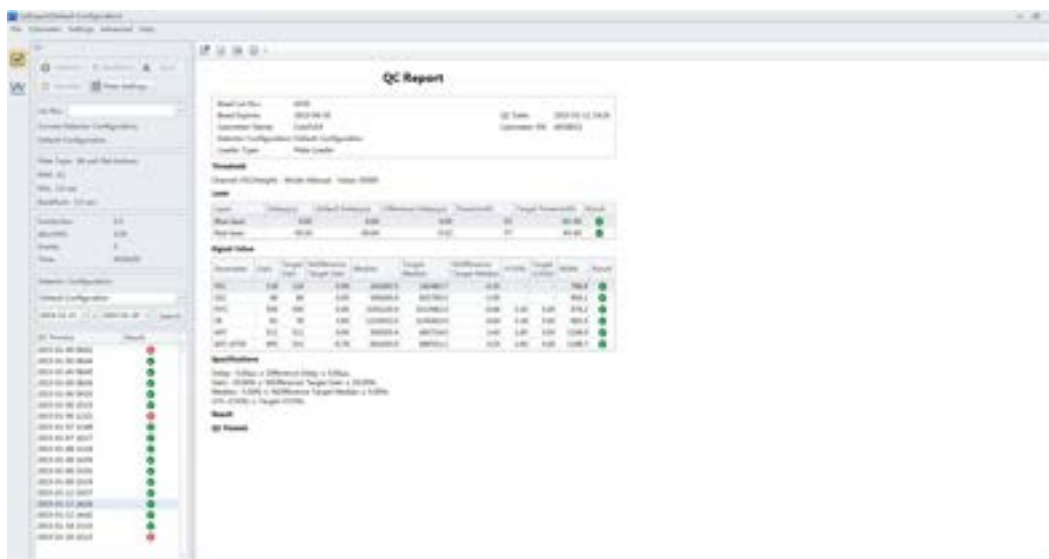

Ensure that the QC bead lot number is selectable in the Lot No. drop down menu. If the lot number is not selectable, refer to [Importing Lot-Specific Target Values](#) in [CHAPTER 4, Instrument Quality Control](#), then select the proper lot number.

- 4 Select **Initialize**.

- 5 Select **Eject**.

6 Insert the prepared QC well plate (see [Preparation Process](#)) into the plate holder.

7 Select . The Plate Settings window appears.

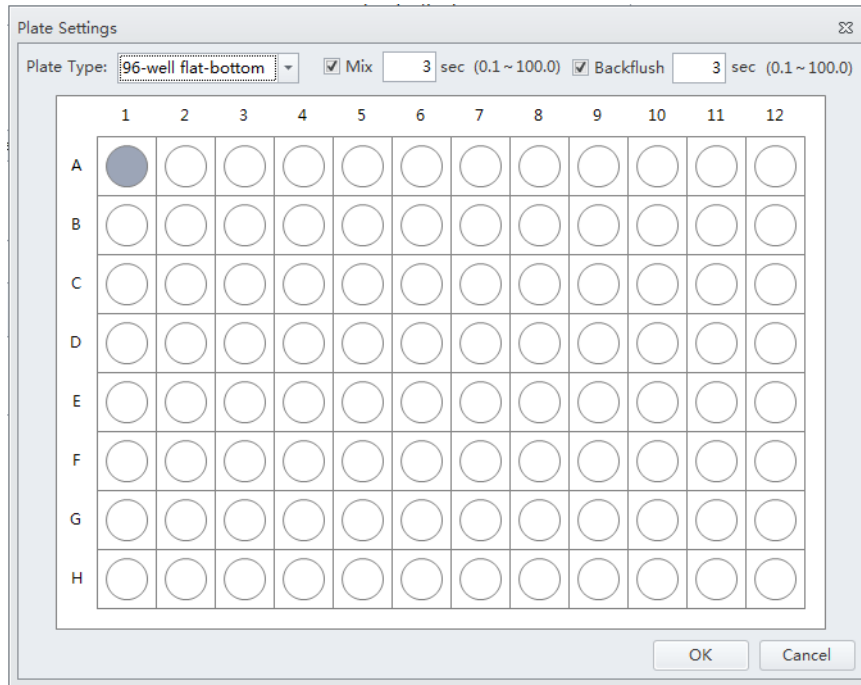

IMPORTANT Ensure the well position on the plate matches the well position selected in the software.

8 Select the appropriate QC well.

- 9 Select the desired plate type from the Plate Type dropdown menu.

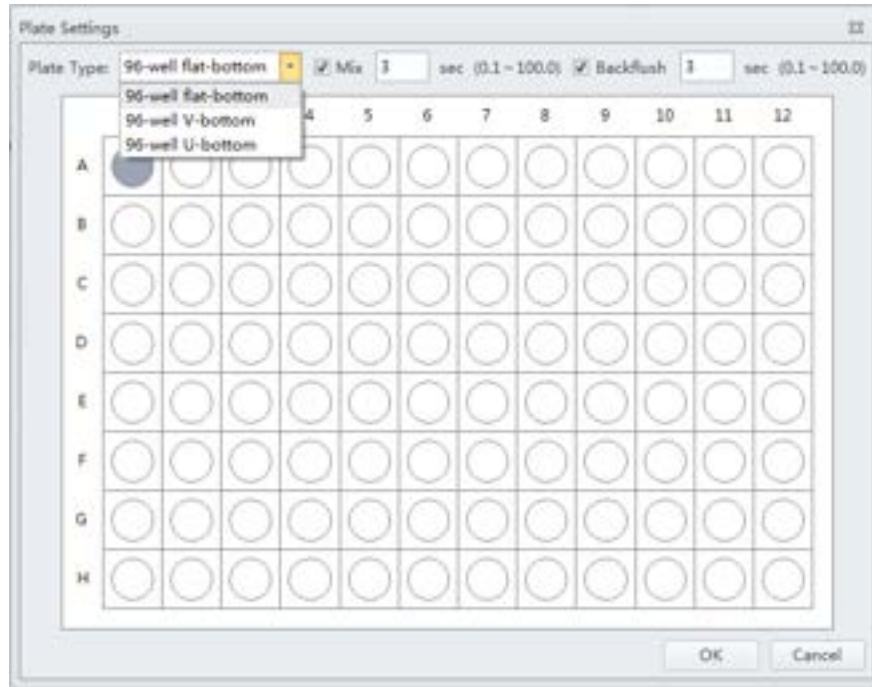

- 10 Select the Mix and Backflush settings in the top of the Plate Settings window.

- 11 Select **OK**.

- 12 Select **Load**. The plate loader loads the plate into the instrument.

- 13 Select **Start** to load the sample and begin to run the QC procedure. The message *Please confirm that the correct plate is placed properly and press OK* appears. Select **OK**.

Completed processes appear on the left. Plots appear on the right. The QC experiment sequentially detects configuration, laser power, laser delay, signal strength, and coefficient of variation.



During QC, the software automatically seeks the CytoFLEX Daily QC Fluorospheres and computes the results. The software returns to the QC screen after the QC run is complete.

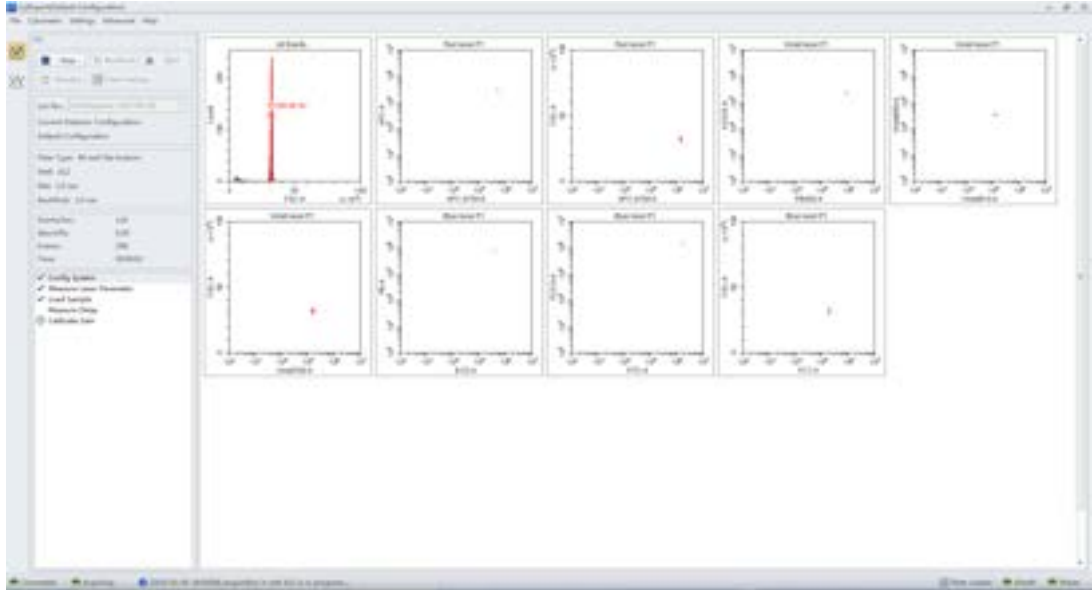

- 14 If the sampling rate is too low, the Cytometer stops the QC run and displays a prompt that the QC run fails to reach the required event flow rate. This is not considered a QC failure. If this situation occurs, increase the sample concentration by adding one drop of CytoFLEX Daily QC Fluorospheres to the sample tube and then perform the experiment.

Confirming Results

Select **Start QC** in the QC menu to return to the QC Setting screen at any time to review completed experiment results.

- 1 Select the desired default configuration and date range from the drop-down menus located on the left side of the QC screen and select **Search** to sort by the configuration used during the specified date range.

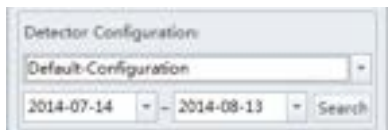

NOTE If a date range is not specified, the QC screen displays all QC results for the last 30 days.

- 2 Select a QC run from the QC Process list on the left and a QC report appears on the right.



QC Process	Result
2015-10-27 11:08	✘
2015-10-27 11:11	✔
2015-10-28 11:45	✔

NOTE The results column indicates a passing QC result with a ✔ and a failed QC result with ✘.

QC results must meet the following criteria to pass:

- The gain differences must be $\leq 20\%$ from the target gain.
- The median fluorescence intensity (MFI) differences must be $\leq 5\%$ from the target MFI.
- The rCV must be $\leq 5\%$.

NOTE The CytoFLEX Daily QC Fluorospheres rCV pass QC criteria is $\leq 5\%$.

The report area on the right displays detailed experiment results, including laser power, delay, testing conditions, and signal results. The same  and  symbols are used to indicate each result. For items that fail, values falling outside the prescribed range are displayed in red font. In the Comment area, an explanation appears for each failed item.



QC Report

Bead Lot No:	A555	QC Date:	2015-01-20 10:23
Bead Expires:	2015-09-30	Cytometer SN:	AR38012
Cytometer Name:	CytoFLEX		
Detector Configuration:	Default-Configuration		
Loader Type:	Semi Automatic		

Threshold

Channel: FSC(Height) Mode: Manual Value: 50000

Laser

Laser	Delay(μs)	Default Delay(μs)	Difference Delay(μs)	Power(mW)	Target Power(mW)	Result
Blue laser	0.00	0.00	0.00	53	40-60	
Red laser	-37.12	-39.36	2.24	53	40-60	

Signal Value

Parameter	Gain	Target Gain	%Difference Target Gain	Median	Target Median	%Difference Target Median	rCV(%)	Target rCV(%)	Width	Result
FSC	20	107	-81.31	242486.0	242482.7	0.00	-	-	1117.1	
SSC	14	96	-85.42	608237.2	601799.5	1.07	-	-	1187.8	
FITC	19	426	-95.54	3279233.0	3313982.0	-1.05	2.27	5.00	1188.6	
PE	26	71	-63.38	1117258.0	1145402.0	-2.46	2.22	5.00	1194.0	
APC	3000	472	535.59	29386.1	483724.0	-93.93	11.13	5.00	1700.8	
APC-A750	3000	495	506.06	20604.3	689351.1	-97.01	17.46	5.00	1433.5	

Specifications

Delay: $-5.00\mu\text{s} \leq \text{Difference Delay} \leq 5.00\mu\text{s}$.
 Gain: $-20.00\% \leq \% \text{Difference Target Gain} \leq 20.00\%$.
 Median: $-5.00\% \leq \% \text{Difference Target Median} \leq 5.00\%$.
 rCV: $\text{rCV}(\%) \leq \text{Target rCV}(\%)$.

Result

QC Failed.

Comment



The difference between FSC gain and target is more than 20%.
 The difference between SSC gain and target is more than 20%.
 The difference between FITC gain and target is more than 20%.
 The difference between PE gain and target is more than 20%.
 APC gain calibration was failed, median value is out of the target value range.
 APC-A750 gain calibration was failed, median value is out of the target value range.

If QC fails, follow the procedure below:

- Verify whether the beads used were within their shelf life and stored in accordance with the appropriate instruction manual.
- Verify whether the allocated sample tube was prepared as required and correctly positioned.
- Run [Priming the Flow Cell](#) in [CHAPTER 11, Replacement/Adjustment Procedures](#), and retest.

- d. Run **Daily Clean** in [CHAPTER 10, Cleaning Procedures](#), and retest.
- e. Run **Deep Clean Procedure** in [CHAPTER 10, Cleaning Procedures](#), and retest.
- f. Repeat Steps [c-d](#).

NOTE If QC fails two times in a row on the same day after repeating Steps [a-f](#), contact your Beckman Coulter Representative.

-
- 3 If necessary, you can select  (for CSV format) or  (for PDF format) in the top left corner of the report area to export the QC results.

-
- 4 Select **Close QC** in the File menu to exit the QC screen.
-

Creating Levey Jennings Charts

- 1 Select **Start QC** in the QC menu to open the QC screen.
-
- 2 Select LJ chart  on the left side of the screen.

IMPORTANT When there are multiple plots, select which lot to create the LJ charts from.

- 3 Select LJ Chart Settings  on the top of the LJ Chart screen. The LJ Chart Settings screen appears.

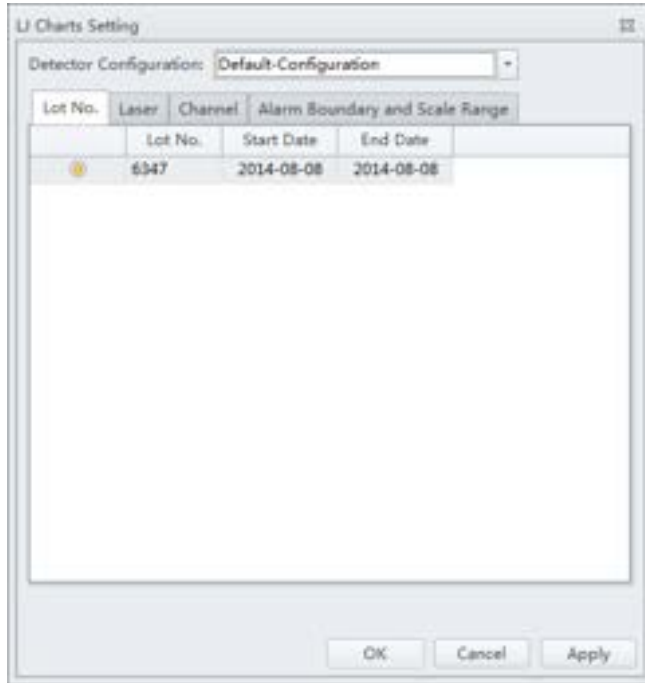

- 4 Select the **Laser** tab, and select the power and/or delay check boxes for each laser as needed.



- 5 Select the **Channels** tab, and select each channel check box as needed.

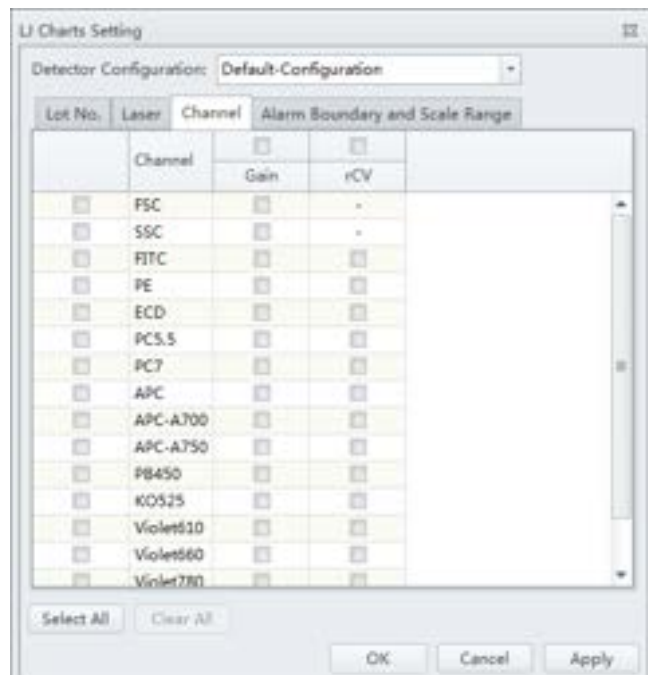

- 6 Select **Apply**.
- 7 Select **OK**.
- 8 Select the Levey Jennings plot and select the start and end date from the drop down boxes at the top of the LJ Chart screen to specify the desired date range.

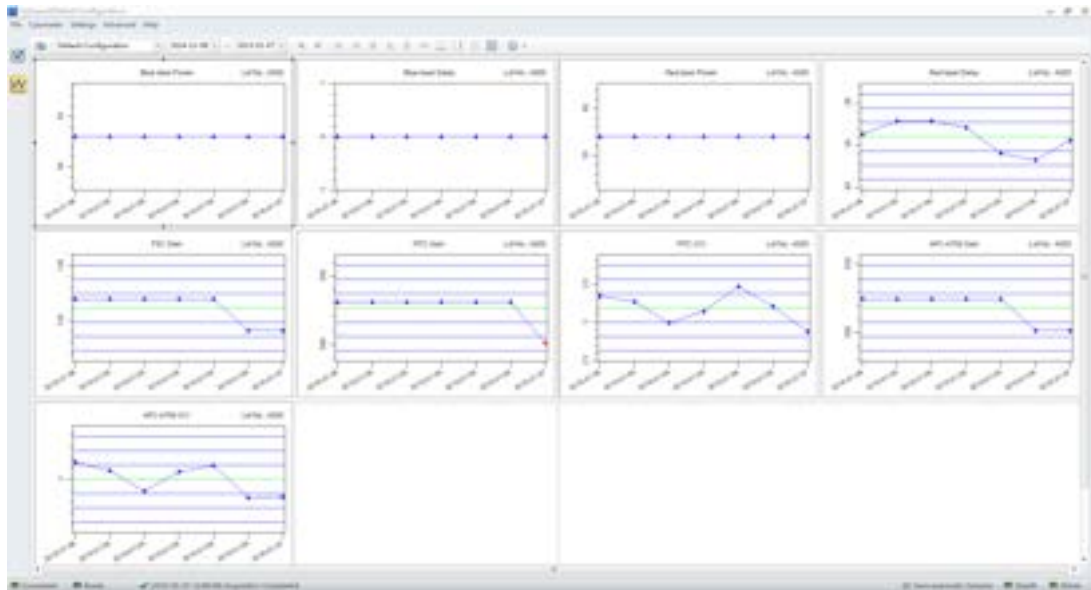

NOTE Select the desired configuration and date range from the drop-down menus located at the top of the LJ Chart screen to sort by the configuration used during the specified date range.



- 9 Select **Close QC** in the File menu to exit the QC screen.

QC Result Manager

The QC Result Management window can be used to search, delete, print, and export QC results.

To access the QC Result Manager, right click the desired QC result and select **QC Result Manager** in the QC screen. The QC Result Manager window appears.

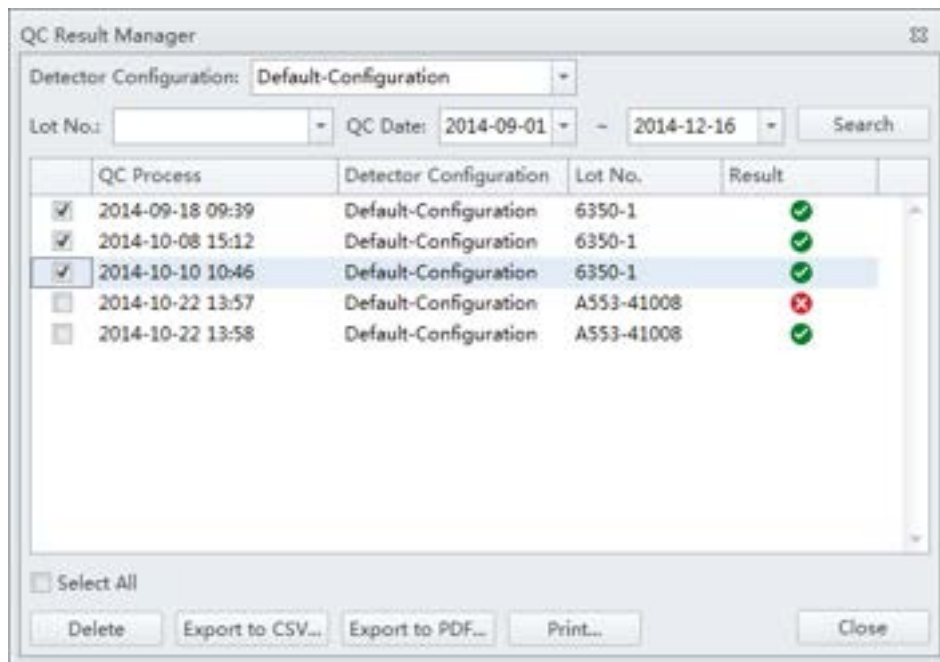
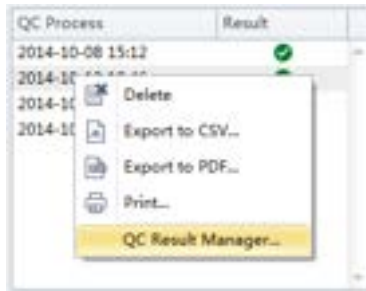

Data Acquisition and Sample Analysis

Overview

This chapter contains information on how to use your CytoFLEX flow cytometer, including data acquisition, analyzing and exporting results, and compensation procedures that will be executed manually during the process.

Workflow:

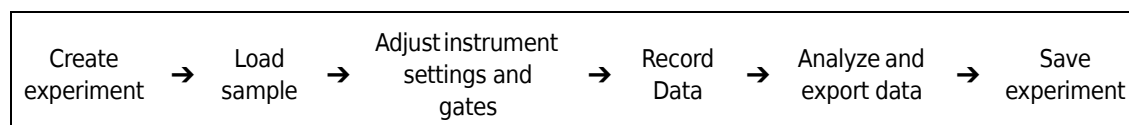

This chapter contains information on:

- [Creating an Experiment](#)
- [Creating an Experiment \[With Plate Loader\]](#)
- [Load Sample and Record Data](#)
- [Configuring Acquisition Settings](#)
- [Analyzing and Exporting Data](#)
- [Saving the Experiment](#)

Creating an Experiment

- 1 Open the CytExpert software and confirm that the instrument is connected. Refer to [Opening the Software](#) in [CHAPTER 3, Daily Startup](#).
- 2 Verify the detector configuration. Refer to [Verifying, Selecting, Editing, and Creating Detector Configuration](#).
- 3 Create or open an experiment using one of the following methods:
 - Create a new experiment:
 - Select **New Experiment** on the Start page, specify the file path, and save the experiment.
 - Or

- Select **New Experiment** in the File menu, specify the file path, and save the experiment.
- Create a new experiment from a template:
 - Select **New Experiment from Template** on the Start page. Select **Browse** next to New Experiment and specify the file path for the new experiment, then select **Browse** next to Template and specify the file path to the existing template.
 - Or
 - Select **New Experiment from Template** in the File menu, specify the file path and save the experiment.
 - Or
 - Select the Template tab on the Start page and select the template from the list of recently used templates. Specify the file path and save the experiment.
- Open an existing experiment:
 - Select **Open Experiment** on the Start page, specify the file path and save the experiment.
 - Or
 - Select **Open Experiment** in the File menu, specify the path and save the experiment.
 - Or
 - Select the Experiment tab on the Start page and select the experiment from the list of recently opened experiments. Specify the file path and save the experiment.

NOTE Experiments are saved as an .xit file. Template are saved as an .xitm file.

NOTE If you need to change the default save path, select **Options** in the Settings menu and modify the Default Path displayed to the right of the Experiment tab. Then select **OK**.

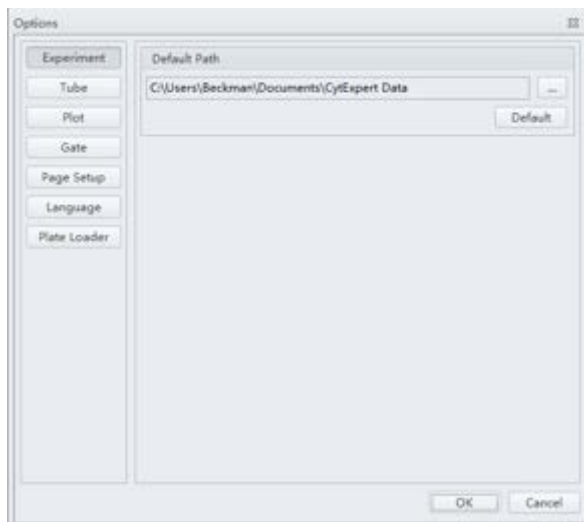

Creating an Experiment [With Plate Loader]

- 1 Create an experiment. Refer to [Creating an Experiment](#) in CHAPTER 5, [Data Acquisition and Sample Analysis](#).

- 2 Select . The Plate window appears.

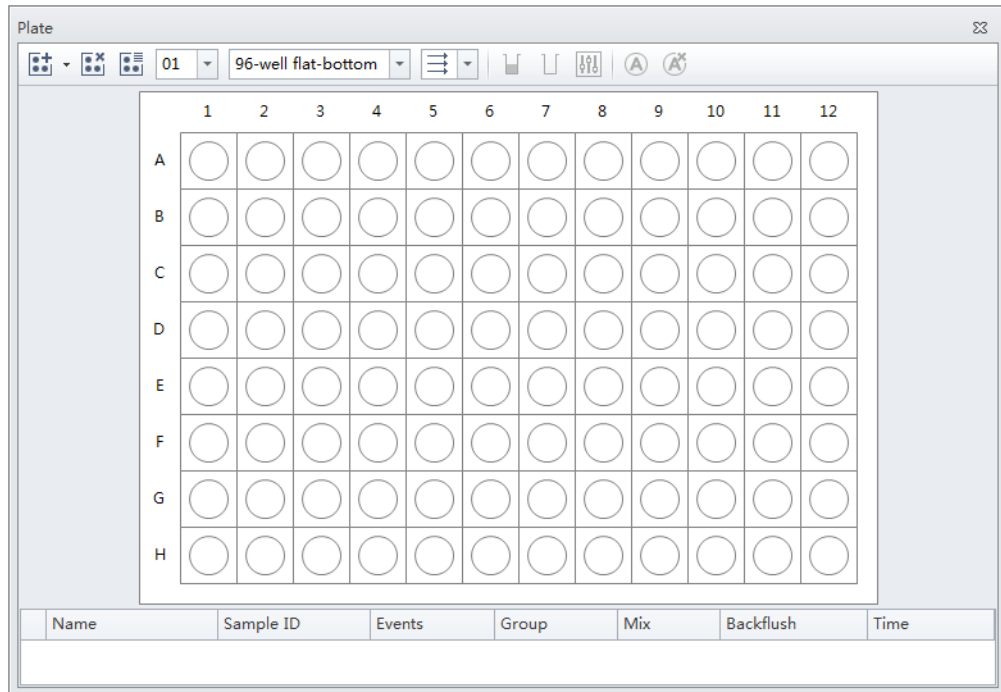

- 3 Select the Add Plate dropdown and select **Add Plate**.

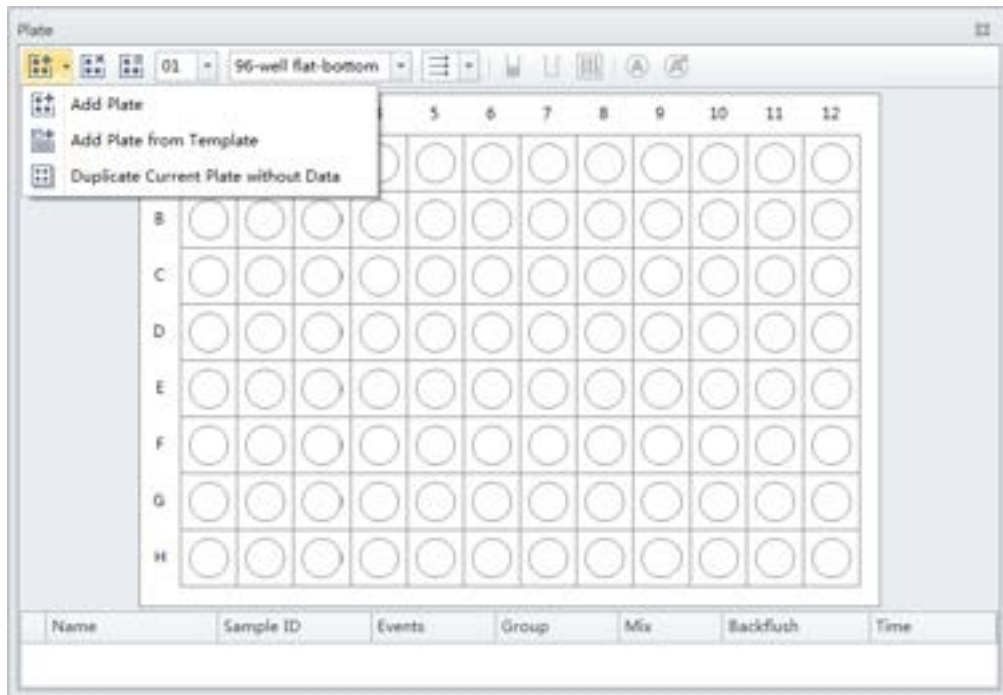

The Add Plate window appears.

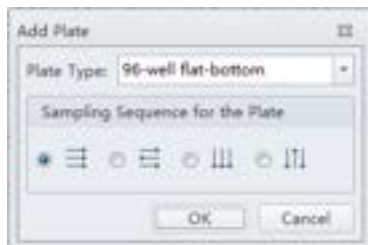

NOTE Select **Add Plate from Template** to add a plate template with preset plate settings.

NOTE Select **Duplicate Current Plate without Data** to create a copy of the selected plate without data.

- 4 Select the Plate type from the dropdown.
- 5 Select the direction of the workflow from the sampling sequence from the plate section of the window.
- 6 Select **OK**.

Setting Sample Wells

Once the plate protocol is created, the plate window appears. Refer to [Figure 5.1](#).

Figure 5.1 Plate Window

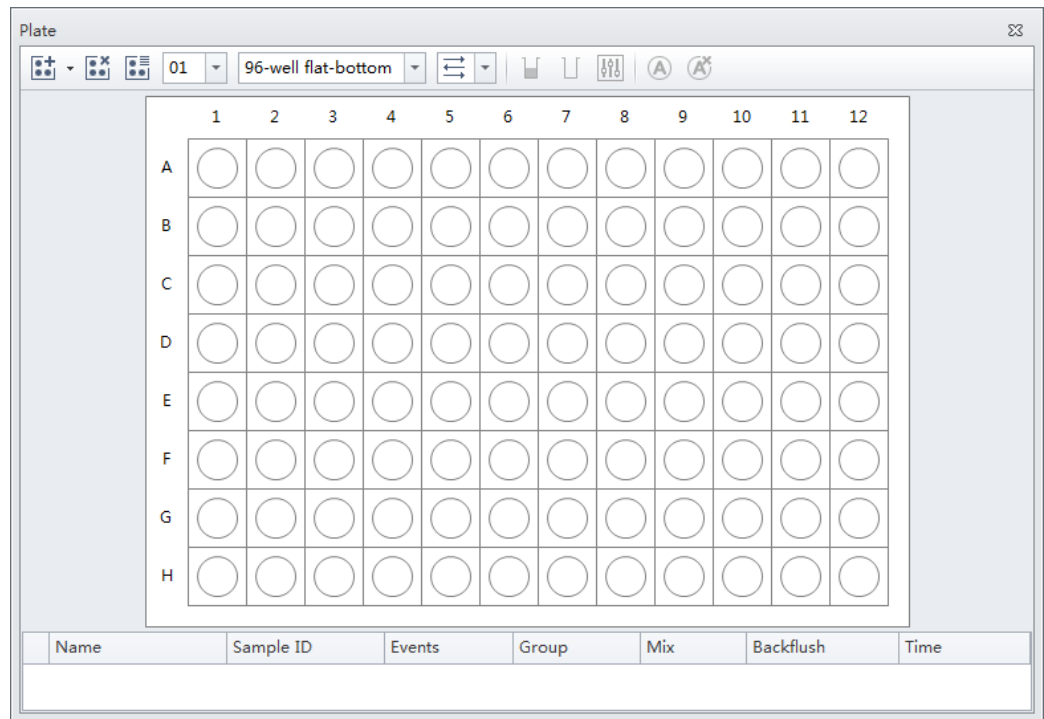

	Empty well
	The well with color is set as sample well, but is not set for Auto Record
	The well is set as sample well, and is ready for Auto Record. The number labeled at the right bottom shows the order of auto record.
	A blue check mark means the data is acquired, not recorded.
	A green check mark means the data is recorded.
	A red cross mark means the data is recorded by Auto Record mode. But the acquisition is terminated abnormally. For example, the well is skipped or the acquisition is manually stopped.

- 1 Left click and drag your mouse to highlight the desired wells or hold the Control key and select each desired well.

- 2 Select  or right-click the selected wells and select **Set As Sample Wells**. The Set As Sample Wells window appears.

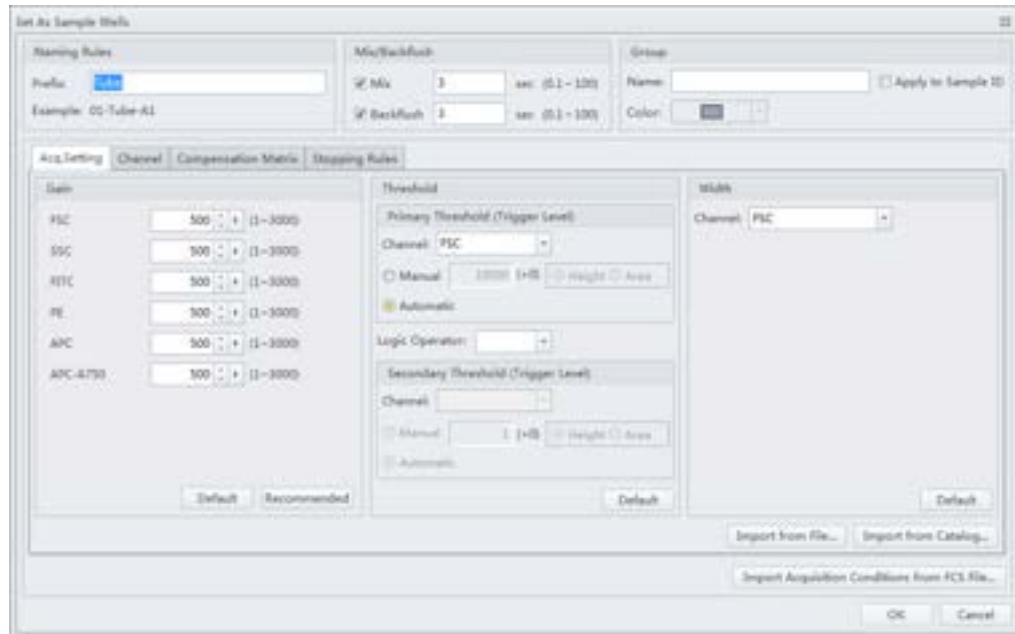

NOTE Select  or right-click and select **Set as Empty Wells** to reset selected wells as empty.

- 3 Enter the name in the Prefix box in the Naming Rules section of the window.
- 4 Select the desired Mix and Backflush settings from the Mix/Backflush section of the window.
- 5 Enter the Group Name in the Name box in the Group section of the window.
- 6 Select the sample well color using the color dropdown under the Group section of the window.

7 Select the desired acquisition settings under the Acq. Setting tab.

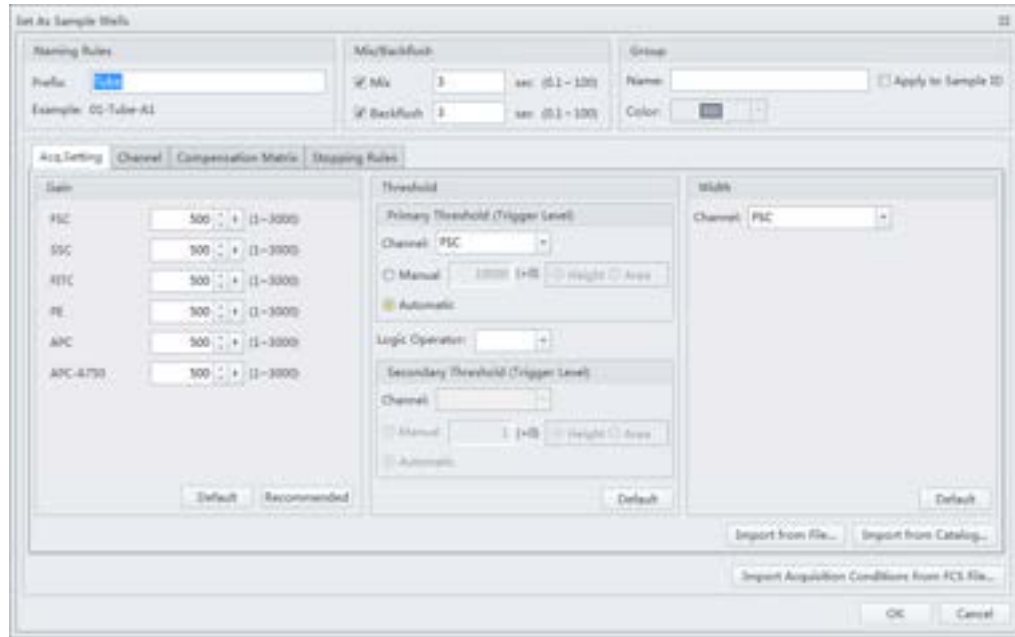

NOTE Select **Import from File** to import the settings from a FCS file.

8 Select the channels and create label names under the Channel tab.

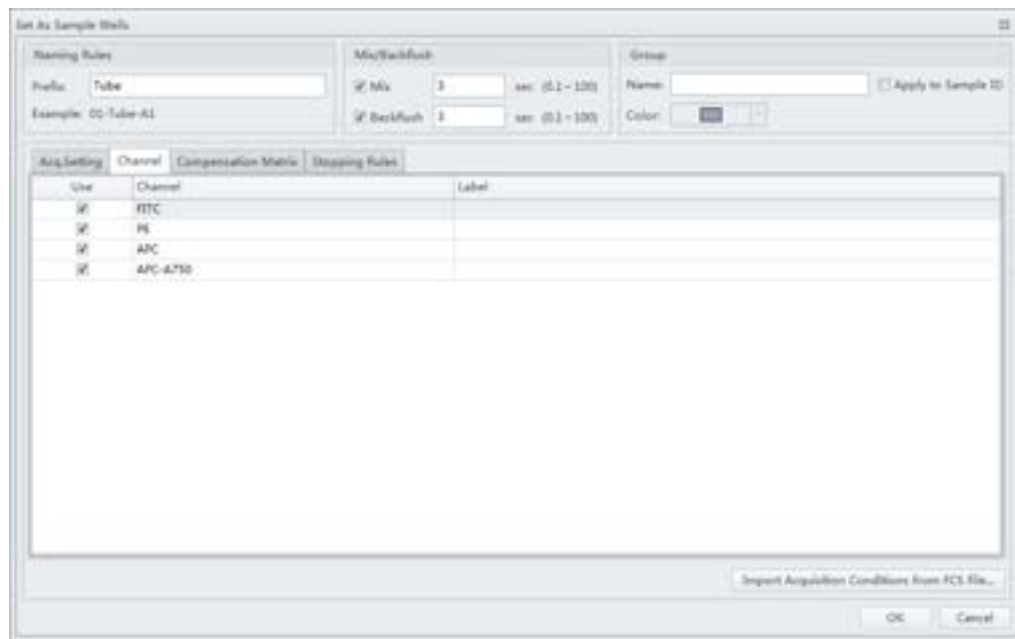

- 9 Set compensation under the Compensation Matrix tab. Refer to [CHAPTER 6, Compensation](#) for detailed instructions on setting compensation.

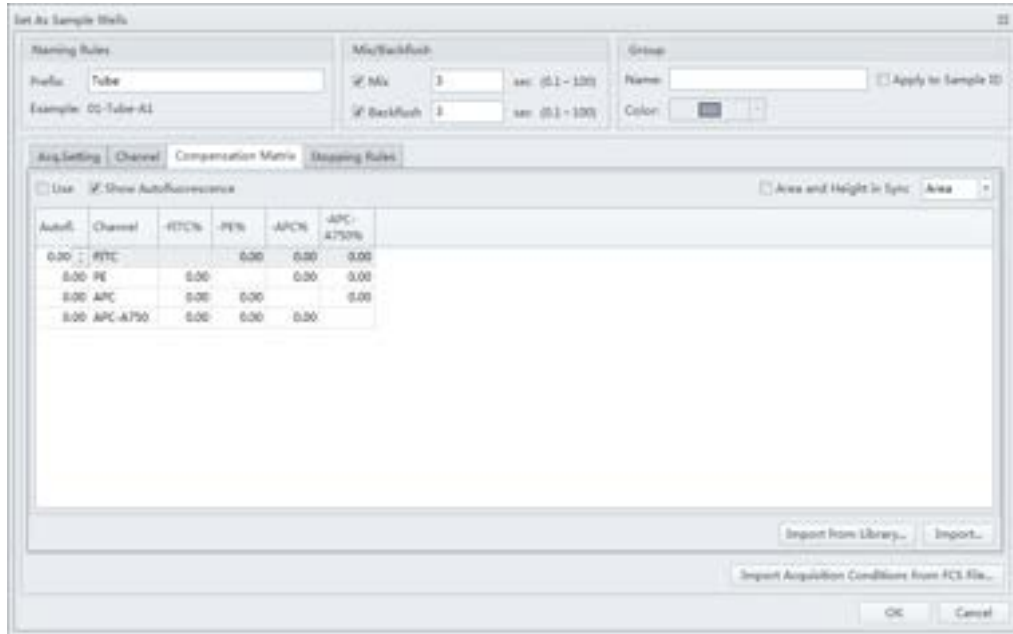

- 10 Select Events to record or time to record under the Stopping Rules tab.

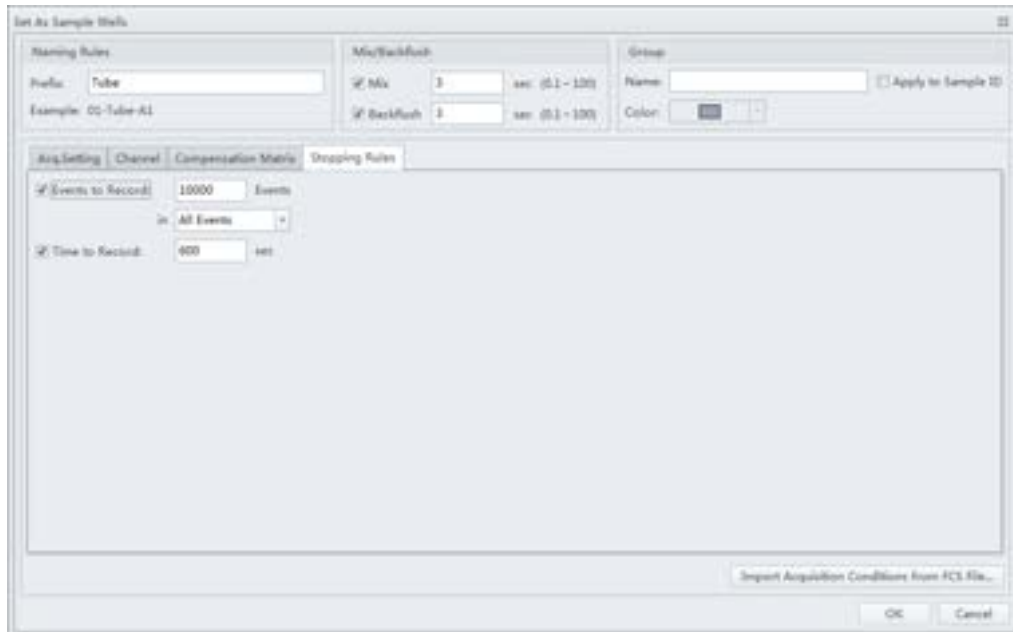

NOTE Beckman Coulter recommends setting an acquisition time limit, so the acquisition will not continue if the event limit cannot be reached.

11 Select **OK**.

Modifying Well Settings

If any well settings require modification, right click the sample well and select the setting to change.

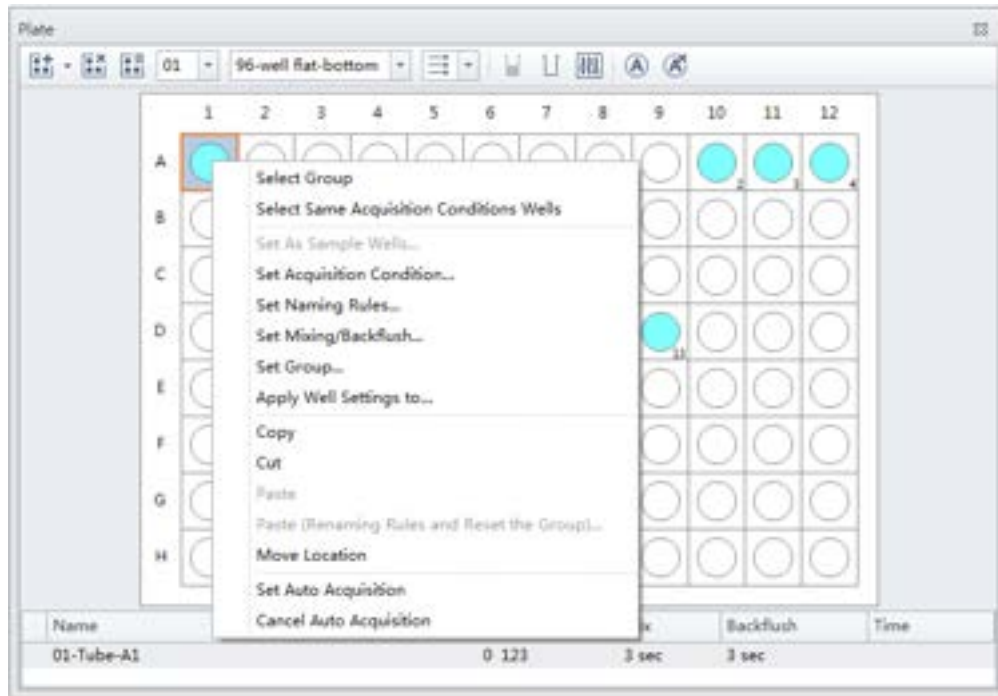

Applying Existing Well Settings to Additional Wells

- 1 Right click the well with the desired settings and select **Apply Well Settings to**. The Apply Well Settings of window appears.

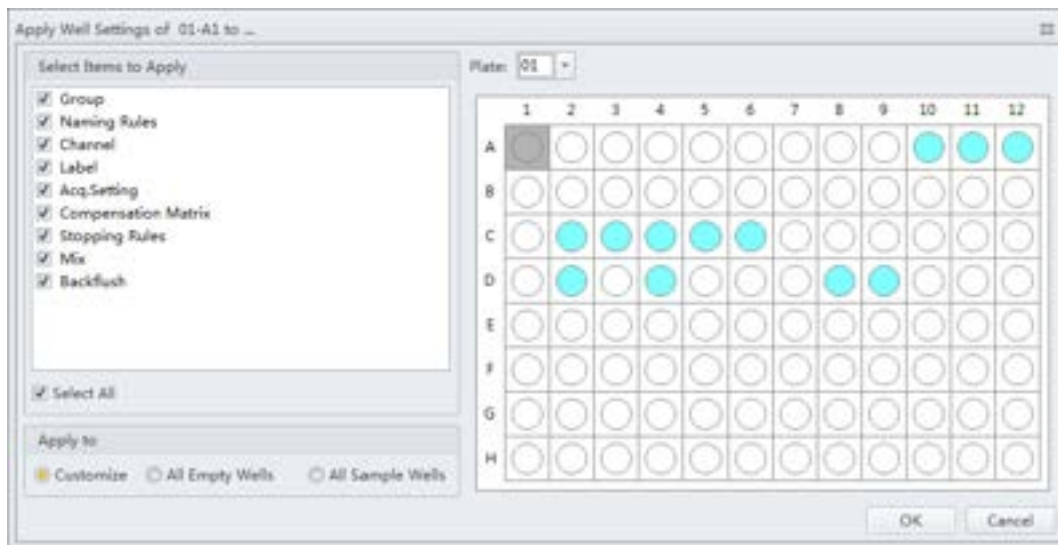

- 2 Select the wells to apply the well settings to.

NOTE Select the **Customize** option to select individual wells to apply the settings to. Select the **All Empty Wells** option to apply the settings to all remaining empty wells. Select the **All Sample Wells** option to apply the settings to all existing colored sample wells. You can not apply settings to wells that already contain data.

- 3 Checkmark which settings to apply from the Select Items to Apply section of the window.

NOTE

- If Group and Name Rule are selected, the settings can be applied to any wells, and empty wells will be set as sample wells after applied.
- If Group and Name Rule are not selected, the settings can only be applied to sample wells.

Copying, Cutting, and Pasting Wells

- 1 Left click and drag your mouse to highlight the desired wells or hold the Control key and select each desired well.

- 2 Right click and select **Copy** or **Cut**.

NOTE When **Copy** or **Cut** is selected, the well displays as follows:



-
- 3 Right click an empty well and select **Paste**.

NOTE The same number of wells will paste in the same orientation the wells were selected.

Moving the Location of a Well

- 1 Right click the desired well to move and select **Move location**.

NOTE When **Move location** is selected, the well displays as follows:



- 2 Select the new well location. The well will automatically move to the new selected location.
-

Running Samples

IMPORTANT Ensure the sample plate is loaded properly before acquiring the samples.

- 1 To run a single well:
 - a. Select the well in the Plate window.
 - b. Select **Run** to prompt the system to begin sample aspiration.

NOTE Acquisition settings can be adjusted during acquisition.

- c. Select **Record** to save the data.
- d. Select **Eject** to prompt the plate loader to eject.

To run a set of wells:

- a. Select the desired wells.

- b. Select  or right click and select **Auto Record** to set the selected wells for auto record. Number labels appear in the bottom right corner of each well set for auto record. Sample acquisition occurs in the order indicated by the numbers.

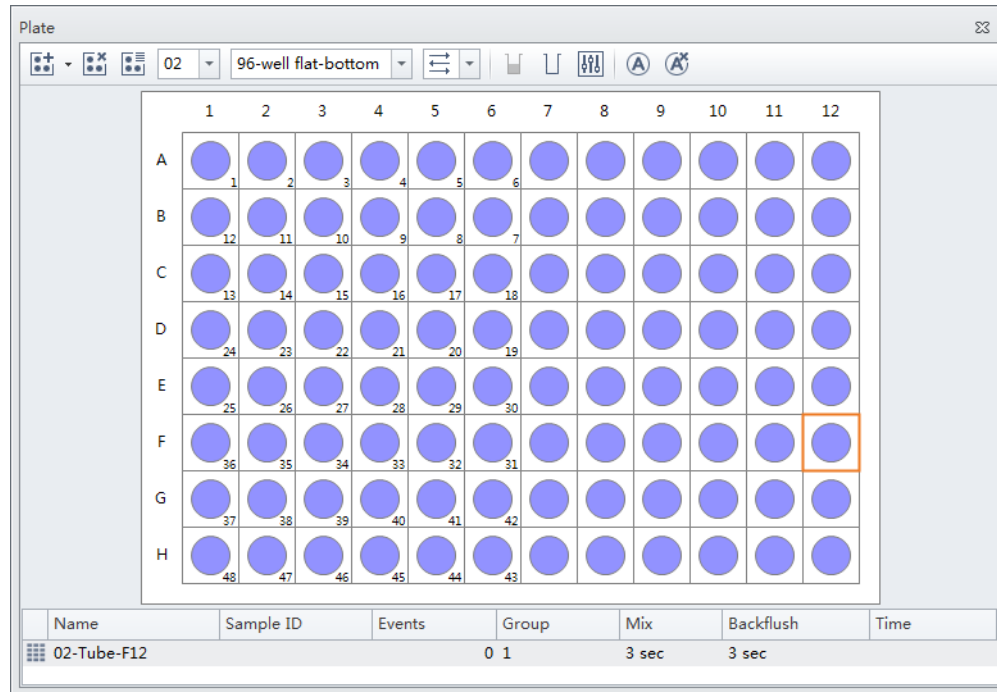

NOTE Select  to remove the auto record setting from the selected wells.

- 2 Select  **Auto Record** to begin sample acquisition.

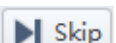
NOTE Select  **Skip** to skip the current well and move to the next well for acquisition.

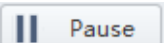
NOTE Select  **Pause** to pause acquisition. The software completes the current sample well acquisition and pauses when the current well is complete. The plate can be loaded and unloaded while the sample acquisition is paused.

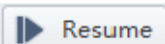
NOTE Select  **Resume** to continue the acquisition

Load Sample and Record Data

Before Running Samples

 CAUTION

Risk of erroneous results if the Cytometer has been idle for an extended period of time. Perform a prime if the system has been idle for an extended period of time (see [Priming the Flow Cell](#) in [CHAPTER 11, Replacement/Adjustment Procedures](#).)

- 1 Run the [Daily Startup](#) procedure.
- 2 Run the [Daily QC](#) procedure.
- 3 Create an experiment. Refer to [Creating an Experiment](#).
- 4 Verify mixer settings. Refer to [Changing Sample Mixing and Backflush Settings](#) in [CHAPTER 11, Replacement/Adjustment Procedures](#).
- 5 Ensure that there is sufficient space on your hard drive for sample processing and data acquisition.
- 6 Verify the detector configuration. Refer to [Verifying, Selecting, Editing, and Creating Detector Configuration](#).

Verifying, Selecting, Editing, and Creating Detector Configuration

 CAUTION

Risk of erroneous results. The system will read the selected **Detector Configuration** even if the optical filters do not match the selected **Detector Configuration**. You must verify the installed optical filters match the selected **Detector Configuration**.

- 1 Select **Detector Configuration** in the Cytometer menu to verify the correct detector configuration is selected. To change the configuration:
 - a. Select the desired configuration.

b. Select Set as Current.

A green checkmark appears in front of the selected configuration.

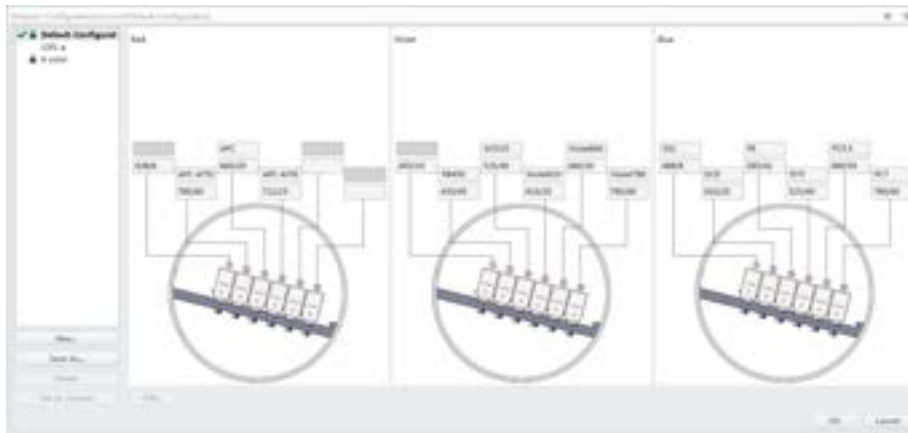

NOTE A configuration is locked when  appears to the left of a configuration. A configuration locks for two reasons:

- QC was run using the configuration.
- The compensation library contains data for the configuration.

Locked configurations can be deleted, but not edited.

2 Select **OK** to close the Detector Configuration screen.

3 Proceed to Step 4 if you need to edit the Detector Configuration settings, or skip to Step 5 if you need to create a new Detector Configuration, or skip to Step 12 if you need to delete a Detector configuration.

4 If a saved configuration requires changes, edit that configuration.

NOTE The factory configuration is in bold and cannot be edited.

a. Select the configuration, then select **Edit** to access the Edit Detector Configuration screen.

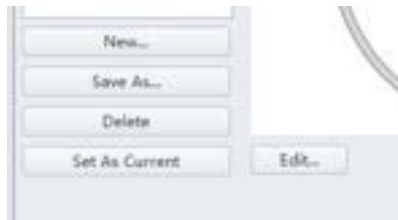

- b. Channels with a white background can be edited. Drag the names of the appropriate fluorescence channels and optical filters on the left to the correct channels.

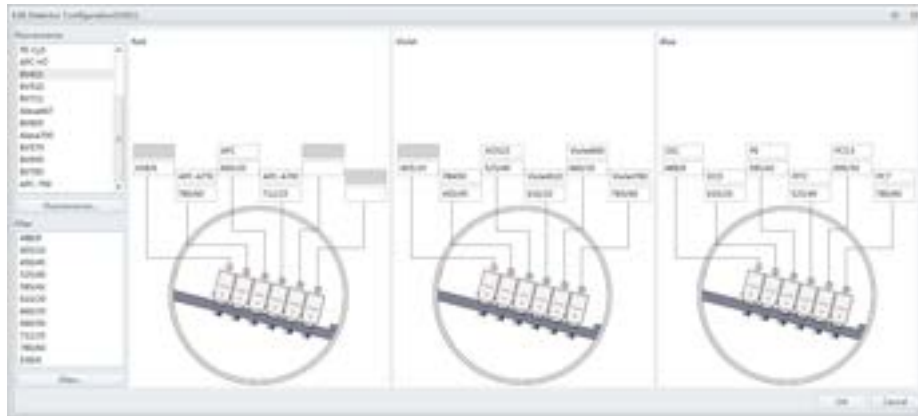

- c. Continue to Step 6.

5 If an appropriate configuration is not saved, create a new configuration.

- a. Select **Detector Configuration...** in the Cytometer menu.
- b. Select **New...** and name your configuration.
You can also select a previously saved configuration and select **Save As** to create a copy.
- c. Select **OK**.
- d. Ensure the new configuration is highlighted, then select **Edit**. The Edit Detector Configuration window appears.

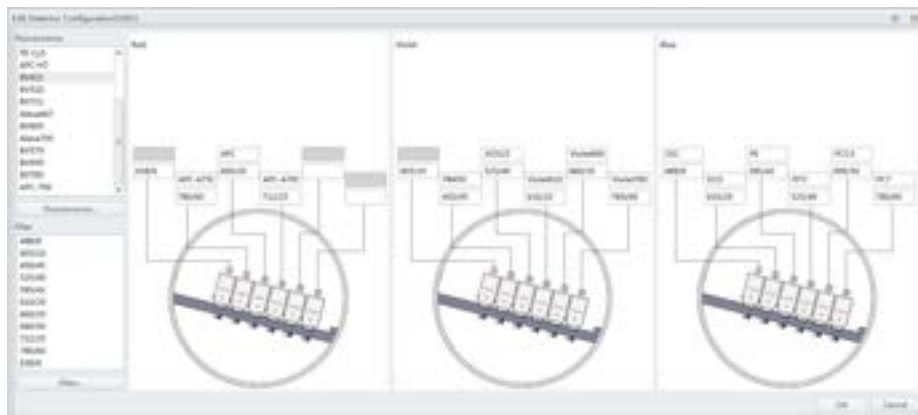

- e. Customize the new configuration. Channels with a white background can be edited. Drag the names of the appropriate fluorescence channels and optical filters on the left to the correct channels.
- f. Continue to Step 6.

-
- 6 If a required channel name or filter is not listed on the left, select **Fluorescence** or **Filter** to add or modify the channel name or the filter.

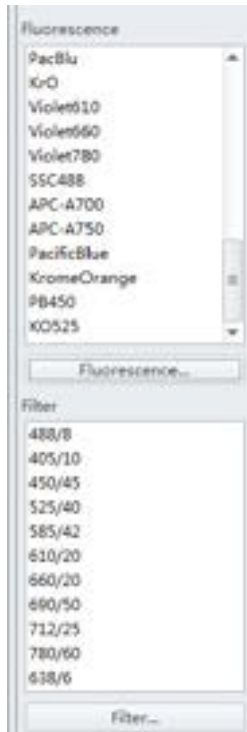

- 7 When finished, select **OK**.
-
- 8 Select the appropriate configuration.
-
- 9 Verify that the correct optical filters are installed in the Cytometer and match the newly created configuration.
-
- 10 Select **Set As Current**.
-
- 11 Select **OK**.

- 12 To delete a configuration created in error, select **Delete**. The following confirmation message appears. Select **OK**.

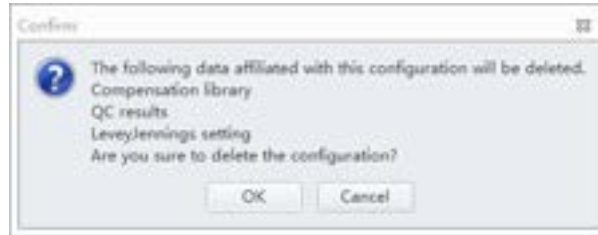

Setting Up Violet Side Scatter (VSSC) Channel

For micro particles, a VSSC option can be added to better separate side scatter signals from noise. Beckman Coulter recommends using this channel to detect particles smaller than 500 nm.

NOTE Since the total available channel numbers remain the same when the VSSC channel is used, the number of fluorescent channels in the violet WDM is reduced by 1 channel.

CAUTION

Risk of erroneous results. Beckman Coulter recommends using the VSSC channel to detect side scatter signals for particles smaller than 500 nm. VSSC could be too sensitive when large particles are being acquired. This could cause incorrect measurement for other channels in the Violet WDM. Switch back to the original detector configuration for particles larger than 5 µm. For particles larger than 5 µm, set the gain of the VSSC to 1 to increase the threshold and decrease the collection of sample noise.

- 1 Open the Violet WDM lid (see [Replacing the Optical Filter](#) in [CHAPTER 11, Replacement/Adjustment Procedures](#)) and remove the 405-nm filter, the 450-nm filter, and a third filter not required for the test, for example, the 780-nm filter.

NOTE Refer to [Table 1.1](#) to identify the WDM filter mount color codes.

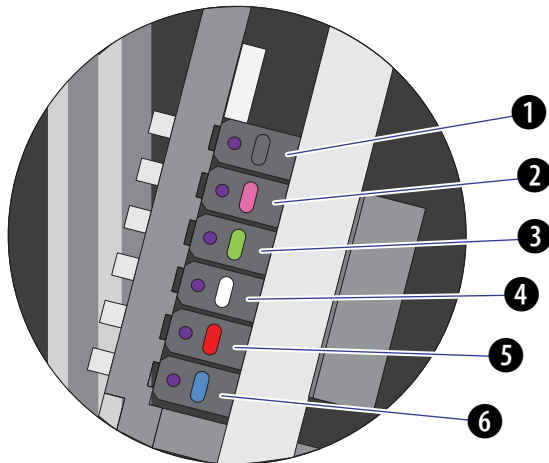

- | | |
|---------------|---------------|
| 1. Position 1 | 4. Position 4 |
| 2. Position 2 | 5. Position 5 |
| 3. Position 3 | 6. Position 6 |

NOTE The orientation for position 1 through 6 starts with position 1 located closest to the back of the Cytometer, and position 6 located closest to the front of the Cytometer.

- 2 Place the third filter in position 1, the 405-nm filter in position 2, and the 450-nm filter in position 3.

NOTE For the Violet WDM, Beckman Coulter recommends placing the filters in sequential order from the shortest wavelength to the longest wavelength in positions 2 to 6. Position 1 will always contain the unused filter.

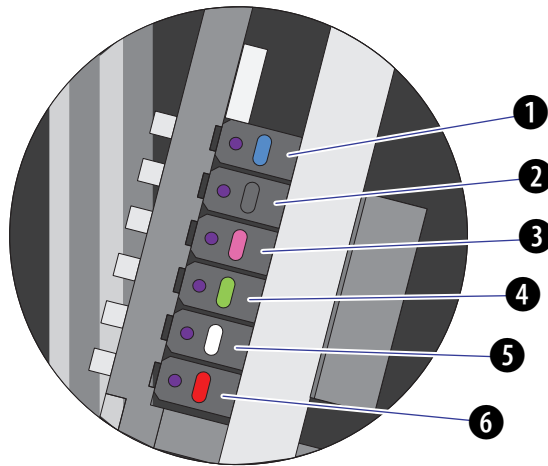

- | | |
|---------------|---------------|
| 1. Position 1 | 4. Position 4 |
| 2. Position 2 | 5. Position 5 |
| 3. Position 3 | 6. Position 6 |

- 3 Start the CytExpert software. Refer to [Opening the Software](#) in [CHAPTER 3, Daily Startup](#).

- 4 Select **Detector Configuration** from the Cytometer menu. The Detector Configuration window appears.

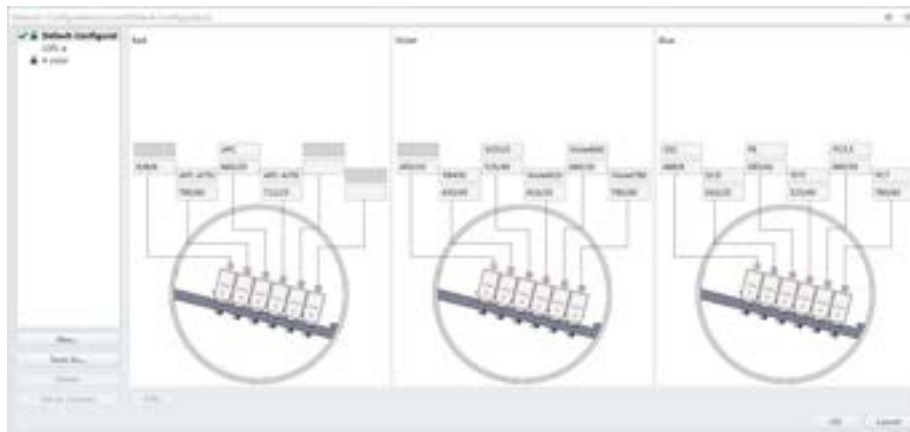

- 5 Select the Default Configuration and select **Save As**. The Configuration Save As window appears.



- 6 Name the new configuration VSSC and select **OK**.

- 7 Select the VSSC configuration and select **Edit**. The Edit Detector Configuration window appears.

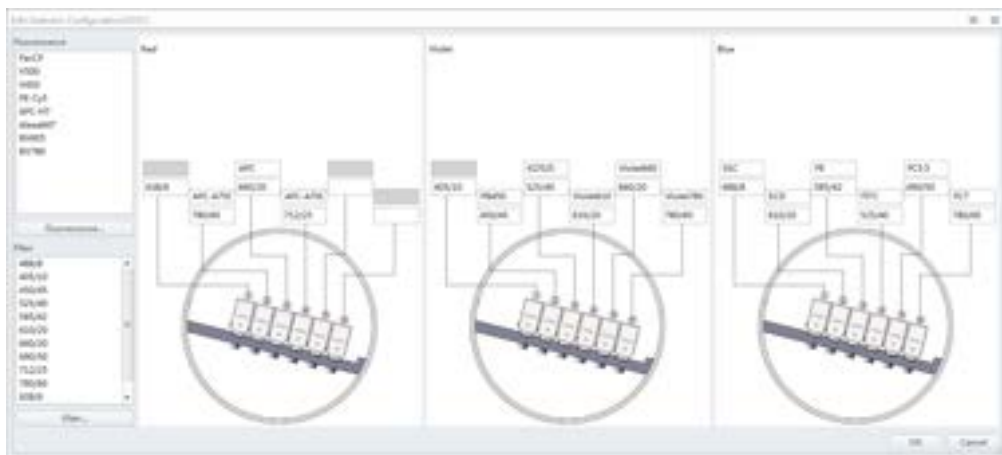

- 8 Change the filters and channel names according to the filter order in the violet WDM.

- 9 Right-click the VSSC channel, and select **Set SSC** to set it as the Violet SSC channel.

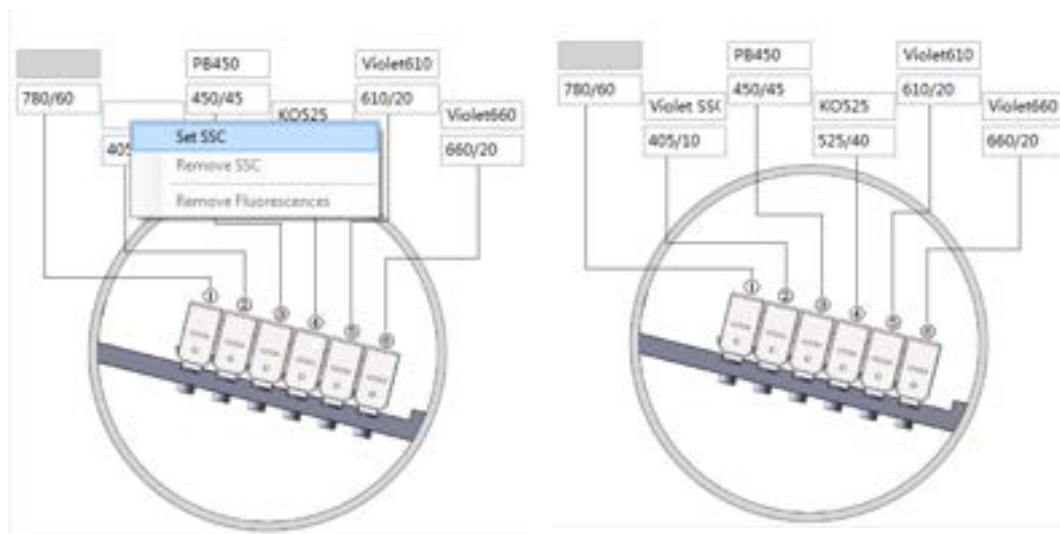

- 10 Select **OK** to save the changes and close the Edit Detector Configuration window.
- 11 Select **Set as Current**.
- 12 Select **OK** to save the changes and close the Detector Configuration window.
- 13 Create a new experiment using the VSSC configuration. Refer to [Creating an Experiment](#).

Sampling and Collecting Data

- 1 Select  from the Test Tube screen to create the new sample tube.
NOTE The first sample tube is already created by default.
- 2 Change the tube name if necessary. Refer to [Changing the Tube Name](#).
- 3 Mix the sample tube intended for testing.

- 4 Ensure that the sample tube holder is in the sample loading position (see [Figure 1.9](#)). If the sample tube holder is not in the sample loading position, select **Initialize**.

 **WARNING**

Risk of biohazardous contamination. When using 1.5-mL and/or 2-mL sample tubes, always cut the cap off and do not exceed 300- μ L sample volume. Running samples with a cap attached to the sample tube or with volumes exceeding 300- μ L can result in sample splashing.

- 5 Place the sample tube in the sample tube holder.
- 6 Select the desired acquisition parameters (Events/Time to Record and Sample Flow Rate) on the left side of the screen.

NOTE You can also push the load button on the front of the instrument to automatically start the run and record the data.

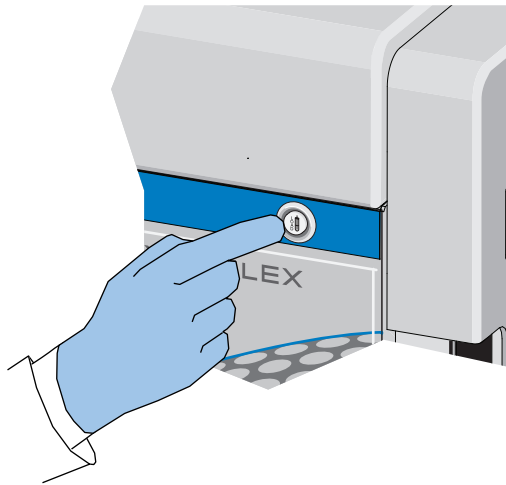

7 Select **Run** to load the sample.

NOTE When you select a tube that only contains acquired data, as indicated by the blue tube  in the test tube section of the screen, the following message appears:

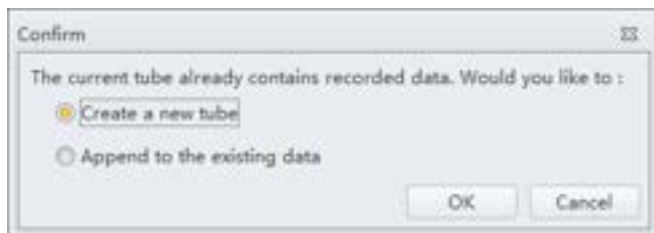

- **Create new tube.** Saves the current tube and creates an additional tube.
- **Overwrite existing data.** Overwrites the current tube data with new data.

8 View the plots and establish the gates. Refer to [Creating Plots and Gates](#). Adjust the gate and instrument settings as necessary. Refer to [Configuring Acquisition Settings](#).

9 Adjust the gain settings. Refer to [Adjusting the Gain](#).

10 Adjust the threshold settings. Refer to [Adjusting the Threshold](#).

11 Adjust the Acquisition conditions. Refer to [Setting Collection Conditions](#).

12 Select **Record** to save the data.

Wait for the saving process to finish. The sample tube holder returns to the sample loading position (see [Figure 1.9](#)).

NOTE When you select a tube that contains recorded data, as indicated by the green tube  in the test tube section of the screen, the following message appears:

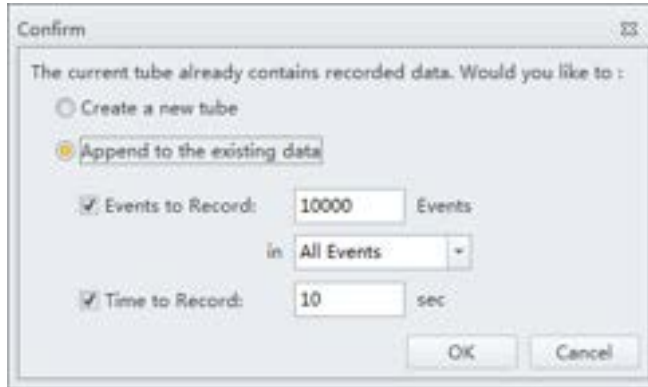

- **Create new tube.** Creates a new tube in the test tube section of the screen for the data.
- **Append data to existing data.** Adds new data to the existing data.

NOTE When you select a tube that only contains acquired data, as indicated by the blue tube  in the test tube section of the screen, the following message appears:

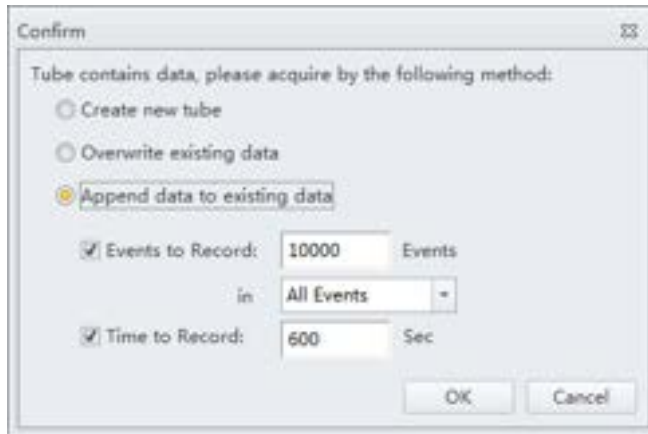

- **Create new tube.** Creates a new tube in the test tube section of the screen for the data.
- **Overwrite existing data.** Overwrites the current tube data with new data.
- **Append data to existing data.** Adds new data to the existing data.

13 Repeat steps 1-12 until all sample tube data required for testing has been collected.

NOTE If the rate suddenly appears to drop, check to see if the sample has run dry or the sample probe is clogged. Any time the sample probe becomes clogged, immediately select **Stop** to unload the sample. Then select **Backflush** to clean the sample probe. Refer to [Daily Clean](#) in [CHAPTER 10, Cleaning Procedures](#), to flush out the sample probe. If you are still unable to clear the sample probe, contact your Beckman Coulter Representative.

Configuring Acquisition Settings

Changing the Tube Name

To change the name of a new sample tube or the sample ID, right-click the tube name or the sample ID name in the Tube section of the screen and select **Edit Name** or simply double-click the sample tube or sample ID name.

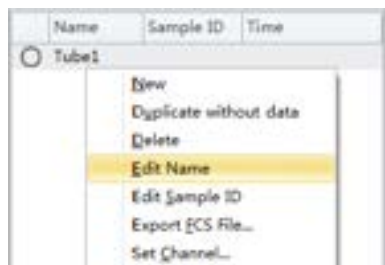

Setting the Channel and Label

1 Select **Set Channel** in the Settings menu. The Set Channel window appears.

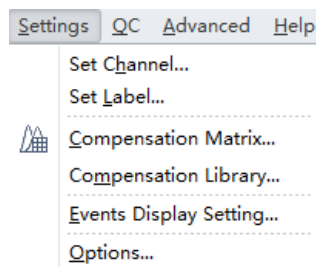

- 2 In the Set Channel window, modify which channels are used and how they are displayed.
 - a. Select the channel signal check box, then you can add the reagent name in the Label column. The information you add appears in the corresponding axis of the relevant plot in the plot area. Unselected channel signals are not stored in the data file.

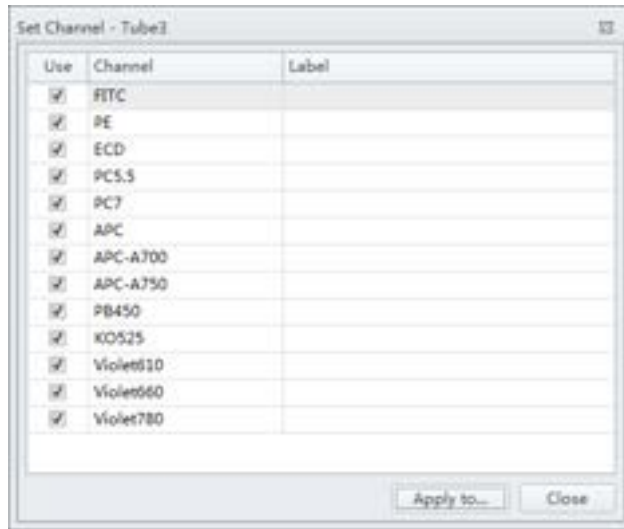

- b. Select **Apply to**. The Apply Channel Setting window appears.

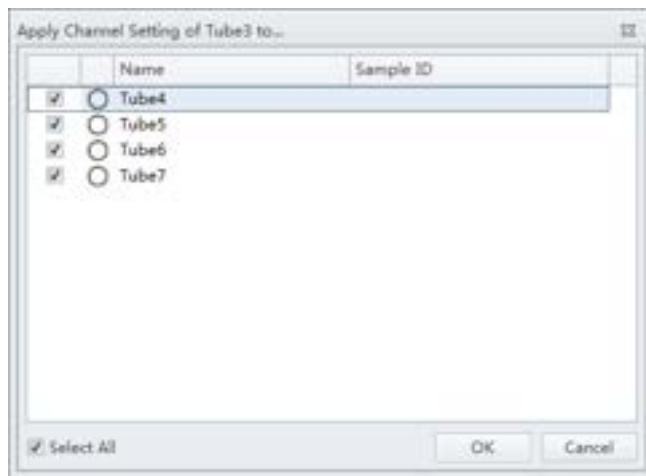

- c. Select the the tubes to apply the channel settings to and select **OK**.

- d. If you only need to modify the label name, select **Set Label** in the Settings menu to make the required changes. The Set Label screen appears. The Set Label screen does not allow you to select which channels to use, but it does allow you to apply the modified label to all the sample tubes.

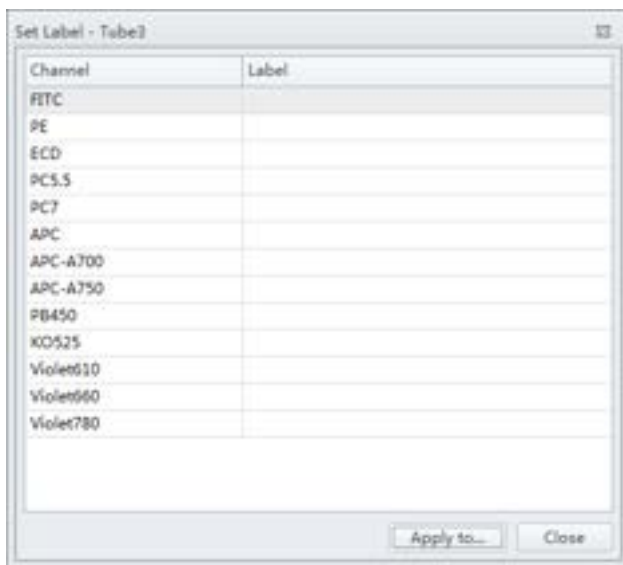



- e. Select **Apply to**. The Apply Label Setting window appears.



- f. Select the tubes to apply the label settings to and select **OK**.

Creating Plots and Gates

- 1 Use the plotting controls (see [Figure 2.1](#)) in the plot area to create plots and gates and to generate graphs as shown.

Use the   icons to generate histograms, dot plots, density plots, pseudocolor plots, and contour plot.

The experiment uses scatter plots, histograms, polygon gating, four-quadrant gating, and line-segment gating.

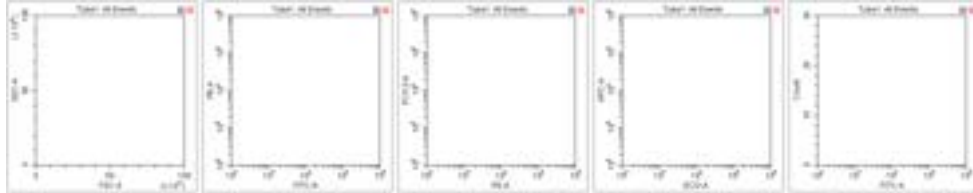

- a. After selecting a plot, click and drag the mouse to adjust the position and select and drag the sizing handles at the edge of the graph to adjust the size of the graph.

- b. Select an axis name to change which channel is displayed. An “A” after the channel name indicates signal pulse area, while an “H” indicates height. The default setting is "A".

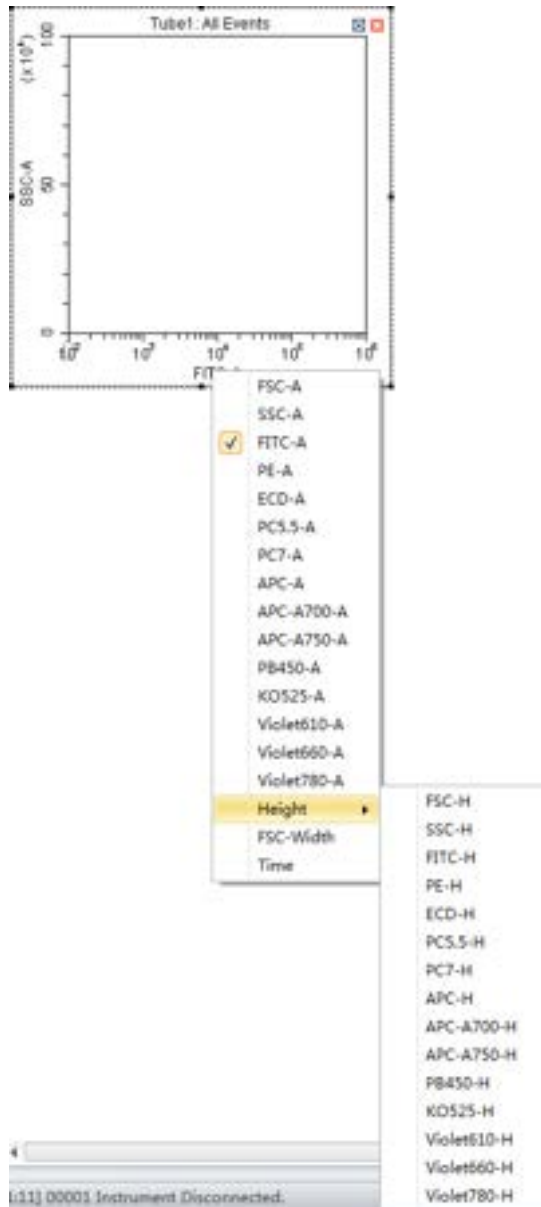

NOTE To modify the default settings, select **Options** in the Settings menu. The Options window appears. Select **Plot** on the left side of the Options window. Under the Signal section of the window, change the Main Channel default by selecting the **Height** or **Area**.

- c. Signal width can be used to differentiate somatic cell adhesion. If necessary, select

 Acq. Setting... to open the Acq. Setting window.

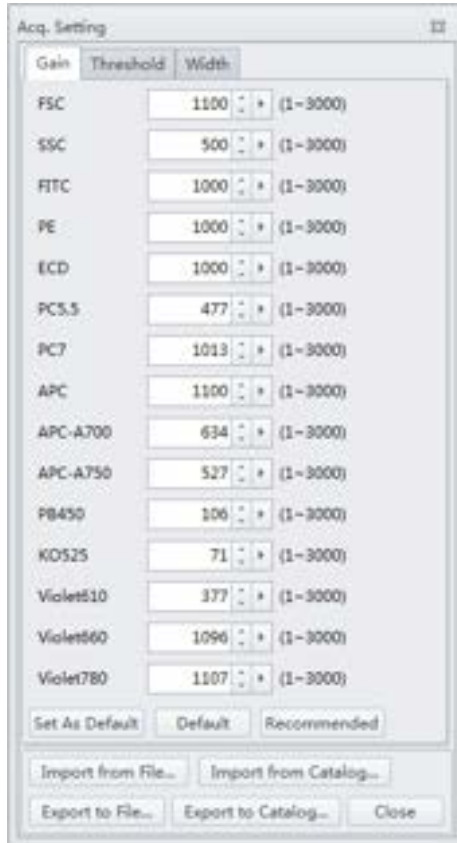

- d. Select the **Width** tab, and select a channel with the required signal width.



- e. Plot properties can be configured to display axes in logarithmic, Log-Linear, or linear format. To do so:
- 1) Right-click the plot and select **Property** from the drop-down menu. The Plot Property screen appears.



- 2) Select whether to display the axes in logarithmic or linear format for both the X-axis and Y-axis. Enter a value for log-linear coefficient if the log-linear view is desired.
- 3) Select **Close**.

Or

Select the logarithmic axis on the plot. The slider appears. Drag the slider along the axis to change the log-linear coefficient and view events that are not shown, including events with negative values.

NOTE The log-linear slider is also available during data acquisition.

NOTE To reset the axis back to logarithmic, right-click on the axis and select **Property**. Select **X axis Default** or **Y axis Default** to reset the axis.

Histogram with logarithmic X-axis

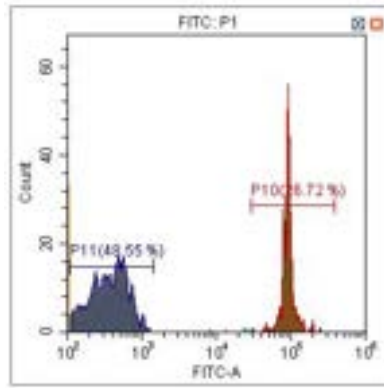

Histogram with log-linear X-axis

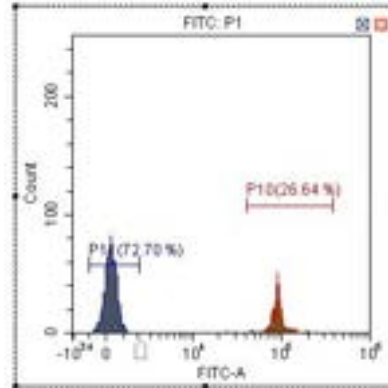

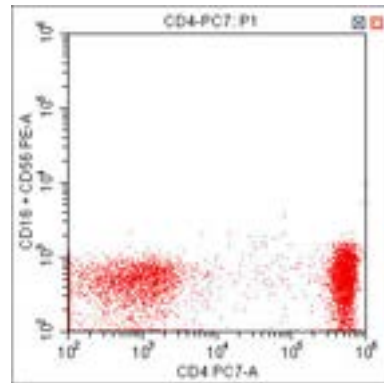

Dot plot with logarithmic X-axis

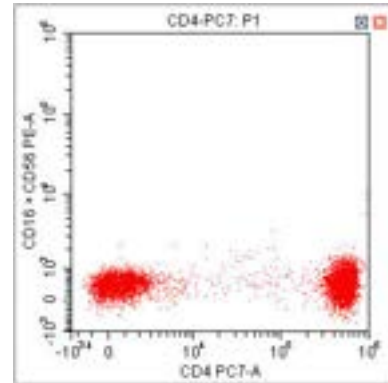

Dot plot with log-linear X-axis



- f. You can adjust axis ranges using the axis display controls located at the top of the screen.
- Select  , to zoom-in and define which area of a plot to enlarge. The selected area can be magnified to fill the entire graph. By selecting the zoom-out function, you can click on the graph and restore the plot to its original appearance before magnification.

- Select  to shift the axes. The mouse pointer appears as a hand. It allows you to drag the graph to reveal the axis segment you need.

-  Pan: Modifies the axis display range dimensions when panning both axes. When the pan control is selected, you can right-click the graph and select which axis you need to adjust when dragging. You can also pan directly to the default axis range.

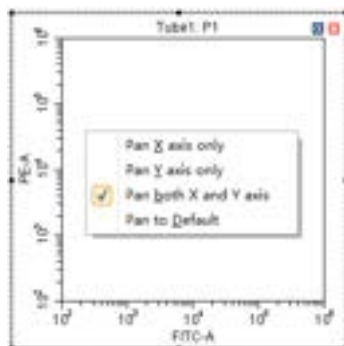

-  Single side pan: Modifies the axis display range dimensions when panning one axis.

NOTE Only the low end of the axis can be adjusted by the single side pan tool.

- Double-click the border area of the plot to open the Plot Property window, or right-click the plot, then select **Property** to open the same Plot Property window.
- In the Plot Property window, manually enter the minimum and maximum display values for the X- and Y-axes. You can also select **Fit With Sample** to let the software automatically adjust the lower limit according to the signal and perform the corresponding log-linear transformation. The X- and Y-axes **Default** settings are the default parameters. The default parameters are 100-1,000,000.

NOTE Select **Fit With Sample** to identify the signal's lower limit, adjusting automatically as warranted. Selecting this item is recommended whenever the signal appears to be relatively low.

NOTE Select **Auto** to automatically sets the upper and lower display limits of the axes based on the data already collected.

NOTE Select **Options** in the Settings menu, then select **Plot** to modify the default setting of the axis range under the Axis Default Setting section of the window.

- 2 To create gates, use the  control buttons or right-click the plot and select the gate type required. Gates can be set according to different requirements to differentiate cell populations.

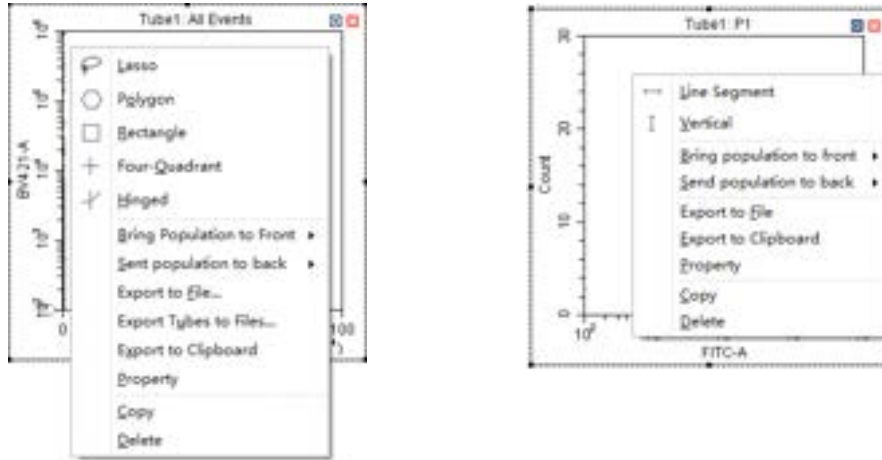

NOTE A newly created gate becomes a subset of the plot where it appears. The relationship between parent and progeny/daughter gates can be changed when a displayed gate is subsequently modified.

The position of the same gate in different sample tubes may vary. To change the position of a gate and apply the change to all sample tubes accordingly, you can right-click the gate and select **Apply to All Tubes**.

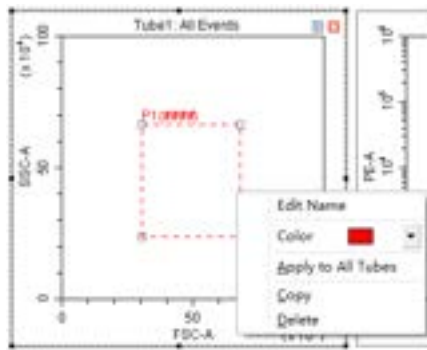

- 3 Select the gates to display.

- a. Select the heading area of the plot, select the parent population/gate to display in the plot from the drop-down menu. The selected parent gate appears in the tab area of the plot.

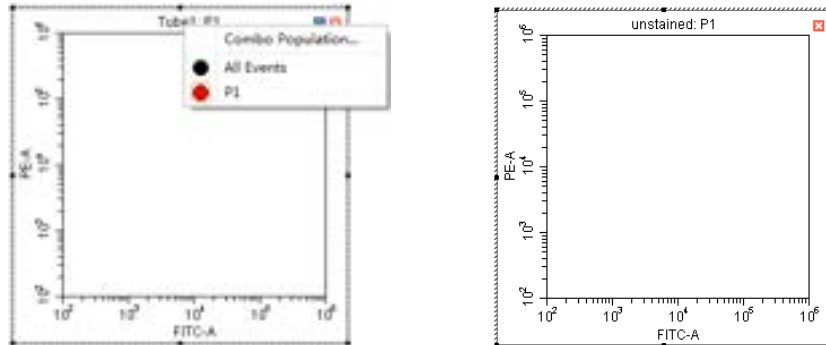

- b. If necessary, you can select the **Combo Population** option from the drop-down menu to create a combination gate, using the boolean relationships “and”, “or”, and “not” to produce a new gate. You can also select the population color or change the gate name.



- “And” indicates that all selections must be satisfied. For example, “P1 and P2” means that the data for the newly added gate represent the intersection of P1 and P2.
- “Or” indicates that only one of the selections need be satisfied. For example, “P1 or P2” means that the data for the newly added gate represent the union of P1 and P2.
- “Not” indicates exclusion from the selection. For example, “Not P1” means that the data for the newly added gate represent the events that are not part of P1.

NOTE For plots where a gate has been added to the plot, you cannot select to display the data of this gate or create a compound gate incorporating gates already added to said plot.

- 4 Select  to display the population hierarchy.

The Population Hierarchy function allows you to view how gates rank in relation to one another. To change the display color, double-click the default color and select the desired color from the drop-down color palette. To change the name of each gate, double-click the name of the desired gate. By hovering your mouse pointer over a combo population whose display name has just been changed, you can view its corresponding boolean logical operation.

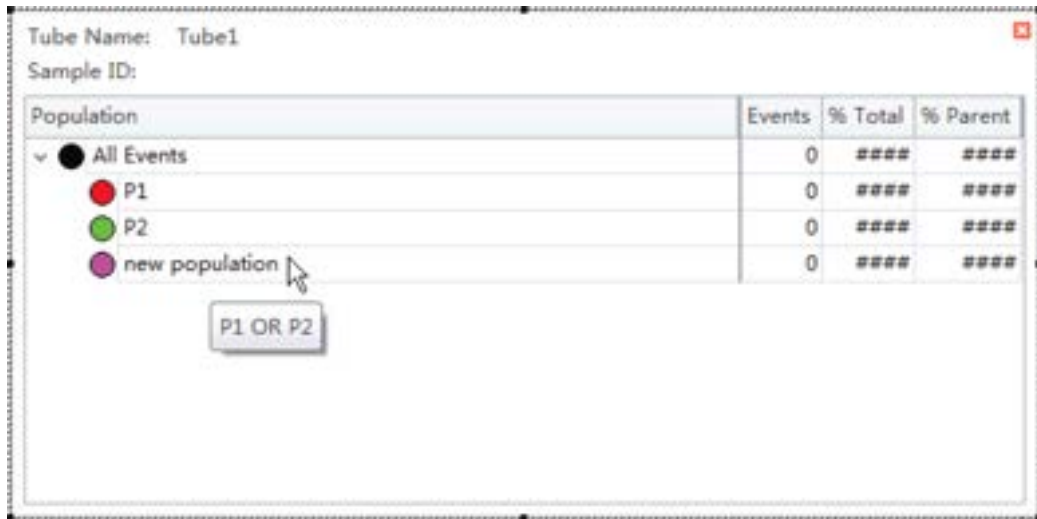

Population	Events	% Total	% Parent
▼ ● All Events	0	####	####
● P1	0	####	####
● P2	0	####	####
● new population	0	####	####

Adjusting the Gain

While the instrument is in use, the signal value can be increased or decreased by adjusting the instrument's gain configuration.

- 1 Select  on the left side of the screen. The Acq. Setting window appears.

- 2 Select the **Gain** tab in the Acq. Setting window.

Select or edit the instrument's default gain settings using one of the following methods:

- Edit the gain settings and select **Set as Default** to create a new default setting.
- Select **Default** to return to your saved default settings.
- Select **Recommended** to use the instrument's QC settings.

NOTE In cases where you do not specify your own default parameters, the recommended settings and default settings are identical.

- Adjust the gain setting of each channel under the Gain tab in the Acq. Setting window. Raising the gain increases the signal. Lowering the gain reduces the signal.



Another option is to use the **Gain Control** button  on the toolbar in the graphic control area to adjust the gain values for cell population data to their desired levels, directly on the plots where the data appears during data collection.



NOTE Gain adjustments have a predefined range between 1 and 3,000.

- If necessary, change the coordinate display range and the plot type.

Adjusting the Threshold

By adjusting the threshold, the user can remove unnecessary signal noise to ensure that most of the data collected consists of desired signal data. After the threshold settings have been configured for a given channel, the acquisition of data from this channel will only be triggered by signals that

exceed the established threshold. Threshold settings have considerable bearing on whether the appropriate events can be acquired.

- 1 Create a plot to view the channels where the threshold will occur. Generally, a bivariate plot showing FSC and SSC is used.

NOTE Threshold can be defined for any of the fluorescence channels.

- 2 Select  Acq. Setting... on the left side of the screen.

- 3 Select the **Threshold** tab in the Acq. Setting window.

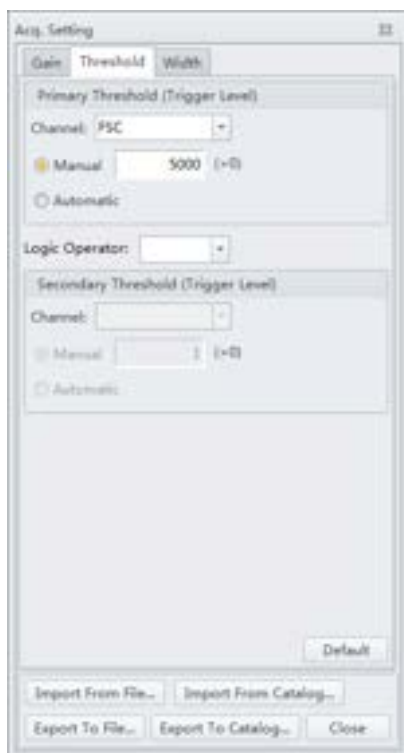

- 4 Set the desired threshold using one of the following methods:
 - Choose the channel that is used for setting the threshold. Manually enter the threshold value in the Threshold tab.

NOTE For dual-parameter plots, you can right-click the plot and select both parameters if desired. Then, select the desired threshold boundary for the second parameter.

- Select **Automatic** in the Primary Threshold Trigger Level section of the Acq. Setting screen to seek the target signal based on the background signal. It can quickly help find the target population if the signal-to-noise ratio (SNR) of the channel is comparatively good. The threshold can be set to either “H” (signal height) or “A” (signal area).

NOTE The automatic threshold value is based on the relative signal difference. When adjusting gain, you do not need to update the threshold settings. For channels with a low SNR or an excessively impure signal, manually setting the threshold parameters is recommended.

Moreover, “and” as well as “or” can be applied to as many as two channels, so as to allow these boolean logical operators to be used in setting the threshold value.

- “and”: Data is displayed and collected only when two threshold conditions are met simultaneously.
 - “or”: Data is displayed and collected when at least one of two threshold conditions are met.
- Select  from the plot control area. Move your mouse pointer to the desired threshold position in the desired plot and select once.

5 Select **Close** to start using the new threshold settings.

Setting Collection Conditions

- 1** Check mark the conditions required to set the necessary stop count events on the left side of the Acquisition screen.

Two stop count collection conditions are available for sample recording:

- **Events to Record.** Used to set the number of events to record in the specified population.
- **Time to Record.** Used to set the collection time duration in seconds.

For example, if the event to record is set to record 1,000 P1 events, the software automatically stops recording when P1 events reach 1,000 events. However, the software saves all data acquired, including events outside of P1, when 1,000 P1 events is reached. You can also specify the time to store if necessary. When multiple acquisition conditions are established, any one of these conditions stops the collection process.

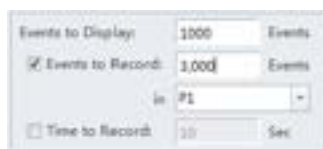

- 2 Select **Record** and wait for the software to complete collecting the data, at which time the sample tube holder returns to the sample loading position (see [Figure 1.9](#)).



- 3 If you made changes to the data acquisition conditions and need to apply these changes to an established sample tube, right-click the sample tube and select **Apply Acq. Settings To**, to apply the conditions accordingly.

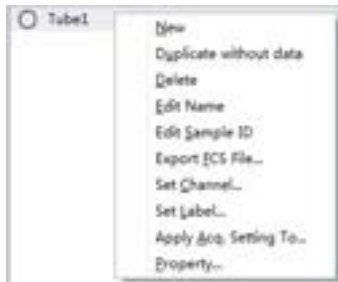

Setting Customized Parameters

Set custom parameter to create fluorescence calculations.

- 1 Select **Set Customized Parameter** from the Settings menu. Or, right click a test tube from the test tube menu and select **Set Customized Parameter**. The Set Customized Parameter window appears.



- 2 Enter a name for the parameter in the Name section.
- 3 Select the parameters for calculation in the Parameter dropdowns.

- 4 Select the equation operations from the Oper dropdown menu.
The new parameter name is displayed in the list of parameters and statistic items.

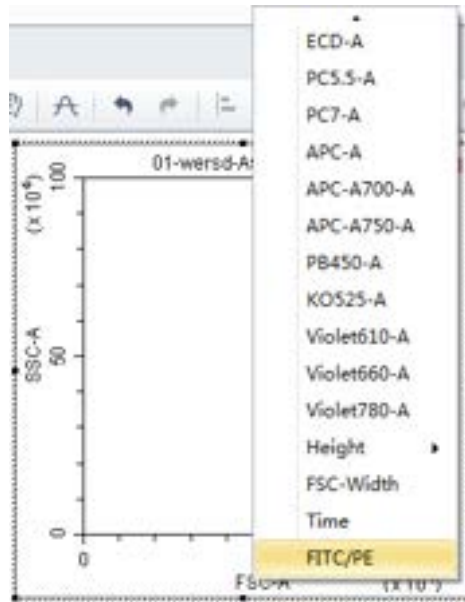

Setting Custom Statistics

Set custom statistics to create calculations based on populations of interest.

- 1 Right click the the statistics table and select **Statistics Setting**. The Statistics Setting window appears.

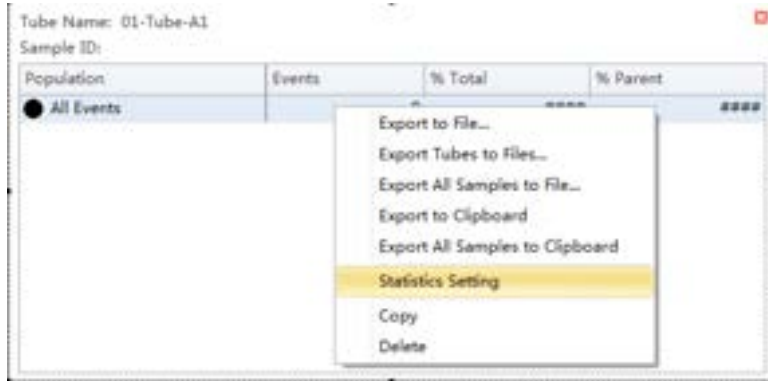

- 2 Select **Expression**.
- 3 Select **Edit**. The Expression window appears.

- 4 Enter the expression name in the Name section and enter the expression using the equation buttons.

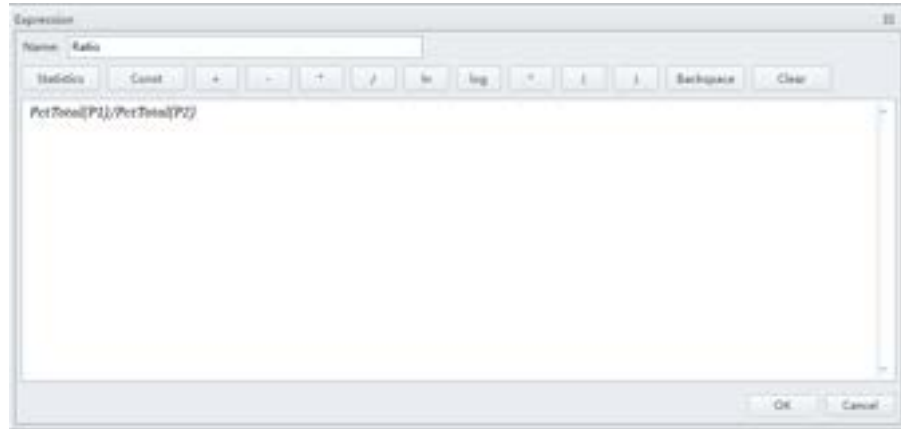

- 5 Select **OK**.

NOTE The equation populates in the Statistics Setting window under the Expression selection.



Analyzing and Exporting Data

- 1 Select the sample tube to be analyzed.
- 2 Establish new gates or adjust the position of existing gates. Refer to [Creating Plots and Gates](#).

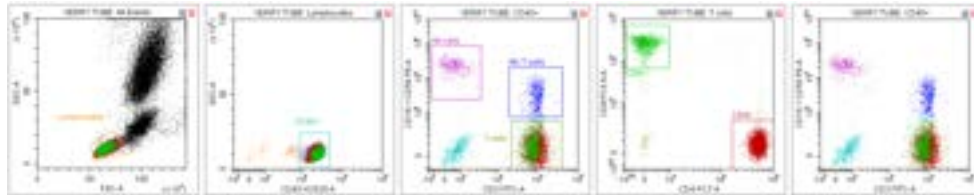

NOTE Changing a gate's position does not affect the positions of other gates already established on a given sample tube. Each test tube individually records the positions of its associated gates. If you need to make a change that concerns all the tubes, you must select the gate, then right-click the correctly positioned gate and select **Apply to All Tubes**.

- 3 Select . The Gate Hierarchy screen appears.
- 4 Check the relationship between the parent and daughter gates in the Gate Hierarchy window.

NOTE Newly added gates become subsets of populations displayed in plots with existing gates. Name and display color can be modified. Right-click directly on a gate plot to change the name and color.

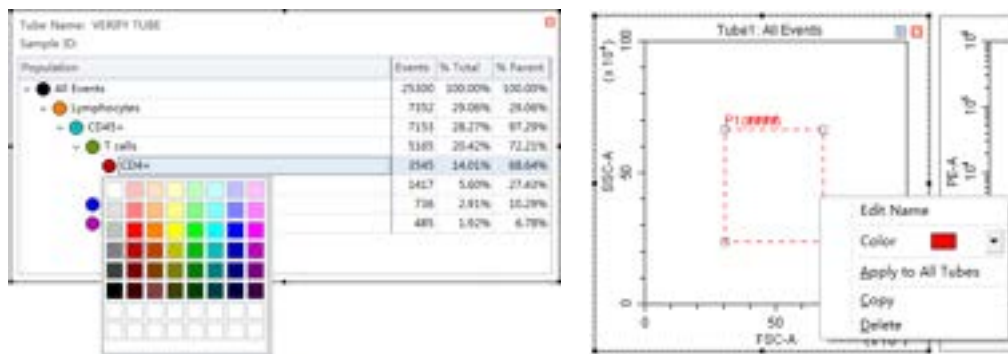

- Right-click the plot and select **Bring population to front** to make the display color of the specified gate appear in front of all other colors, or select **Send population to back** to hide the display color of the specified gate behind all other colors.

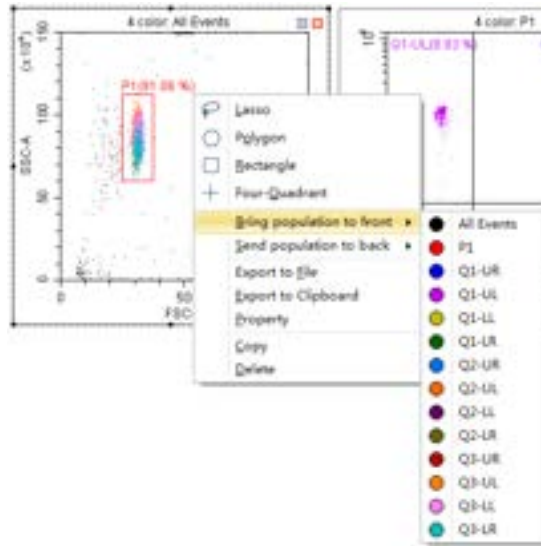

- Select  in the plot area to generate a statistical table.

- Right-click the table and select **Statistics Setting** to modify the settings of the statistics display parameters. The Statistics Setting window appears.

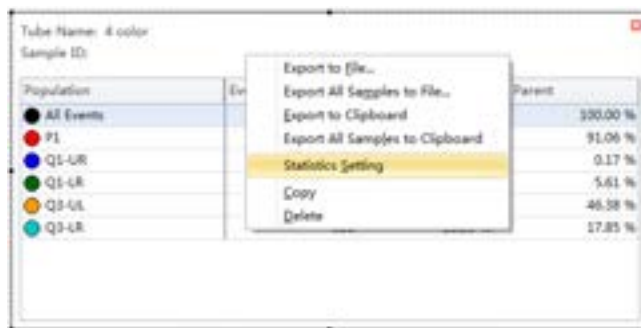

The Statistics Setting window allows you to change the display of the header, statistical elements and cell populations included.

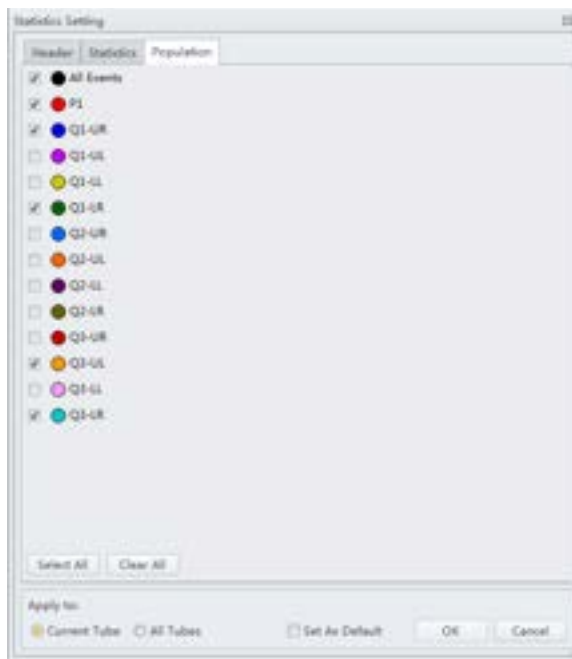

The final generated plots appear as below.

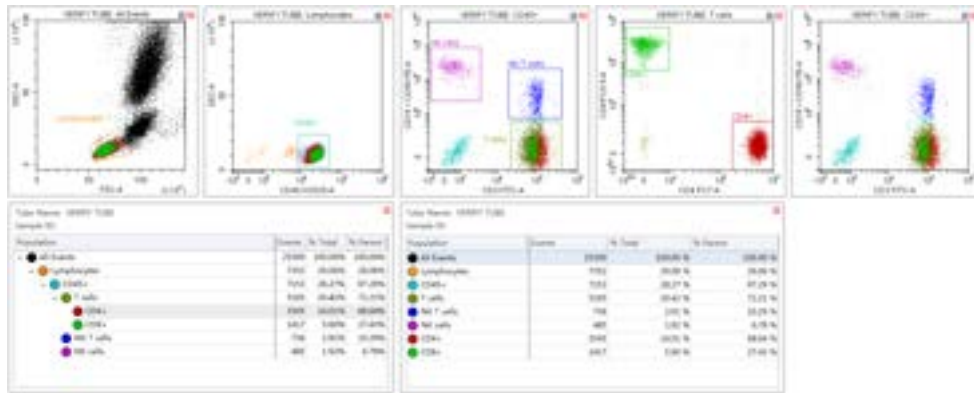

- Right-click a plot and select **Export to Clipboard** or **Export to File** from the drop-down menu to select an image to export.

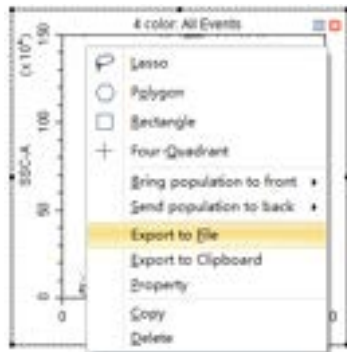

- Export to Clipboard** copies the plot to the clipboard, allowing you to paste it directly into documents in common file formats.

NOTE Multiple plots can only be copied and pasted into Microsoft® Word. If a single plot is copied, this can be pasted into both Microsoft® Word or Microsoft® PowerPoint.
- Export to File** saves the plot as an image file.

NOTE **Export to File** can export plots in two selectable file formats. BMP bitmap format and EMF vector format.

- 9 To export statistics, right-click a statistical table to select any one of the available export options.

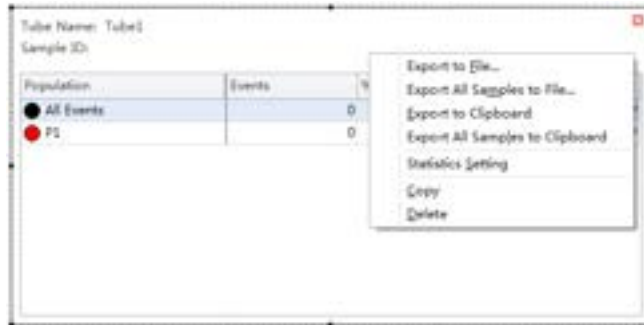

- **Export to File** exports individual tube statistics as a single CSV file.
- **Export All Samples to File** exports all tube statistics as a single CSV file.
- **Export to Clipboard** copies the statistics of the samples to the clipboard, allowing you to paste them directly into a Microsoft® Excel file or other file formats.
- **Export All Samples to Clipboard** assembles the statistics for all the sample tubes of an experiment and copies them together to the clipboard. From there they can be pasted as a group into a Microsoft® Excel file or other file formats.
- **Copy** converts a statistical table into an image format that can be pasted into documents.

- 10 Export the FCS file if necessary. Refer to [Exporting FCS Files](#).

NOTE Ensure that any storage devices used with the instrument are free from viruses. To guard against data loss, Beckman Coulter recommends backing up data on a frequent and regular basis. Beckman Coulter is not liable for any loss of data resulting from computer viruses or damage to hardware.

Exporting FCS Files

Exporting Single Tube Files

- 1 Right click the desired tube from the test tube section of the screen and select **Export FCS File**. The Export FCS File window appears.

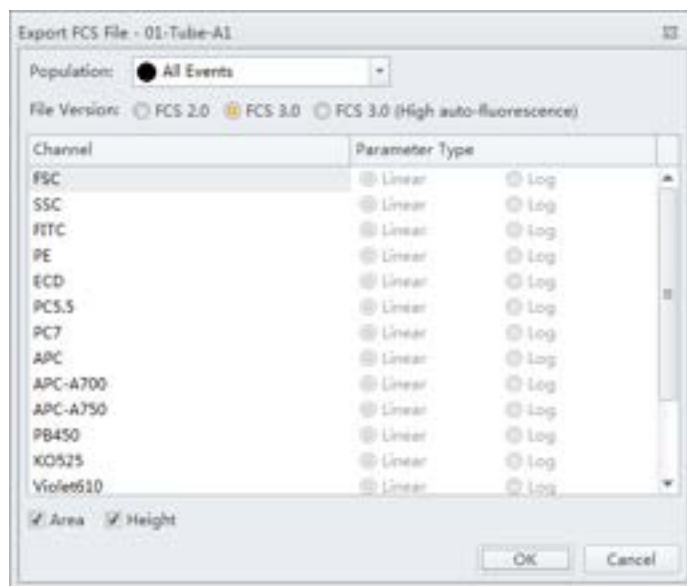
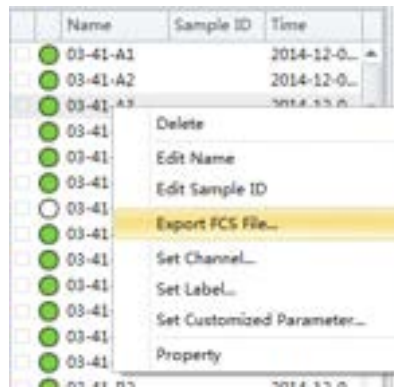

- 2 Select the population from the Population dropdown menu.
- 3 Select either **Area** or **Height**.

- 4 Select the FCS format next to File Version.

NOTE The default setting is FCS 3.0. If FCS 2.0 is selected, select the parameter type (linear or log) from the parameter type section of the window.

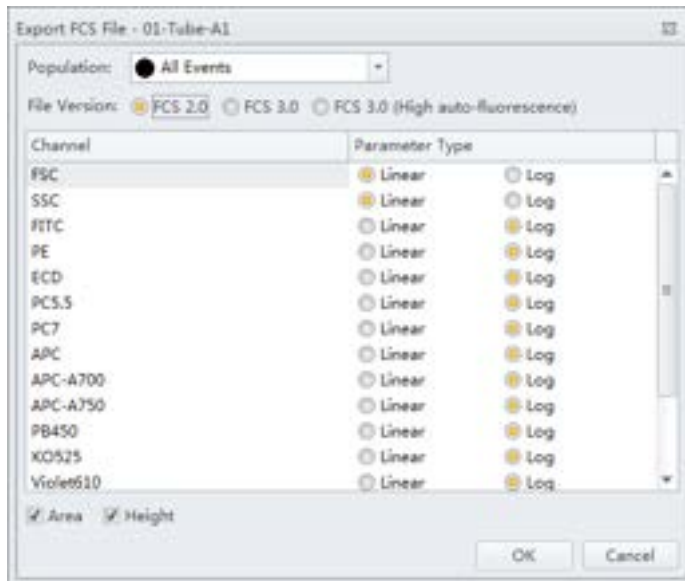

NOTE If high auto-fluorescence vector values are present, the data is displayed differently in third party software packages than in CytExpert. Use the FCS 3.0 (High auto-fluorescence) option if your file has high auto-fluorescence vector values. Auto-fluorescence values are added for the FCS 3.0 (High auto-fluorescence) option to accommodate the use of third party software. Since both FCS 3.0 options have the same .fcs file extension, ensure that you save the FCS 3.0 (High auto-fluorescence) files to a different folder than the FCS 3.0 files.

- 5 Select the path to save the FCS file to from the Path section of the window.

- 6 Select **Next** to export the file.

Exporting Multiple FCS Files

- 1 Select **Export FCS File** from the File menu. The Export FCS File window appears.

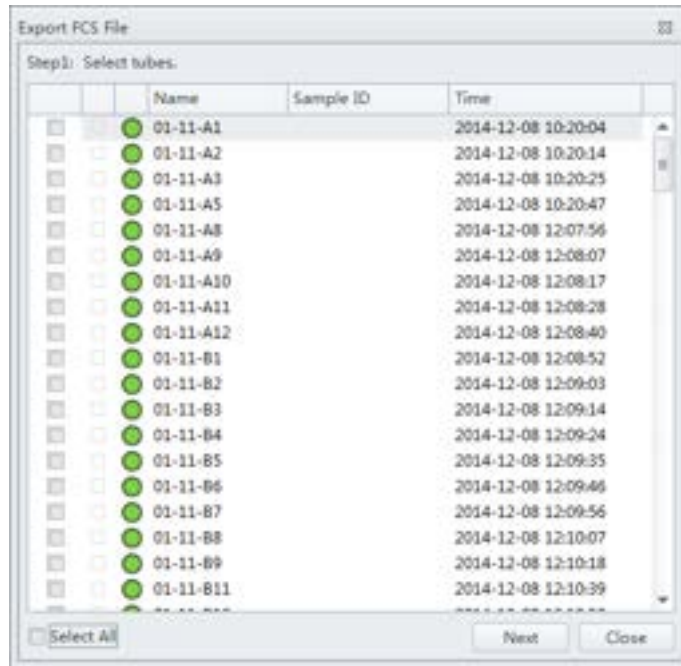

- 2 Select the tubes to export.
 - 3 Repeat Steps 2-6 from [Exporting Single Tube Files](#).
-

Exporting Plots or the Statistics Table of Multiple Tubes as Picture Files

- 1 Right click the desired plots and/or statistics window and select **Export Tubes to Files**. The Export Tubes to Files window appears.

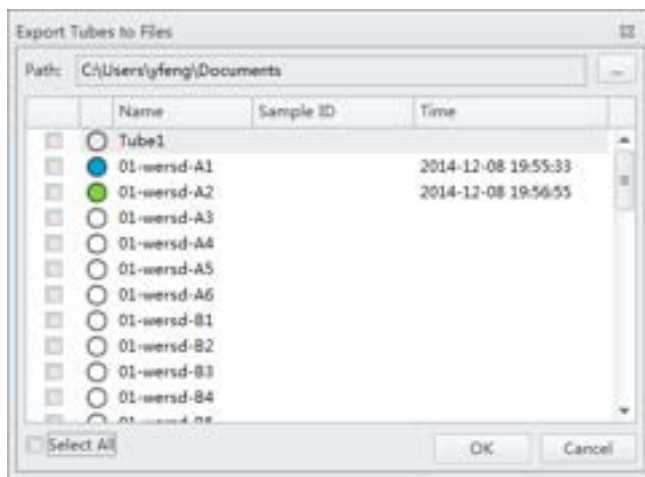
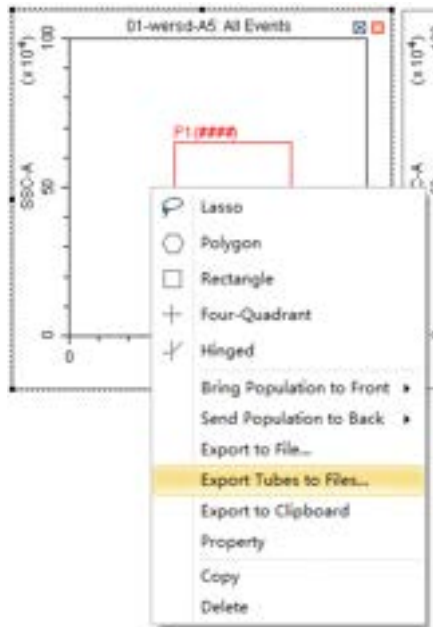

- 2 Select the tubes to export.

- 3 Select the path.

- 4 Select **OK**.

NOTE The plots of the selected tubes save as .bmp file.

Importing and Exporting Instrument Settings

The CytExpert software supports importing and exporting instrument settings to facilitate the experiment process. Only instrument settings identical to the current configuration can be imported with current detector settings.

Select  to edit gain, threshold, and width. These can be imported from an experiment file or from a catalog of instrument settings.

Importing Instrument Settings

- 1 Select the desired sample tube to import. Then select .

NOTE Instrument settings can only be imported into tubes where data has not yet been recorded.

- 2 Select **Import From File**, locate the file with the required instrument settings, or select **Import From Catalog** to import the instrument settings.

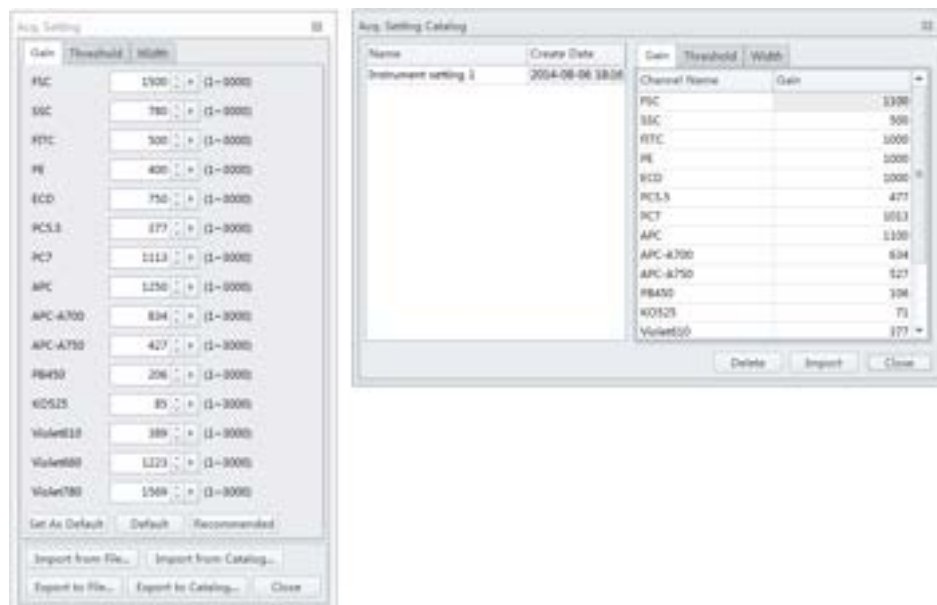

- 3 Select **Close**.

Exporting Instrument Settings

- 1 Select the desired sample tube to export. Then select .
 - 2 Select **Export To File** to export a current set of instrument settings, stored in a file ending in .acq.
Or
Select **Export To Catalog**, give a name to the settings to be exported, and export the file to the software's Acquisition Setting Catalog, then select **OK**.
 - 3 Select **Close**.
-

Importing and Exporting Compensation Settings

The software supports unrestricted importing and exporting of compensation data, regardless of whether the sample tube data has already been acquired. Imported compensation values only cover channels identical with the current instrument configuration. The software automatically adjusts compensation values according to differences in the gain level. Refer to [Importing and Exporting Compensation](#) in [CHAPTER 6, Compensation](#).

Printing Graphics

CytExpert offers printing functionality for the plots and tables that appear in the plot area. The software also lets you save these images by converting them into .jpg or .pdf files.

Select  in the printer control area to print directly. Or, select the print drop-down arrow for the following options:

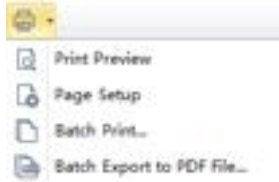

-  **Print Preview.** Used to access the Preview screen.

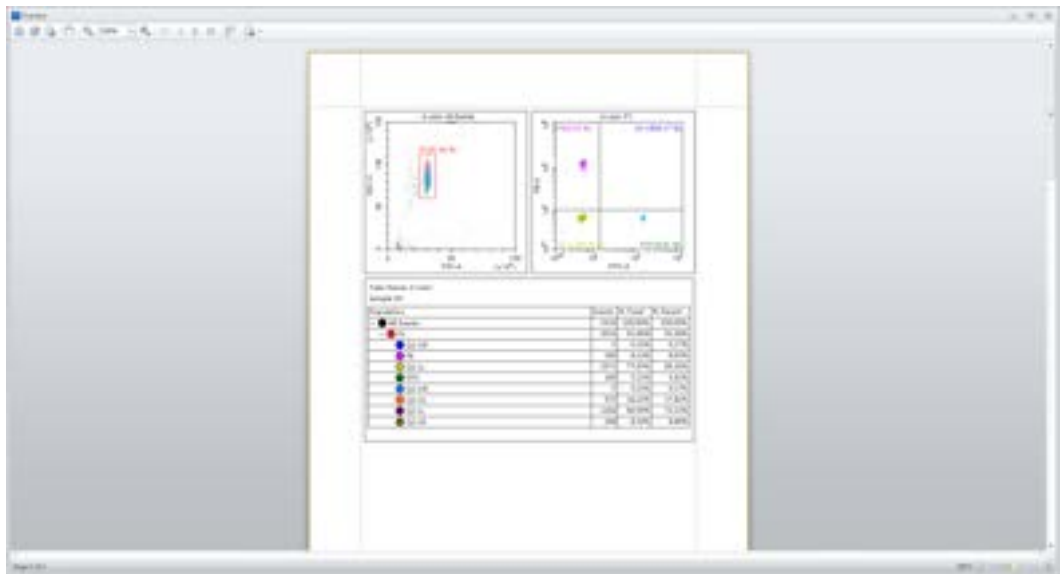



- Select  to select the required format of the file to be exported and to save the file in that format.

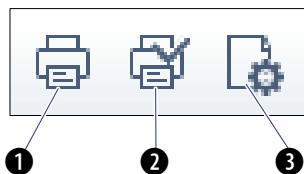

- Print preview also lets you choose between printing directly (1), modifying the printer configuration (2), or adjusting the page settings (3).



-  **Page Setup.** Used to adjust the page settings.

-  **Batch Print.** Used to print data for multiple tubes.
 1. Select **Batch Print.** The Batch Print window appears.

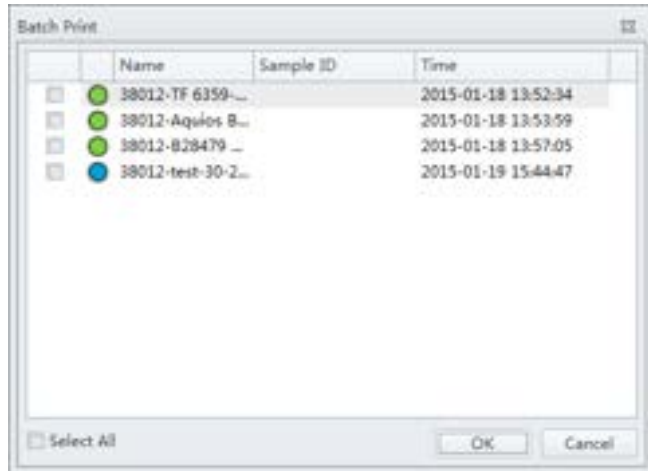

2. Select the tubes to print.
3. Select **OK.**

-  **Batch Export to PDF File.** Used to print a PDF of the data for multiple tubes.
 1. Select **Batch Export to PDF File.** The Batch Export to PDF File window appears.

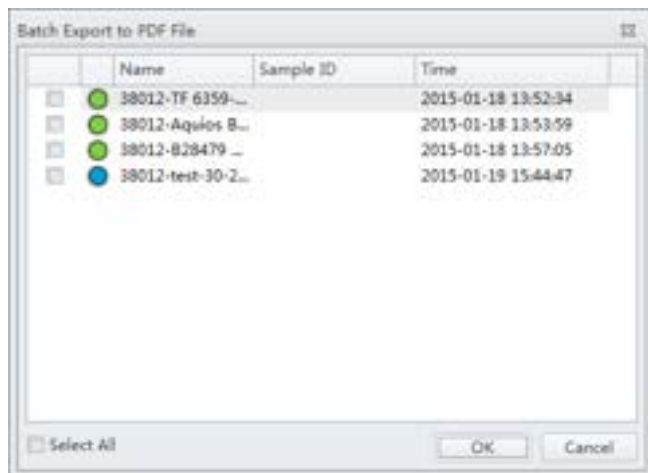

2. Select the tube to print to PDF.
3. Select **OK.**

Saving the Experiment

Selecting **Save** in the File menu allows you to save the experiment.

Selecting **Save As** and saving the experiment under a different name allows you to create a backup.

Selecting **Save As Template** in the File menu allows you to save the experiment as a template.

Concluding the Experiment

Conclude the experiment as follows:

- Select **Standby** to return the instrument to the standby state.
- Shut down the system. Refer to [CHAPTER 8, Daily Shutdown](#).

Overview

This chapter describes how to create a compensation experiment and automatically calculate compensation values after acquiring the data. It also explains how to use these calculations for other experiments.

Compensation involves correction for fluorescence spillover emitted by the primary fluorochrome that is detected by the secondary fluorescent channels. For example, the excitation and the resulting fluorescence emission for the PE fluorochrome leads to the spillover fluorescence detected in the ECD, PC5.5, and PC7 channel. Compensation reduces the spillover fluorescence of the PE-positive population to match the background of the PE-negative population in the secondary channels. Compensation requires a single positive and a negative population for every single color sample.

Properly configured compensation eliminates false data interpretation caused by spillover fluorescence from another fluorochrome. Refer to [Figure 6.1](#) and [Figure 6.2](#) for an example of plots before and after compensation. Compensation adjustments can be completed during the data acquisition process or after the data acquisition process is complete.

Figure 6.1 Before Compensation

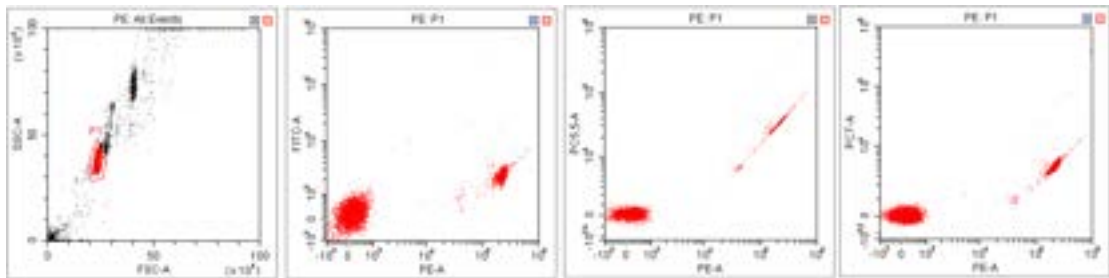
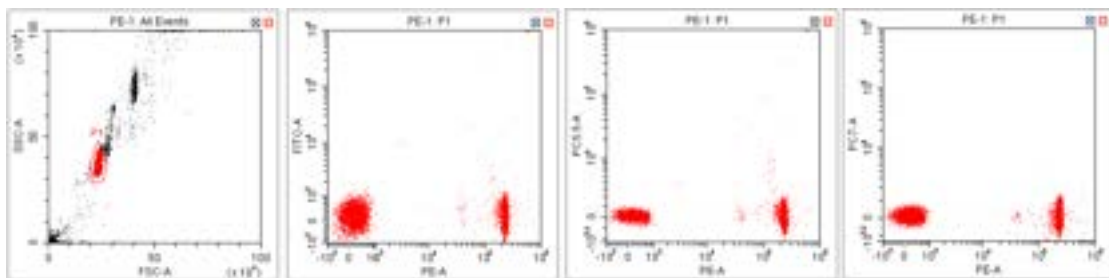
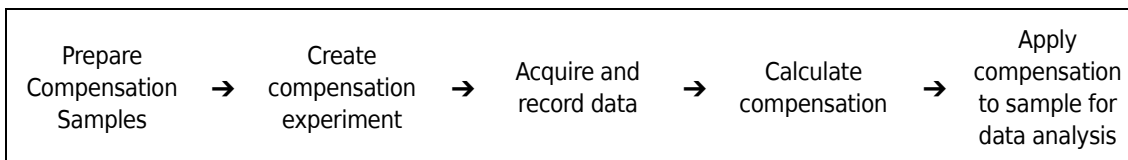

Figure 6.2 After Compensation



Workflow:



This chapter contains information on:

- [Creating a Compensation Experiment](#)
- [Creating a Compensation Experiment \[With Plate Loader\]](#)
- [Creating the Compensation Matrix from Previously Acquired Data](#)
- [Adjusting Compensation](#)

Creating a Compensation Experiment

Before creating a compensation experiment, you must verify the instrument's detector configuration settings (see [Verifying, Selecting, Editing, and Creating Detector Configuration](#) in [CHAPTER 5, Data Acquisition and Sample Analysis](#)).

- 1 Select **New Compensation** in the File menu or on the start page to create a new compensation experiment.

NOTE The file name of the newly created compensation experiment has a ".xipc" suffix.

- 2 Navigate to the desired file path and select **Save**. The Compensation Setup window appears.

CAUTION

Risk of erroneous results. Select an unstained tube, according to which the fluorescence background will be set. If there is not an unstained tube, then each single color tube must have a negative population.

It is important to specify the appropriate sample type. Otherwise, the background information could be incorrectly calculated and lead to erroneous compensation results.

- 3 Select the channel requiring compensation calculation, and the sample type.

If a negative population is not present in each single color tube, then an unstained control tube is recommended.

NOTE The default selection is **Area**. The unstained negative control tube can be selected if needed.

NOTE Label and lot number information can be retained in the Compensation Library to facilitate future compensation calculations.

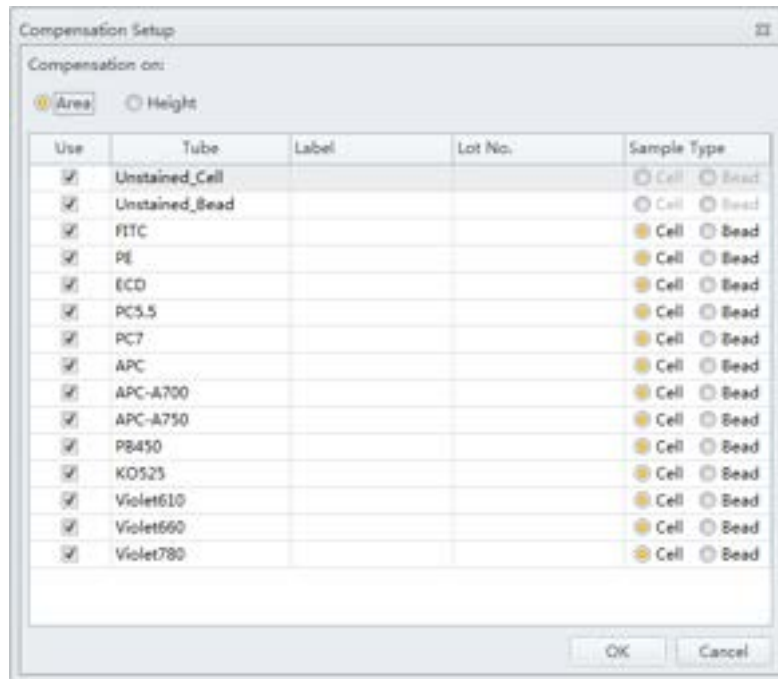

4 Select **OK**.

After confirmation, the software automatically generates the following compensation experiment.

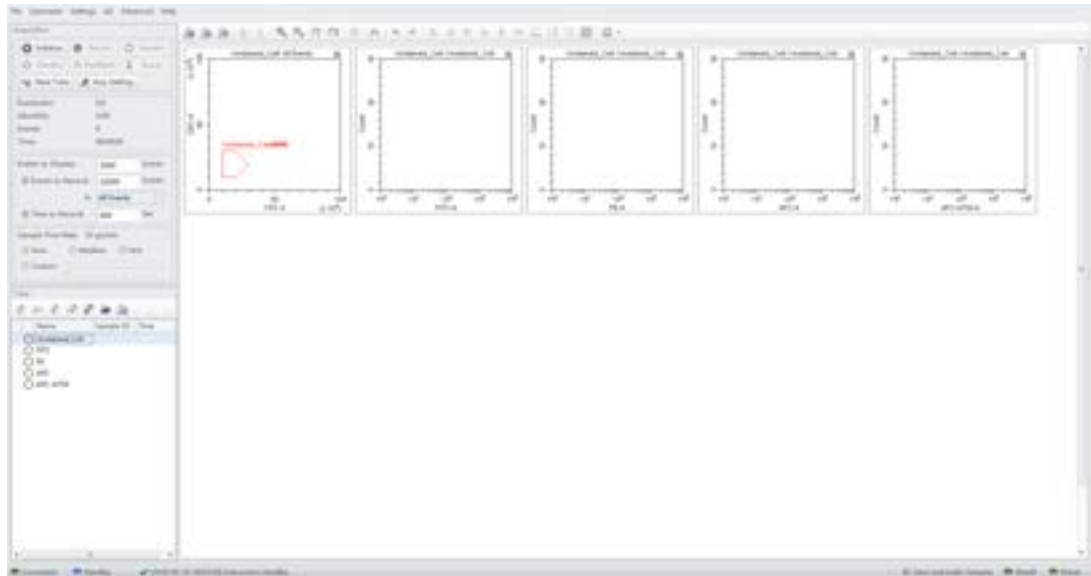

NOTE Select Area to calculate compensation based on the Area measured. Alternatively, select Height to calculate compensation based on the Height measured.

Preparing the Compensation Sample

To perform a compensation experiment, prepare:

- Single positive control tube for each color
- Negative control tube (optional)

NOTE A negative control tube is required if a single positive control tube does not contain a negative population.

For the negative control sample and single positive control sample, you can use blood, cells, or dedicated compensation beads such as VersaComp Antibody Capture Beads. For details, refer to the appropriate reagent instructions for use. The negative control tube is used to determine the autofluorescence of the sample.

Using Control Samples to Generate the Compensation Matrix

Defining the Negative Population Using Unstained Samples

- 1 Confirm that the instrument has been initialized. Refer to [Initializing the Instrument](#) in [CHAPTER 3, Daily Startup](#).

CAUTION

Risk of erroneous results. Calculations based on excessively small volumes of sampled data can be inaccurate. Ensure that more than 1,000 positive events and more than 1,000 negative events are sampled. If the ratio of positive cells is comparatively low, increase the number of acquisition events to a suitable amount.

- 2 Import the gain setting and apply the setting to all tubes. Refer to [Adjusting the Gain](#) in [CHAPTER 5, Data Acquisition and Sample Analysis](#). Use the pan tool to adjust the axis scale so that the sample signal appears in a suitable position. Adjust the gate so that it encloses the target cell population (see [Creating Plots and Gates](#) in [CHAPTER 5, Data Acquisition and Sample Analysis](#)).

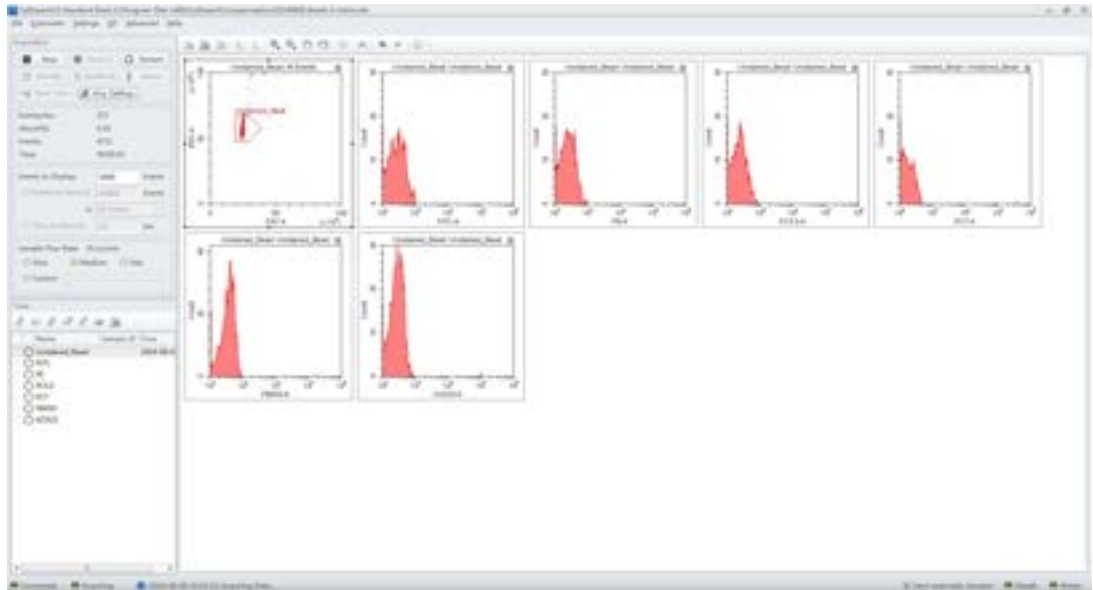

- 3 Place the negative control tube in the sample tube holder.
- 4 Select the unstained tube.
- 5 Select **Run** to load the sample.

-
- 6 Set an appropriate number of cells to save in Events to Record located on the left side of the screen.

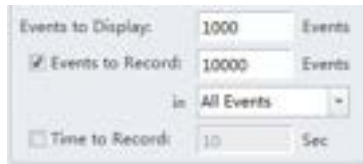

Events to Display: 1000 Events
 Events to Record: 10000 Events
in: All Events
 Time to Record: 10 Sec

-
- 7 Select **Record** to save the data.

Running the Single Positive Control Samples

- 1 Place the single positive tube in sample loading position (see [Figure 1.9](#)).
- 2 Select the appropriate, corresponding tube.
- 3 Select **Run** to load the sample.

CAUTION

Risk of erroneous results. Calculations based on excessively small volumes of sampled data can be inaccurate. Ensure that more than 1,000 positive events and more than 1,000 negative events are sampled. If the ratio of positive cells is comparatively low, increase the number of acquisition events to a suitable amount.

- 4 Move the gate in the FSC/SSC plot so that it encloses the desired population. Move the positive gate in the plot so that it encloses the positive population. If necessary, move the positive gate so that it encloses the positive population.

NOTE Figure 6.3 shows an example of selecting the positive population when the negative population is defined by the unstained sample.

Figure 6.3 Positive Population Selected from the Unstained Sample



1. Positive population

NOTE Figure 6.4 shows an example of selecting both the positive and negative populations without an unstained sample.

Figure 6.4 Positive and Negative Populations Without an Unstained Sample

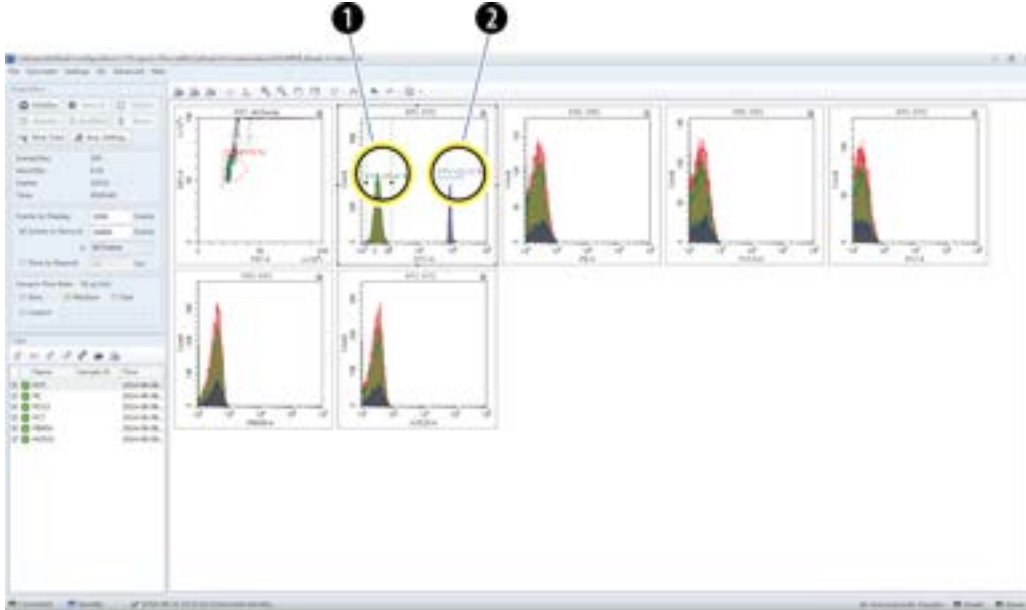

1. Negative population
2. Positive population

5 Select **Record**.

6 Repeat steps 1-5 to acquire data from subsequent single positive sample tubes.

⚠ CAUTION

Risk of erroneous results. While the software automatically adjusts the compensation calculation according to gain, excessive adjustment of the fluorescence gain could lead to inaccurate results.

7 If necessary, adjust gain while acquiring data from single positive sample tubes. Refer to [Adjusting the Gain](#) in [CHAPTER 5, Data Acquisition and Sample Analysis](#).

Calculating Compensation Values

1 Check all acquired sample tubes and confirm that the gating is appropriate.

- 2 Select  or select **Compensation Calculation** in the Compensation menu to calculate the compensation values.



The Compensation Matrix window appears, displaying the calculated compensation values.

Channel	-FITC%	-PE%	-PCD%	-PC3%	-PC7%	-APC%	-APC-A750L	-APC-A750L	-PE45%	-KOS2%	-Violet1%	-Violet60%	-Violet70%
-FITC	0.00	0.11	0.02	1.43	0.00	0.08	0.00	0.00	0.00	0.00	0.11	0.00	0.02
-PE	35.08	0.00	18.23	1.13	2.39	0.00	0.10	0.00	0.00	1.14	4.30	0.57	0.01
-PCD	11.81	41.79	0.00	0.35	1.71	0.00	0.09	0.00	0.00	0.80	9.47	0.34	0.02
-PC3	4.96	18.15	65.09	0.00	1.84	0.12	0.88	0.00	0.00	0.49	9.15	2.94	0.07
-PC7	1.36	4.32	19.07	71.85	0.00	0.17	1.04	1.39	0.00	0.05	3.28	0.58	7.29
-APC	0.02	0.03	1.12	2.67	0.22	0.00	9.25	6.67	0.00	0.18	1.30	75.01	0.06
-APC-A750	0.01	0.15	0.45	43.95	0.50	28.94	0.00	2.48	0.00	0.20	0.50	36.76	0.36
-APC-A750L	0.10	0.21	0.20	21.49	15.85	13.34	36.58	0.00	0.00	0.11	0.23	14.52	23.06
-PE45	0.10	0.22	0.00	0.04	0.00	0.00	0.15	0.00	0.00	8.26	8.62	6.12	2.84
-KOS2	1.89	0.13	0.00	0.03	0.11	0.00	0.06	0.00	1.67	0.00	0.95	0.93	0.19
-Violet1	0.47	1.11	6.79	0.02	1.14	0.01	0.05	0.00	0.58	81.38	0.00	13.87	0.08
-Violet60	0.26	1.48	1.56	0.11	0.00	1.03	0.19	0.10	0.00	45.00	82.38	0.00	0.11
-Violet70	0.11	0.21	0.78	4.62	8.40	0.88	2.22	1.72	0.00	12.20	30.20	27.58	0.00

NOTE The primary fluorescence channels are listed in columns; the secondary fluorescence channels are listed in rows.

- 3 Select **Save As** to export the compensation matrix as a .comp file and specify where to save it.

NOTE The compensation matrix can also be imported for use in other experiments.

- 4 Select **Save To Compensation Library** to save the single color compensation values in the compensation library.

- 5 Specify the key words and select **OK**.



NOTE The settings stored in the compensation library are specific to the detector configuration. The compensation library can only be applied when the detector configurations are the same.

At any time, saved compensation experiments can be reopened and the compensation values recalculated.

- 6 Select **Close**.

Creating a Compensation Experiment [With Plate Loader]

Before creating a compensation experiment, you must verify the instrument's detector configuration settings (see [Verifying, Selecting, Editing, and Creating Detector Configuration](#) in [CHAPTER 5, Data Acquisition and Sample Analysis](#)).

- 1 Select **New Compensation** in the File menu or on the start page to create a new compensation experiment.

NOTE The file name of the newly created compensation experiment has a ".xipc" suffix.

- 2 Navigate to the desired file path and select **Save**. The Compensation Setup window appears.

- 3 Select the plate type and sampling sequence located in the top, right of the Compensation Setup window.

CAUTION

Risk of erroneous results. Select an unstained tube, according to which the fluorescence background will be set. If there is not an unstained tube, then each single marker tube must have a negative population.

It is important to specify the appropriate sample type. Otherwise, the background information could be incorrectly calculated and lead to erroneous compensation results.

- 4 Select the channel requiring compensation calculation, and the sample type.
If a negative population is not present in each single color well, then an unstained control well is recommended.

NOTE The default selection is **Area**. The unstained negative control well can be selected if needed.

NOTE Label and lot number information can be retained in the Compensation Library to facilitate future compensation calculations.

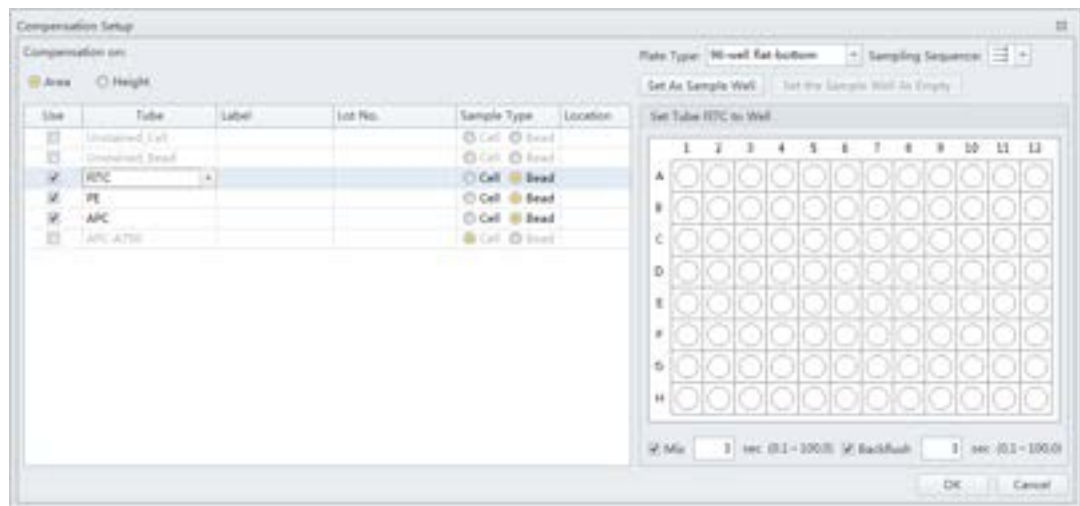

- 5 Select the Mix and Backflush settings in the bottom, right of the Compensation Setup window.

- 6 Assign the well locations.
 - a. Select the fluorochrome.
 - b. Select the desired sample well location for the fluorochrome.
 - c. Select **Set As Sample Well**.

NOTE The well location populates in the location column.

d. Repeat Steps a-c for each fluorochrome.

7 Select **OK**.

After confirmation, the software automatically generates the following compensation experiment.

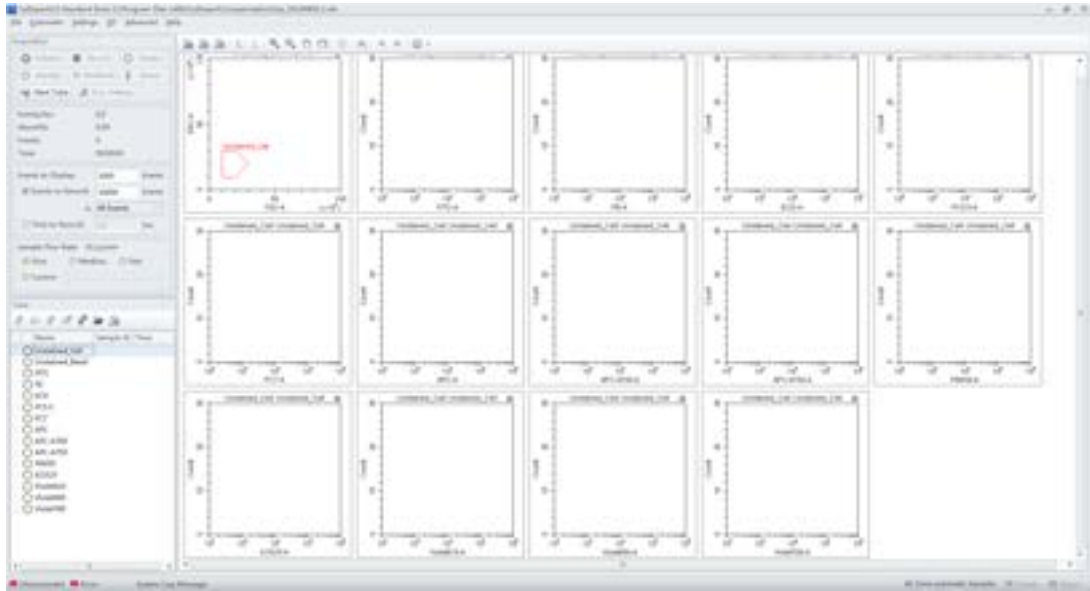

NOTE Select Area to calculate compensation based on the Area measured. Alternatively, select Height to calculate compensation based on the Height measured.

NOTE If the plate settings require modification, select . The Compensation Setup window appears.

8 Before acquiring data, ensure the plate has been loaded properly. Data can be acquired as a single well or as a set of wells. Refer to [Running Samples](#) in [CHAPTER 5, Data Acquisition and Sample Analysis](#).

Preparing the Compensation Sample

To perform a compensation experiment, prepare:

- Single positive control well for each color
- Negative control well (optional)

NOTE A negative control well is required if a single positive control well does not contain a negative population.

For the negative control sample and single positive control sample, you can use blood, cells, or dedicated compensation beads such as VersaComp Antibody Capture Beads. For details, refer to the

appropriate reagent instructions for use. The negative control tube is used to determine the autofluorescence of the sample.

Using Control Samples to Generate the Compensation Matrix

Refer to [Defining the Negative Population Using Unstained Samples](#) and [Running the Single Positive Control Samples](#) in CHAPTER 6, Compensation.

Calculating Compensation Values

1 Check all acquired sample tubes and confirm that the gating is appropriate.

2 Select  or select **Compensation Calculation** in the Compensation menu to calculate the compensation values.



The Compensation Matrix window appears, displaying the calculated compensation values.

Channel	FITC%	PE%	SCD%	PC3%	PC7%	APC%	APC-A750%	APC-A750%	PE450%	KOS2%	Violet1%	Violet60%	Violet70%
PC		0.06	0.11	0.02	1.41	0.00	0.08	0.00	0.00	0.00	0.01	0.11	0.00
PE	35.08		18.23	1.13	2.39	0.00	0.10	0.00	0.00	1.14	4.20	0.07	0.01
SCD	11.81	41.74		0.55	1.75	0.00	0.06	0.00	0.00	0.80	9.47	0.34	0.02
PC3	4.96	18.13	65.08		1.84	0.52	0.88	0.01	0.00	0.49	9.35	2.04	0.07
PC7	1.36	4.32	19.07	71.85		0.17	1.04	1.39	0.00	0.05	3.28	0.98	7.20
APC	0.02	0.03	1.12	2.67	0.22		4.25	6.07	0.00	0.16	1.30	75.01	0.06
APC-A750	0.01	0.15	0.40	43.95	0.00	28.94		2.48	0.00	0.20	0.50	36.74	0.36
APC-A750	0.10	0.21	0.20	21.48	53.85	13.34	36.58		0.00	0.11	0.25	14.52	23.06
PE450	0.10	0.22	0.00	0.04	0.00	0.00	0.15	0.00		8.26	8.62	6.12	2.84
KOS2	1.89	0.15	0.00	0.03	0.11	0.00	0.06	0.00	1.67		0.25	0.35	0.19
Violet1	0.47	1.11	4.79	0.52	1.14	0.01	0.05	0.00	0.58	81.36		13.87	0.08
Violet60	0.26	1.48	1.56	0.21	0.90	1.03	0.18	0.10	0.00	45.00	82.28		0.11
Violet70	0.11	0.21	0.78	4.62	8.40	0.88	2.22	1.72	0.00	12.20	30.20	27.58	

3 Select **Save As** to export the compensation matrix as a .comp file and specify where to save it.

NOTE The compensation matrix can also be imported for use in other experiments.

4 Select **Save To Compensation Library** to save the single color compensation values in the compensation library.

-
- 5 Specify the key words and select **OK**.



NOTE The settings stored in the compensation library are specific to the detector configuration. The compensation library can only be applied when the detector configurations are the same.

At any time, saved compensation experiments can be reopened and the compensation values recalculated.

-
- 6 Select **Close**.

Creating the Compensation Matrix from Previously Acquired Data

The software supports importing single color data acquired from other experiments into a compensation experiment to perform compensation calculations. The data to be imported must match the active detector configuration at the time that the compensation experiment was created. Otherwise, the data cannot be imported. It is important to ensure that imported data comes from the same instrument and uses the same configuration and channels. Data originating from a different instrument will cause erroneous calculations.

-
- 1 Select **New Compensation** from the File menu or the start page.
 - 2 To create a compensation experiment, select the required channels. Refer to [Setting the Channel and Label](#) in [CHAPTER 5, Data Acquisition and Sample Analysis](#).

- 3 Right-click on the appropriate test tube and select **Import FCS File**. Locate the corresponding data file and import the file. Only files compatible with the detector configuration are supported by the software for importing.

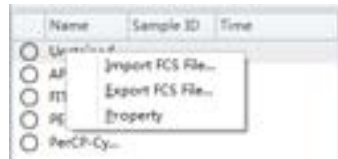

F in front of a test tube indicates that the corresponding data have been imported.

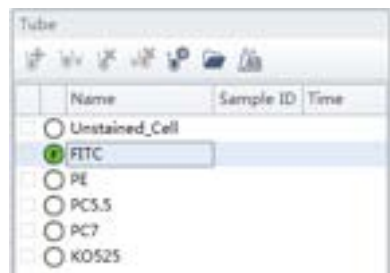

- 4 After importing the data, adjust the gates to properly identify the positive population and the negative population for each single-color samples.
- 5 Calculate the compensation values and export them. Refer to [Calculating Compensation Values](#).

Adjusting Compensation

Manually Adjusting Compensation

The compensation can be manually adjusted in an experiment in two ways:

- Select the bivariate plot which the compensation needs to be adjusted. Select  from the graphic control area, then click and drag the mouse pointer up and down or left and right inside the plot to adjust compensation.
- Select **Compensation Matrix** in the Setting menu to open the compensation matrix. Adjust the compensation value between the primary channel and the secondary channel.

Importing and Exporting Compensation

Importing Compensation Settings from Compensation Matrix Files

- 1 Select the desired sample tube for importing compensation values.
- 2 Select **Compensation Matrix** in the Setting menu.
- 3 Select **Import** and locate the path where compensation matrix files are saved. Select the corresponding compensation matrix file (.comp) to import the compensation values.
You can also select **Import from Library** to import compensation values from the compensation library. The Import from Compensation Library window appears. Refer to [Importing Compensation Settings from the Compensation Library](#).
Both methods allow you to import the compensation values with or without the adjustment based on the gain settings.
- 4 After opening the desired compensation file, the Import Compensation window appears. Select one of the following:
 - Import compensation matrix and transform it with current gains.
 - Import compensation matrix.
 - Import compensation matrix and gain.

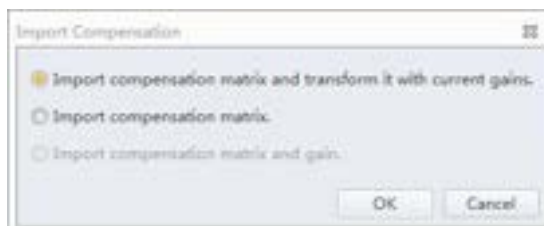

NOTE

- If the tube does not have any data when importing compensation values calculated from other instrument settings, the software prompts you to select whether the gain settings must be imported as well. Select **Yes** to import fluorescence channel gains settings along with the rest of the data. Select **No** to allow the CytExpert software to adjust the compensation matrix values based on the current gain settings.
- If the tube does have data when importing compensation values from other instrument settings, the software prompts you to select whether the compensation values are adjusted based on the current gain settings.
- It is important to note that automatic adjustments to compensation values calculated from other instrument gain settings could result in incorrect compensation. Always review the data after importing compensation values to ensure the sample is compensated properly.

5 Select **OK**.

6 If necessary, select **Apply to** to apply the compensation values to the selected test tubes.

7 Select **Close**.

Importing Compensation Settings from the Compensation Library

You can choose which single color data to include from the compensation library. Only single color data in the compensation library from the same detector configuration can be imported into the compensation matrix.

NOTE Files available in the compensation library are configuration-specific. The compensation library only displays the files created under the current default configuration.

1 Select **Import From Compensation Library** to select which compensation values to import from the compensation library.

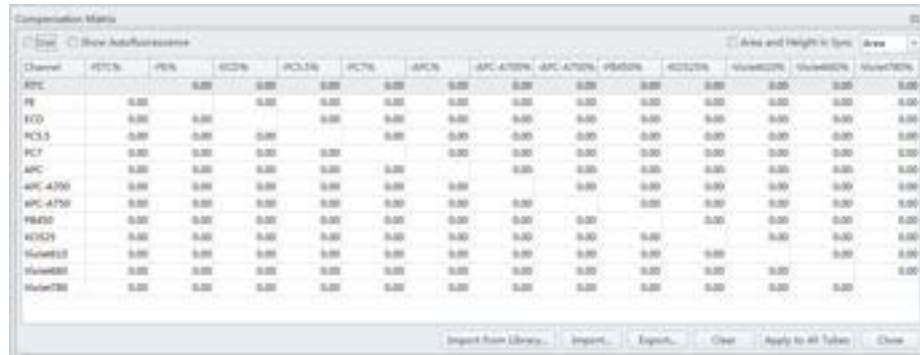

- 2 In the Keywords column, the corresponding compensation values can be selected for each channel. The compensation values of the same keyword can also be selected using the drop-down menus in the Keywords column.

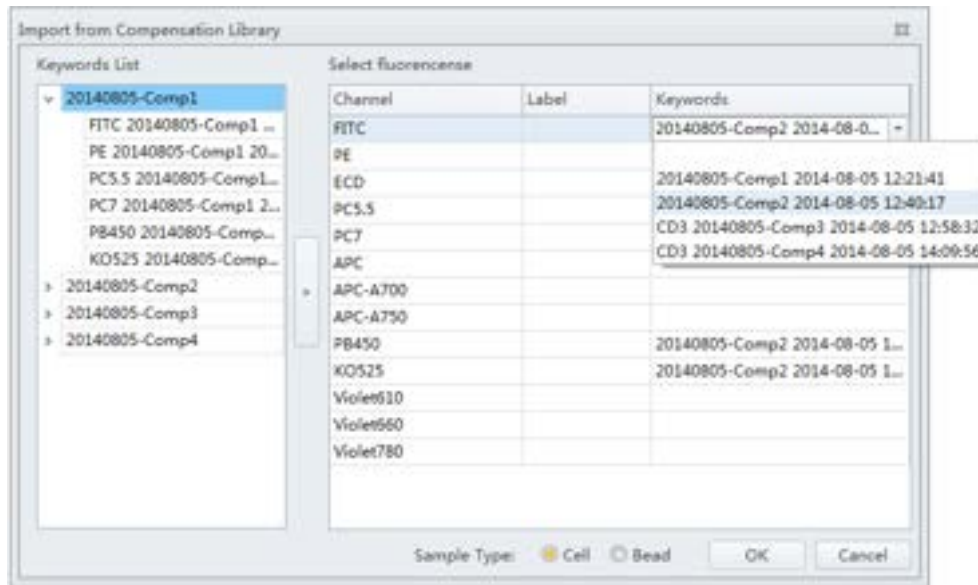

- 3 Select **OK** to import the compensation values.

Exporting Compensation Settings

- 1 Select the desired sample tube to export.
- 2 Select **Compensation Matrix** in the Setting menu.

3 Select **Export** to specify a path and filename for the compensation file you are saving.

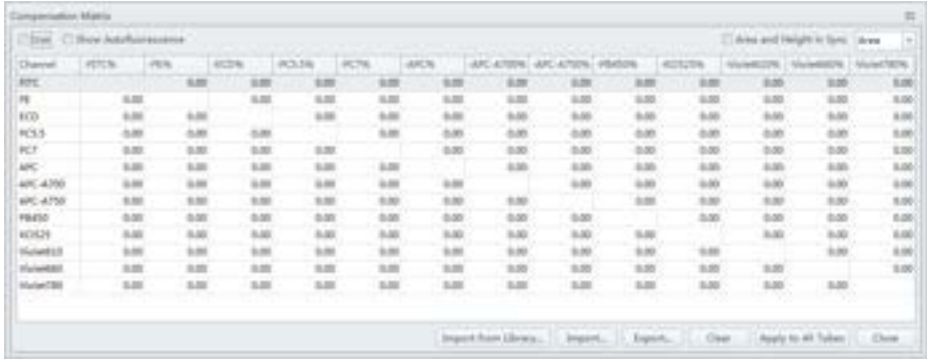

4 Select **Save**.

NOTE The generated file ends in .comp.

Managing the Compensation Library

Compensation values can be managed in the Compensation Library.

- 1 Select **Compensation Library** from the Settings menu. The Compensation Library window appears.

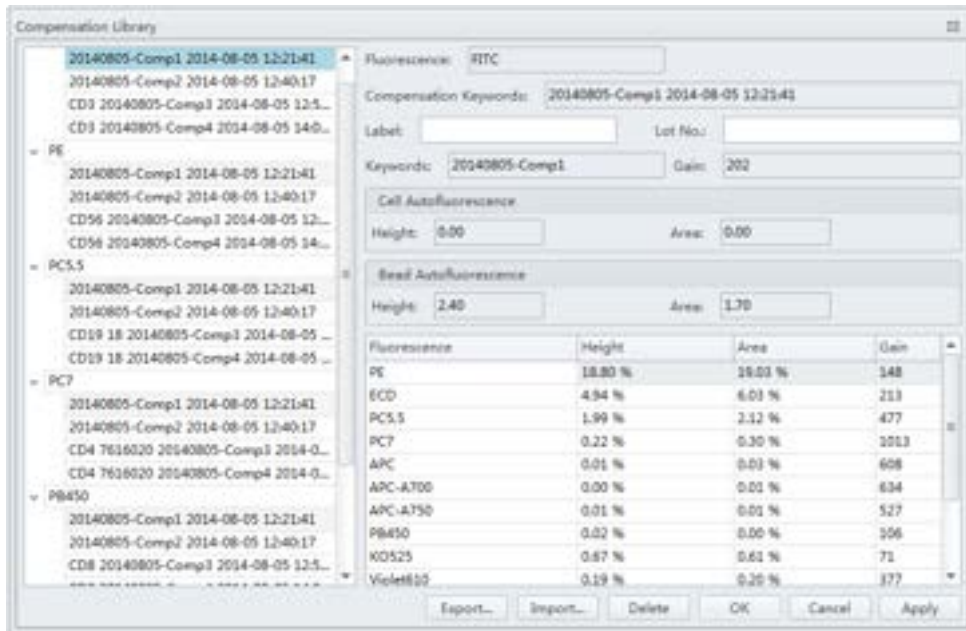
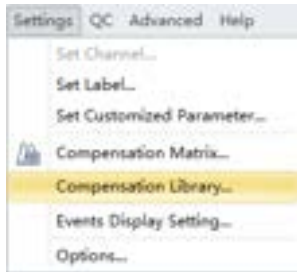

NOTE The Compensation Library is arranged by fluorescence detection channels.

- 2 Select the desired single color sample. The compensation information appears on the right side of the window.

NOTE Existing compensation values (height and area) can be modified by double-clicking the appropriate column in the Compensation Library window.

- 3 Enter the Label and Lot No. for the specified single color sample.

-
- 4 Select **OK**.
-

Adding Channels for Compensation

Channels requiring compensation calculations that have not been previously acquired can be added to the compensation experiment by acquiring the necessary positive tubes.

- 1 In the compensation experiment, select  in the compensation controls, or select **Compensation Setup** in the Compensation menu. The Compensation Setup window appears.

- 2 Select the channel that needs to be added and select **OK**.

The software automatically adds a new single positive tube to the compensation experiment. It also adds a plot with appropriate parameters in the negative control tube.

NOTE It is important to ensure that the data for the previously acquired negative control now includes the data of the newly added channel and that the settings are correct. Otherwise, you must reacquire the negative control tube and adjust the gain.



- 3 Repeat 1-2 to detect and acquire newly added single positive sample data.
 - 4 Repeat [Calculating Compensation Values](#) to recalculate and export the compensation results.
-

Overview

This chapter discusses how to use the Analysis screen to analyze data. Data can be analyzed using any computer equipped with the CytExpert software. No online connection is required.

Workflow:

Import experiment or data → Plot and configure statistics → Export results

This chapter contains information on:

- [Copying Experiments and Importing Data](#)
- [Setting the Plots and Statistics](#)
- [Calculating Sample Injection Volume and Concentration](#)
- [Adjusting Compensation Settings](#)
- [Exporting Results](#)

Copying Experiments and Importing Data

Copying a Previously Acquired Experiment

Experiments acquired by other CytoFLEX instruments using CytExpert software can be imported to your computer for analysis, provided your computer also uses CytExpert software.

Select **Open Experiment** from the Start page or select **Open Experiment** in the File menu to open the copied experiment. Then, select **Save As**.

NOTE The .xit and data folder must be stored in the same path.

Importing Previously Acquired Data

The CytExpert software can import and analyze compatible FCS data files acquired by other CytoFLEX flow cytometers.

- 1 Create a new experiment or open a saved experiment. Refer to [Creating an Experiment](#) in [CHAPTER 5, Data Acquisition and Sample Analysis](#).

- 2 In the new or opened experiment, select **Import FCS File** in the File menu to import the data files.

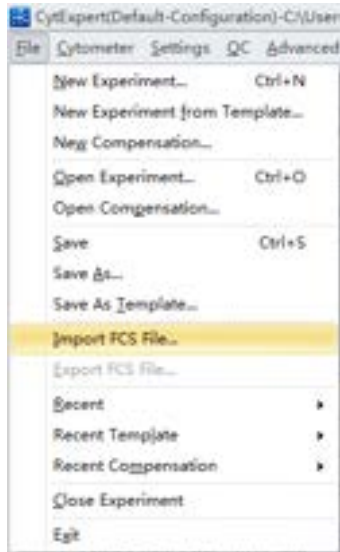

Imported data files appear in the Tube screen.



The  symbol in front of each data tube indicates that the data tube is an imported data file. Imported data files are copied and saved in the folder where the current experiment data files are saved.

Setting the Plots and Statistics

Opening the Analysis Screen

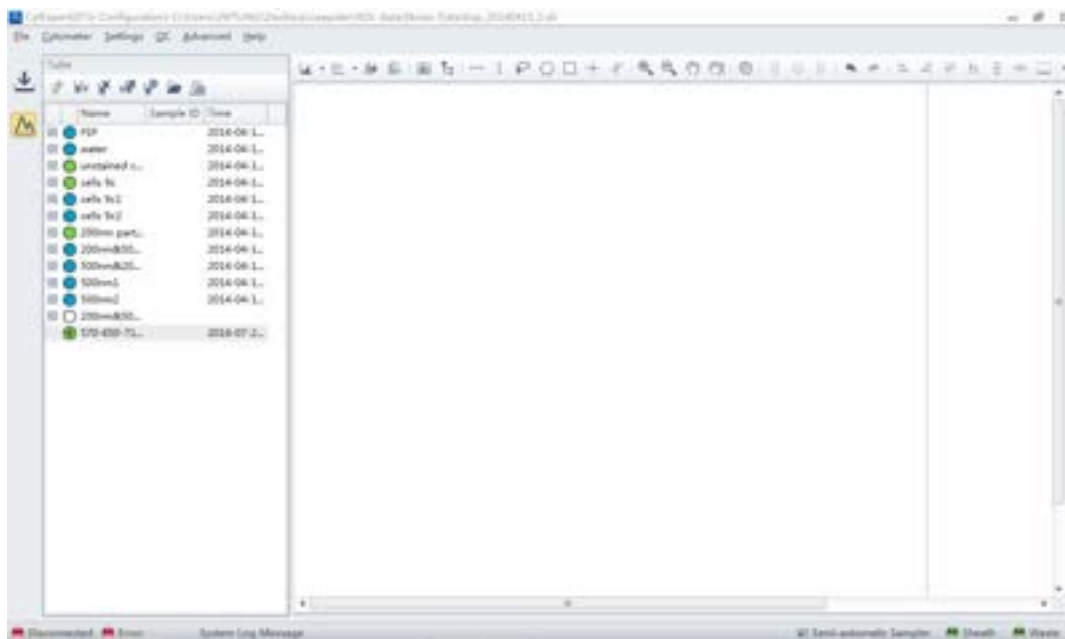
- 1 Select  on the left to enter the Analysis screen.



- 2 Copy plots obtained during data acquisition.
 - a. If you need original plots used during data acquisition, select  to access the Acquisition screen.
 - b. Select the appropriate plots.
 - c. Right-click the selected plots and select **Copy** from the drop-down menu or press Ctrl+C to copy.
 - d. Select  to return to the Analysis screen.
 - e. Select the required test tube from the tube list on the left side of the screen.
 - f. Right-click the plot area and select **Paste** from the drop-down menu or press Ctrl+V to paste the plot.



NOTE Pasted plots include all gates, but the gate names are reassigned.

-
- 3** New plots can be created according to need. After selecting the test tubes requiring analysis, use the plotting control buttons at the top of the screen to create a new plot.

NOTE Each graph in the **Analysis** screen may correspond to different data. Pay special attention to each plot's heading to avoid mistakes during analysis.

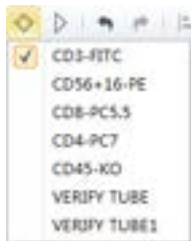
-
- 4** Use the sample selection controls in the graphics controls toolbar at the top of the page (see [Figure 2.1](#)) to change the data displayed in a plot.



- a.** Select the plot requiring a change to the data displayed. By pressing and holding the Ctrl key while selecting plots, you can select several plots at one time.
- b.** Select one of the two triangular sample selection buttons ( or ) to choose between the previous sample and the next sample, or select  to specify which data to display.

Creating Multi-Data Histograms and Dot Plot Overlays

The CytExpert software supports histogram and dot plot data overlay functionality, allowing you to combine data from differing sources onto the same histogram or dot plot.

- 1 Select **Histogram Overlay** under the histogram icon drop-down list to create a new multi-data histogram.



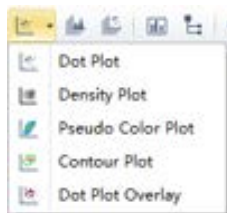

Or

- 1 Select **Dot Plot Overlay** under the dot plot icon drop-down list to create a new dot plot overlay.

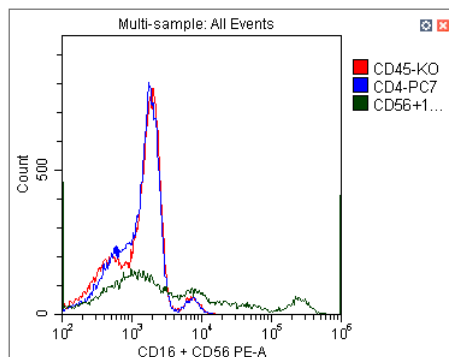
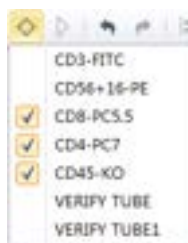

- 2 Select  to select samples for overlay display. Or, drag and drop samples from the tube list on the left into the histogram or dot plot overlay. The software automatically assigns different colors to different data.



To remove a sample, select  and uncheck the sample. Or, right-click the color legend and select **Remove [sample name]** or **Remove All Sample**. The corresponding data will no longer appear on the graph.

- 3 To change the color selections, right-click on the sample name in the legend located on the right side of the plot and select **Color** from the drop-down menu. A color pallet appears.

For configuring gates and generating statistics, refer to [CHAPTER 5, Data Acquisition and Sample Analysis](#).

Calculating Sample Injection Volume and Concentration

The CytoFLEX flow cytometer supports the calculation of the sample concentration based on the volume consumed and/or based on the known concentration of reference beads.

NOTE If necessary, calibrate the sample uptake rate (see [Calibrating the Sample Flow Rate](#) in [CHAPTER 11, Replacement/Adjustment Procedures](#)) prior to collecting data for volumetric analysis:

- Select the *cells/μL(V)* check box to calculate concentration directly.

NOTE The direct calculation of concentration can be affected by several conditions such as, the sample's viscosity and sample mixing. Uncalibrated sample volume uptake rates may lead to erroneous results.

- If using reference beads to calculate the concentration, select the *cells/μL(B)* check box and select the gated **Beads Population**. Enter the total number of reference beads as the **Beads Count**, as well as the sample volume in total. The software automatically calculates the original sample concentration based on the input values. (You can also enter the reference bead concentration directly in the beads count field and set the sample volume as 1.)

To obtain accurate calculations, throughout the data acquisition process, ensure that:

- The sample concentration is 2×10^4 - 10^7 units/mL.
- Samples are thoroughly mixed before loading and that they exhibit no apparent subsidence throughout the testing process.
- The detection rate is maintained at less than 10,000 events/second throughout the sampling process. When the detection rate does not exceed the stated event rate. Running medium to high acquisition speeds are considered more accurate.
- A constant sampling rate is maintained when recording data.
- You acquire at least 10 μL of sampling volume.

In the Statistics Setting screen, select **Volume** and the concentration item to see the corresponding information in the statistical table.

NOTE While collecting samples, instantaneous data calculation can appear inaccurate. Regard the calculation as accurate only after data acquisition has been completed.



Adjusting Compensation Settings

Data compensation can be carried out at any time. You can select the desired tube in the tube list on the left side of the screen and select  in the compensation controls, or select **Compensation Setup** in the Compensation menu. Refer to [Adjusting Compensation](#) in [CHAPTER 6, Compensation](#), for detailed instructions on adjusting compensation settings.

Exporting Results

Refer to [CHAPTER 5, Data Acquisition and Sample Analysis](#).

Overview

This chapter provides procedures for shutting down the CytoFLEX instrument.

Workflow:

Prepare the cleaning solution → Clean the instrument → Turn the instrument off

This chapter contains information on:

- [Preparing the Cleaning Solution](#)
- [Shutting Down the Instrument](#)

Preparing the Cleaning Solution

Required materials

Materials to prepare:

- 12 x 75 mm sample loading tube
- FlowClean
- Deionized water
- Bleach

Set aside 2 mL of FlowClean in one sample tube and 3 mL of the deionized water in a separate sample tube.

Shutting Down the Instrument

- 1 Run Daily Clean to clean the sample line. Refer to [Daily Clean](#) or [Daily Clean \[With Plate Loader\]](#) in [CHAPTER 10, Cleaning Procedures](#).
- 2 If necessary, empty all waste liquid from the waste container. Refer to [Emptying the Waste Container](#) in [CHAPTER 11, Replacement/Adjustment Procedures](#).
- 3 Remove the sample tube from the instrument and store according to your laboratory procedures.

-
- 4** Exit the software. The instrument automatically enters the standby state.

 - 5** Turn the computer off.

 - 6** Turn the Cytometer's main power switch off.

 - 7** If there are any spills, clean the sample station. Refer to [Cleaning the Sample Station](#) in [CHAPTER 10, Cleaning Procedures](#).
-

Overview

IMPORTANT In addition to the information stated, never disassemble the instrument or have it repaired by unauthorized personnel. Beckman Coulter bears no responsibility for any problems arising from the unauthorized repair of the instrument.

This chapter introduces solutions to common problems. If there is a problem, follow the information in this chapter to carry out self inspection. If the problem can not be resolved, contact your Beckman Coulter Representative.

This chapter contains information on:

- [Precautions/Hazards](#)
- [Hazard Labels and Locations](#)
- [RoHS Notice](#)
- [Disposal Precaution](#)
- [Troubleshooting Table](#)

Precautions/Hazards

Laser Related Hazards

Beckman Coulter design and manufacture of the instrument complies with the requirements governing the use and application of a laser specified in regulatory documents issued by the:

- U.S. Department of Health and Human Services
- Center for Devices and Radiological Health (CDRH)
- International Electrotechnical Commission (IEC)

In compliance with these regulatory documents, every measure has been taken to ensure the health and safety of users and laboratory personnel from the possible dangers of laser use.

Use the instrument according to the information in the manuals.

Use controls or adjustments or performance of procedures other than those specified herein might result in hazardous radiation exposure.

To ensure your safety, the Cytometer lasers are covered with protective shields. Do not remove these shields.

No user-servicable assemblies are accessible. Do not attempt to remove the laser or open it. The instrument has components that are dangerous to the operator. If any attempt has been made to defeat a safety feature, or if the instrument fails to perform as described in its manuals, disconnect the power and contact your Beckman Coulter Representative.

Laser Beam Hazards

The flow cytometer can contain up to 3 solid-state diode lasers that are capable of producing laser light at the following levels:

- 405-nm, 80-mW solid-state diode laser
- 488-nm, 50-mW solid-state diode laser
- 638-nm, 50-mW solid-state diode laser

A laser beam is a unique light source that shows characteristics different from conventional light sources. The safe use of the laser depends upon familiarity with the instrument and the properties of coherent, intense beams of light.



Risk of personal injury. The laser beam can cause eye damage if viewed either directly or indirectly from reflective surfaces (such as a mirror or shiny metallic surfaces). To prevent eye damage, avoid direct exposure to the laser beam. Do not view it directly or with optical instruments.

Indirect contact with the laser beam from reflective surfaces (such as jewelry or a screwdriver) is called specular reflection and might also cause damage.

For these reasons, it is important to:

- Limit access to the Cytometer to trained and experienced personnel.
- Never attempt to remove a shield housing a laser.
- Never remove a warning label.
- Contact your Beckman Coulter Representative if a label is missing or unclear.

Laser Warning Labels



Risk of personal injury from radiation exposure. Never remove the shield surrounding a laser. Never remove covers.

CDRH-approved and IEC compliant labels are also placed near or on those covers that when removed might expose laser radiation. If necessary, a cover with a CDRH-approved or IEC compliant label must be removed by a qualified Beckman Coulter Representative only.

Refer to the following figures for the locations of the CDRH-approved and IEC compliant labels:

See [Figure 9.1](#) for the Laser Warning Label on the Cytometer optical bench.

See [Figure 9.2](#) for the Laser Warning Label on the optical bench (located Inside the Cytometer).

See [Figure 9.3](#) for the Laser Warning Labels on the Cytometer Back Cover.

The laser product is classified as CLASS 1 when all protective measures are in place. This product complies with 21 CFR Parts 1040.10 and 1040.11 as well as EN60825-1. See [Figure 9.1](#).

Figure 9.1 Laser Warning Label on the Laser Optical Bench

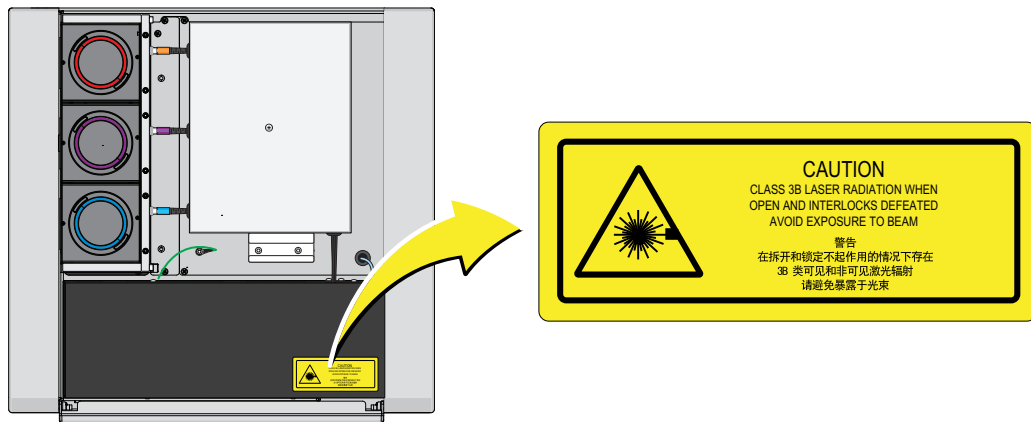

Figure 9.2 Laser Warning Label within the Optical Bench (Located Inside the Cytometer)

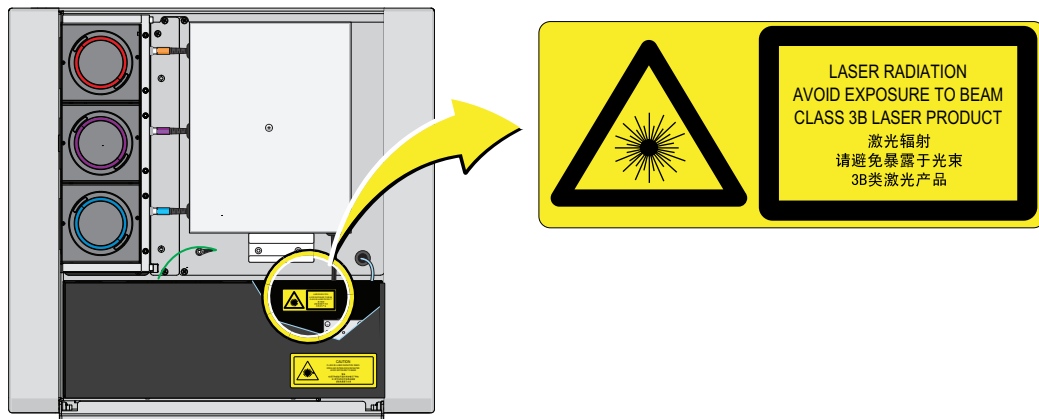
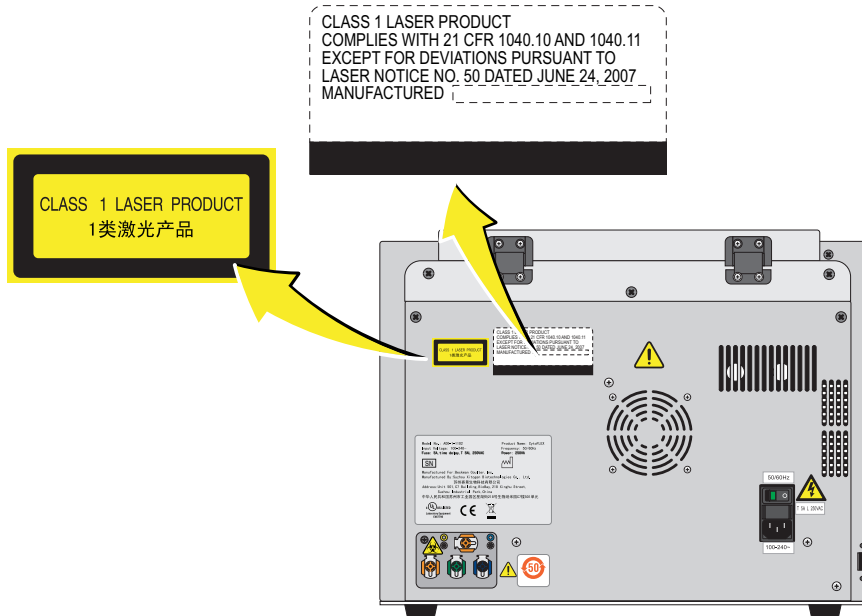

Figure 9.3 Laser Warning Labels on the Cytometer Back Cover



Hazard Labels and Locations

Carefully read the hazard warning labels on the instrument. The hazard labels are located on the instrument as indicated.

NOTE If a label is missing or unclear, contact your Beckman Coulter Representative.

Biohazard Label and Location

Figure 9.4 Biohazard Label on the Fluid Containers

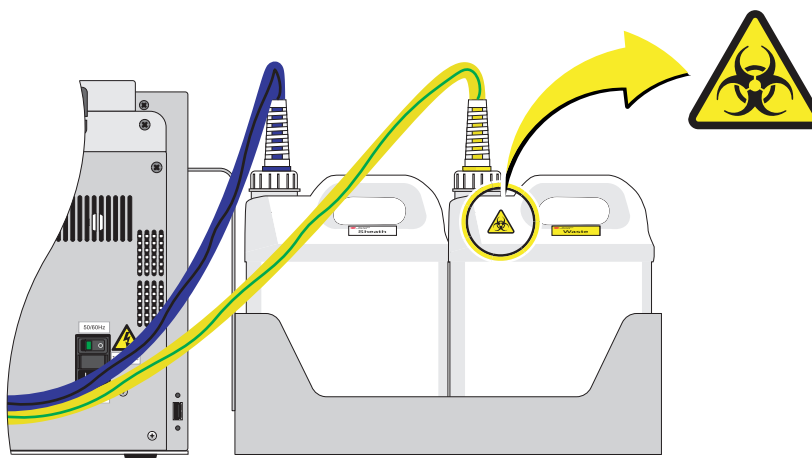
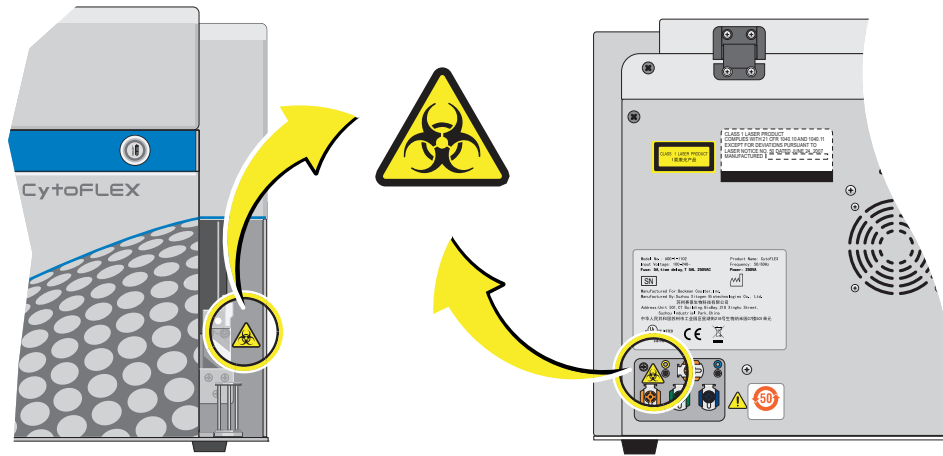
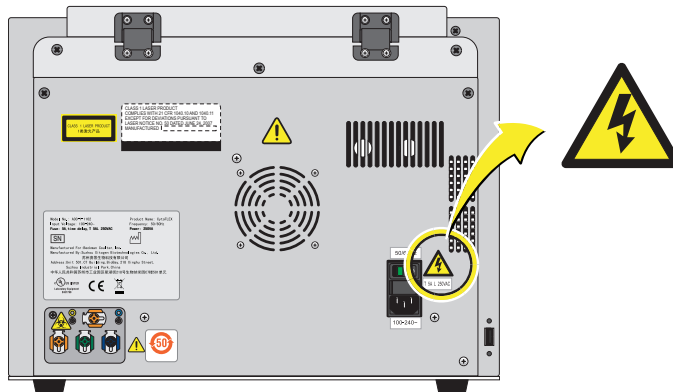

Figure 9.5 Biohazard Label Located in the Sample Station and on the Back of the Cytometer



Electrical Shock Hazard Label and Location

Figure 9.6 Electrical Shock Hazard Label by the Power Switch



Caution Labels and Location

Figure 9.7 Caution Labels

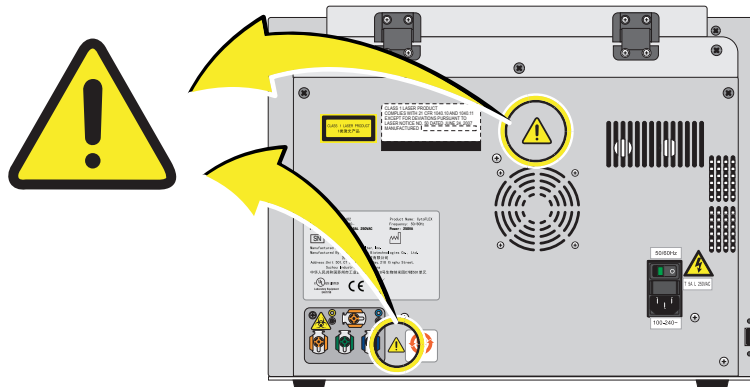
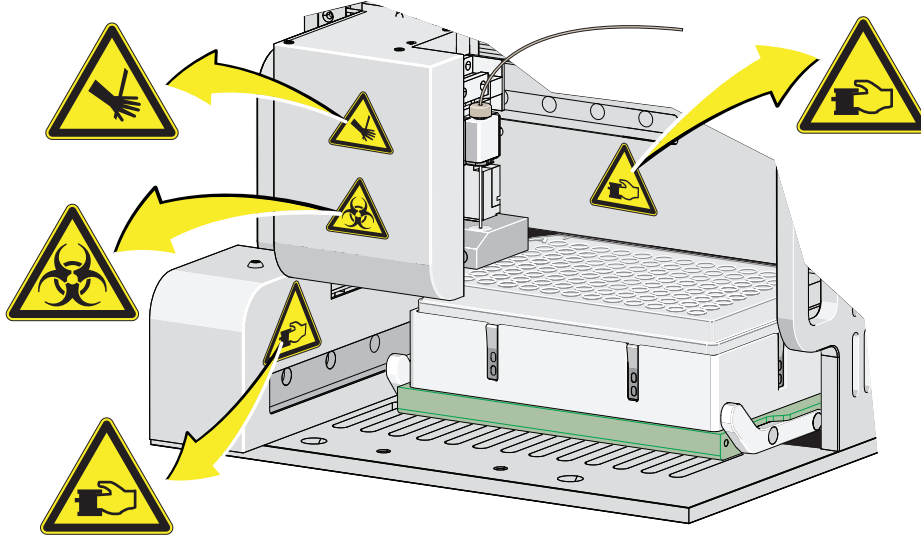

Plate Loader Hazard Labels and Location

Figure 9.8 Plate Loader Hazard Labels



Disposal Of Electrical Instrumentation

It is very important that customers understand and follow all laws regarding the safe and proper disposal of electrical instrumentation.

The symbol of a crossed-out wheeled bin on the product is required in accordance with the Waste Electrical and Electronic Equipment (WEEE) Directive of the European Union. The presence of this marking on the product indicates:

- that the device was put on the European Market after August 13, 2005 and
- that the device is not to be disposed via the municipal waste collection system of any member state of the European Union.

For products under the requirement of WEEE directive, please contact your dealer or local Beckman Coulter office for the proper decontamination information and take back program which will facilitate the proper collection, treatment, recovery, recycling, and safe disposal of device.

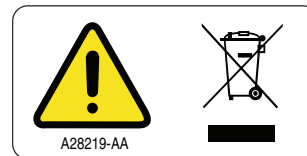

RoHS Notice

These labels and materials declaration table (the Table of Hazardous Substance's Name and Concentration) are to meet People's Republic of China Electronic Industry Standard SJ/T11364-2006 "Marking for Control of Pollution Caused by Electronic Information Products" requirements.

RoHS Caution Label

This label indicates that this electronic information product contains certain toxic or hazardous substances. The center number is the Environmentally friendly Use Period (EFUP) date, and indicates the number of calendar years the product can be in operation. Upon the expiration of the EFUP, the product must be recycled. The circling arrows indicate the product is recyclable. The date code on the label or product indicates the date of manufacture.



RoHS Environmental Label

This label indicates that the electronic information product does not contain any toxic or hazardous substances. The center "e" indicates the product is environmentally safe and does not have an Environmentally Friendly Use Period (EFUP) date. Therefore, it can safely be used indefinitely. The circling arrows indicate the product is recyclable. The date code on the label or product indicates the date of manufacture.

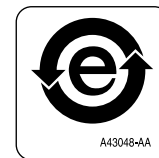

Disposal Precaution



Risk of biohazardous contamination if you have skin contact with the waste container, its contents, and its associated tubing. The waste container and its associated tubing could contain residual biological material and must be handled with care. Clean up spills immediately. Dispose of the contents of the waste container in accordance with your local regulations and acceptable laboratory procedures.

Use universal precautions when working with pathogenic materials. Means must be available to decontaminate the instrument and to dispose of biohazardous waste.

Troubleshooting Table

Table 9.1 lists problems that you could encounter while running the CytoFLEX flow cytometer, the probable causes of each problem, and the corrective actions. These problems are listed alphabetically in the Index, under the primary entry “troubleshooting.”

Table 9.1 Troubleshooting

Problem	Probable Cause	Corrective Action
The Cytometer cannot be turned on.	<ul style="list-style-type: none"> The power cable is not securely connected. The fuse is blown. 	<ol style="list-style-type: none"> 1. Ensure that the power cable is securely connected to the back of the Cytometer. 2. Replace the fuse. Refer to CHAPTER 11, Replacing the Fuse in CHAPTER 11, Replacement/Adjustment Procedures. 3. If the problem persists, contact your Beckman Coulter Representative.
The Workstation cannot be turned on.	<ul style="list-style-type: none"> The power cable is not securely connected. The Workstation was restarted too fast. 	<ol style="list-style-type: none"> 1. Ensure that the power cable is securely connected to the back of the Cytometer. 2. Unplug the power cable. Wait 10 seconds, then plug the power cable back in. Then, restart the computer. 3. If the problem persists, contact your Beckman Coulter Representative.
The connection indicator light in the lower left corner of the software screen is red and displays <i>Disconnected and Error</i> .	<ul style="list-style-type: none"> Data connection error The Cytometer is not turned on. The Cytometer’s power cable is disconnected. 	<ol style="list-style-type: none"> 1. Ensure that the USB data cable is securely connected to the back of the Cytometer and the back of the Workstation. Refer to Figure 1.14. 2. Restart the software. Restart the Workstation. Refer to Initializing the Instrument in CHAPTER 3, Daily Startup. 3. Turn on the Cytometer using the power switch on the back of the instrument. 4. Verify that the power cable is securely connected to the back of the Cytometer. 5. If the problem persists, contact your Beckman Coulter Representative.
The alarm does not sound when the waste container is full or the sheath fluid container is low and the software status display is red.	<ul style="list-style-type: none"> The alarm is not working. Instrument data connection error. 	<ol style="list-style-type: none"> 1. Ensure that the USB data cable is securely connected to the back of the Cytometer and the back of the Workstation. Refer to Figure 1.14. 2. Restart the Workstation. Refer to Initializing the Instrument in CHAPTER 3, Daily Startup. 3. Restart the software. 4. If the problem persists, contact your Beckman Coulter Representative.

Table 9.1 Troubleshooting (*Continued*)

Problem	Probable Cause	Corrective Action
<p>The fluid status information displays red for <i>Sheath</i> and/or <i>Waste</i> even though the sheath fluid container is full and the waste container is empty.</p>	<ul style="list-style-type: none"> • Instrument data connection error. • The sensor connection is not working properly. • The sensor does not work properly. 	<ol style="list-style-type: none"> 1. Ensure that the USB data cable is securely connected to the back of the Cytometer and the back of the Workstation. Refer to Figure 1.14. 2. Restart the software. 3. Ensure the sheath fluid harness and/or the waste harness are properly connected. 4. Verify that the float of the sensor in the sheath fluid container and/or waste container moves freely. 5. Replace the sheath fluid harness and/or the waste harness. Refer to Replacing the Sheath Fluid Harness and/or Waste Harness in CHAPTER 11, Replacement/Adjustment Procedures. 6. If the problem persists, contact your Beckman Coulter Representative.
<p>The sample tube holder cannot move up and down automatically.</p>	<p>The setting is incorrect.</p>	<ol style="list-style-type: none"> 1. Ensure that the sample injection mode in the software is in Semi-Automatic Injection mode. Refer to Selecting the Proper Sample Injection Mode in CHAPTER 3, Daily Startup. 2. If the problem persists, contact your Beckman Coulter Representative.

Table 9.1 Troubleshooting (*Continued*)

Problem	Probable Cause	Corrective Action
The sample flow rate is unstable.	<ul style="list-style-type: none"> • The sample probe is clogged. • The sample contains aggregates or clumps. • There are air bubbles in the flow cell. • The sample peristaltic pump tubing is aged. • The sample peristaltic pump tubing is not properly connected. 	<ol style="list-style-type: none"> 1. Run Prime. Refer to Priming the Flow Cell in CHAPTER 11, Replacement/Adjustment Procedures. 2. Run Daily Clean. Refer to Daily Clean in CHAPTER 10, Cleaning Procedures. 3. Clean the sample probe. Refer to Cleaning the Sample Probe in CHAPTER 10, Cleaning Procedures. 4. Filter the sample using an appropriately sized mesh aperture filter. 5. Ensure that the sample tubing is properly connected. Refer to Replacing the Sample Probe and/or the Sample Peristaltic Pump Tubing in CHAPTER 11, Replacement/Adjustment Procedures. 6. Replace the sample probe and sample peristaltic pump tubing. Refer to Replacing the Sample Probe and/or the Sample Peristaltic Pump Tubing in CHAPTER 11, Replacement/Adjustment Procedures. 7. If the problem persists, contact your Beckman Coulter Representative.
The sampling flow rate is too fast.	<ul style="list-style-type: none"> • The threshold setting is too low. • The sample concentration is too high. • There are too many sample fragments. • The sheath fluid filter is clogged. 	<ol style="list-style-type: none"> 1. Use the manual threshold setting to increase the threshold. Refer to Adjusting the Threshold in CHAPTER 5, Data Acquisition and Sample Analysis. 2. Dilute the sample and adjust the concentration to approximately 10^6/mL. 3. Filter the sample using an appropriately sized mesh aperture filter. 4. Restain the sample. 5. Replace the Sheath Fluid Filter. Refer to Replacing the Sheath Fluid Filter in CHAPTER 11, Replacement/Adjustment Procedures. 6. If the problem persists, contact your Beckman Coulter Representative.
Laser power is low.	Communication error	<ol style="list-style-type: none"> 1. Reinitialize. Refer to Initializing the Instrument in CHAPTER 3, Daily Startup. 2. Restart the Cytometer. 3. If the problem persists, contact your Beckman Coulter Representative.

Table 9.1 Troubleshooting (Continued)

Problem	Probable Cause	Corrective Action
Populations are drifting.	<ul style="list-style-type: none"> • Air bubbles are in the flow cell. • Air bubbles are in the system. • The sheath fluid harness float is restricted. 	<ol style="list-style-type: none"> 1. Run Prime. Refer to Priming the Flow Cell in CHAPTER 11, Replacement/Adjustment Procedures. 2. Ensure that the sheath fluid harness and/or waste harness is not kinked. 3. Ensure that the sheath fluid harness and/or waste harness is securely connected. 4. Run Prime. Refer to Priming the Flow Cell in CHAPTER 11, Replacement/Adjustment Procedures. 5. Verify that the float of the sensor in the sheath fluid container moves freely. 6. Replace the sheath fluid harness. Refer to Replacing the Sheath Fluid Harness and/or Waste Harness in CHAPTER 11, Replacement/Adjustment Procedures. 7. If the problem persists, contact your Beckman Coulter Representative.
Population amplitude is decreasing and CV values are increasing.	<ul style="list-style-type: none"> • Air bubbles are in the flow cell. • The flow cell is dirty. • The sheath fluid harness float is restricted. 	<ol style="list-style-type: none"> 1. Run Prime. Refer to Priming the Flow Cell in CHAPTER 11, Replacement/Adjustment Procedures. 2. Run the Deep Clean procedure. Refer to Deep Clean Procedure in CHAPTER 10, Cleaning Procedures. 3. Verify that the float of the sensor in the sheath fluid container moves freely. 4. Replace the sheath fluid harness. Refer to Replacing the Sheath Fluid Harness and/or Waste Harness in CHAPTER 11, Replacement/Adjustment Procedures. 5. If the problem persists, contact your Beckman Coulter Representative.
The laser delay values are out of range.	<ul style="list-style-type: none"> • Air bubbles are in the flow cell. • Air bubbles are in the system. • The sheath fluid harness float is restricted. 	<ol style="list-style-type: none"> 1. Run Prime. Refer to Priming the Flow Cell in CHAPTER 11, Replacement/Adjustment Procedures. 2. Ensure that the sheath fluid harness and/or waste harness is not kinked. 3. Ensure that the sheath fluid harness and/or waste harness is securely connected. 4. Verify that the float of the sensor in the sheath fluid container moves freely. 5. Replace the sheath fluid harness. Refer to Replacing the Sheath Fluid Harness and/or Waste Harness in CHAPTER 11, Replacement/Adjustment Procedures. 6. If the problem persists, contact your Beckman Coulter Representative.

Table 9.1 Troubleshooting (*Continued*)

Problem	Probable Cause	Corrective Action
No data acquisition.	<ul style="list-style-type: none"> • The threshold setting is too high. • The gain setting is too low. • Sheath fluid flow is insufficient. • Laser power is insufficient. • The sample probe is clogged. 	<ol style="list-style-type: none"> 1. Decrease the threshold setting. Refer to Adjusting the Threshold in CHAPTER 5, Data Acquisition and Sample Analysis. 2. Increase the gain setting. Refer to Adjusting the Gain in CHAPTER 5, Data Acquisition and Sample Analysis. 3. Ensure that the sheath fluid harness and/or waste harness is not kinked. 4. Ensure that the sheath fluid harness and/or waste harness is securely connected. 5. Run Prime. Refer to Priming the Flow Cell in CHAPTER 11, Replacement/Adjustment Procedures. 6. Reinitialize. Refer to Initializing the Instrument in CHAPTER 3, Daily Startup. 7. Restart the Cytometer. 8. Verify that your sample does not have excessive debris. If it does: <ol style="list-style-type: none"> a. Filter the sample using an appropriately sized mesh aperture filter. b. Restain the sample. 9. Clean the sample probe. Refer to Cleaning the Sample Probe in CHAPTER 10, Cleaning Procedures. 10. Replace the sample probe and the sample peristaltic pump tubing. Refer to Replacing the Sample Probe and/or the Sample Peristaltic Pump Tubing in CHAPTER 11, Replacement/Adjustment Procedures. 11. If the problem persists, contact your Beckman Coulter Representative.
Data populations are normal on one laser, but too low on another laser.	The laser delay setting is incorrect.	<ol style="list-style-type: none"> 1. Ensure that the laser delay is set correctly. Refer to Setting Laser Delay in CHAPTER 11, Replacement/Adjustment Procedures. 2. If the problem persists, contact your Beckman Coulter Representative.

Table 9.1 Troubleshooting (*Continued*)

Problem	Probable Cause	Corrective Action
Data populations are not where they are expected.	<ul style="list-style-type: none"> • The detector configuration setting is incorrect. • The optical filter is not placed correctly. • QC was not completed. • Gain and threshold is not set correctly. 	<ol style="list-style-type: none"> 1. Ensure that the detector configuration is set correctly. Refer to Verifying, Selecting, Editing, and Creating Detector Configuration in CHAPTER 5, Data Acquisition and Sample Analysis. 2. Ensure that the position of the optical filter in the WDM matches the detector configuration setting. Refer to Verifying, Selecting, Editing, and Creating Detector Configuration in CHAPTER 5, Data Acquisition and Sample Analysis. 3. Ensure that the optical filter is installed correctly. Refer to Replacing the Optical Filter in CHAPTER 11, Replacement/ Adjustment Procedures. 4. Follow the QC procedure. Refer to CHAPTER 4, Instrument Quality Control. 5. Review the gain and threshold settings. Refer to Adjusting the Gain and Adjusting the Threshold in CHAPTER 5, Data Acquisition and Sample Analysis. 6. Review the display ranges. Refer to Creating Plots and Gates in CHAPTER 5, Data Acquisition and Sample Analysis. 7. If the problem persists, contact your Beckman Coulter Representative.
No changes occurred after manually adjusting compensation settings.	Compensation was applied to the wrong channel.	<p>Ensure that the adjustment is applied to the correct primary and secondary channels in the compensation matrix.</p> <p>Or</p> <p>Select  to modify compensation in the desired plot.</p>

Table 9.1 Troubleshooting (*Continued*)



Problem	Probable Cause	Corrective Action
<p>The calculation of the automatic compensation experiment is incorrect.</p>	<ul style="list-style-type: none"> • Erroneous data acquisition. • The gate is not set on the appropriate population. • The events of the acquired cells are too low. • The mean fluorescence of the positive cells is too weak. 	<ol style="list-style-type: none"> 1. Ensure that the corresponding negative control tube and the individual positive tube acquired are from the same sample type. 2. Ensure that the single colors collected correspond to the correct tube name. 3. Ensure that the gate in the FSC/SSC plot encloses the correct sample population. 4. Ensure that the positive gate in each tube is correctly placed. 5. Modify the events to record to ensure that enough events are collected for the data population. 6. Select samples with a stronger positive signal as the positive control. <p>Or</p> <p>Use dedicated compensation beads such as VersaComp Antibody Capture Beads</p>
<p>The sample is flowing, but no signal appears in the plot.</p>	<ul style="list-style-type: none"> • The signal is outside of the display range. • The parent gate is not positioned properly and does not contain events. • The population color setting is too light. • The threshold is too high. 	<ol style="list-style-type: none"> 1. Use either  or  to modify the display range. <p>Or</p> <p>Right-click the plot and select Property. The Plot Property window appears. Select Fit with sample.</p> <ol style="list-style-type: none"> 2. Ensure that the parent gate is gated correctly. 3. Change the display color. 4. Move the sample above the threshold using one of the following methods: <ul style="list-style-type: none"> • Decrease the threshold setting. Refer to Adjusting the Threshold in CHAPTER 5, Data Acquisition and Sample Analysis. • Increase the gain setting. Refer to Adjusting the Gain in CHAPTER 5, Data Acquisition and Sample Analysis.

Table 9.1 Troubleshooting (*Continued*)

Problem	Probable Cause	Corrective Action
<p>The concentration calculation is incorrect.</p>	<ul style="list-style-type: none"> • The sample concentration is not within the specified range. • The sample settled. • The sample flow rate is too fast. • The sample volume analyzed is too low. • The cell population is not detected. 	<ol style="list-style-type: none"> 1. Ensure that the pipette used in sample processing is calibrated. 2. Verify that the concentration of the sample is between 2×10^4-10^7 events/mL. 3. Vortex the sample before loading and verify that the sample is evenly mixed before loading the sample. <p style="margin-left: 20px;">NOTE An excessively long sample loading time leads to sample settlement.</p> 4. Ensure that the sample flow rate does not exceed 10,000 events/second. 5. Adjust the threshold to remove sample debris. 6. Ensure that the sample volume analyzed exceeds 10 μL. 7. Ensure that the following are correct: <ul style="list-style-type: none"> • Gain. Refer to Adjusting the Gain in CHAPTER 5, Data Acquisition and Sample Analysis. • Threshold. Refer to Adjusting the Threshold in CHAPTER 5, Data Acquisition and Sample Analysis. • Compensation settings. Refer to CHAPTER 6, Compensation 8. Ensure that the gating and population hierarchy are correct.
<p>The sample probe is too low.</p>	<p>The sample probe is not securely connected.</p>	<ol style="list-style-type: none"> 1. Ensure that the sample probe is securely connected to the sample peristaltic pump tubing. Refer to Replacing the Sample Probe and/or the Sample Peristaltic Pump Tubing in CHAPTER 11, Replacement/Adjustment Procedures. 2. Ensure the sample pump cover is securely fastened. 3. If the problem persists, contact your Beckman Coulter Representative.

Table 9.1 Troubleshooting (*Continued*)

Problem	Probable Cause	Corrective Action
The wash station drips during backflush.	<ul style="list-style-type: none"> The sample probe is not securely connected. The wash station height adjustment is not correct. 	<ol style="list-style-type: none"> Ensure that the sample probe is securely connected to the sample peristaltic pump tubing. Refer to Replacing the Sample Probe and/or the Sample Peristaltic Pump Tubing in CHAPTER 11, Replacement/Adjustment Procedures. Ensure the sample pump cover is securely fastened. If the problem persists, contact your Beckman Coulter Representative.
The mixer is not functioning.	<ul style="list-style-type: none"> Sample mixing is disabled in the software. The mixer motor is defective. 	<ol style="list-style-type: none"> Ensure sample mixing is enabled in the software. Refer to Changing Sample Mixing and Backflush Settings in CHAPTER 11, Replacement/Adjustment Procedures. If the problem persists, contact your Beckman Coulter Representative.
Instrument operations cannot be performed in the Acquisition screen.	<ul style="list-style-type: none"> The instrument is in standby mode. The software is frozen. Data connection error. 	<ol style="list-style-type: none"> Select Initialize. Ensure that the power switch to the Cytometer is turned on. Restart the software. Restart the Workstation. Ensure that the USB data cable is securely connected to the back of the Cytometer and the back of the Workstation. Refer to Figure 1.14. If the problem persists, contact your Beckman Coulter Representative.
Software installation fails.	Multiple issues.	Contact your Beckman Coulter Representative.

Table 9.1 Troubleshooting (*Continued*)

Problem	Probable Cause	Corrective Action
<p>QC aborted due to low event rate.</p>	<ul style="list-style-type: none"> • The diluted CytoFLEX Daily QC Fluorosphere concentration is too low. • The sample probe is clogged. • The sample line is clogged. 	<ol style="list-style-type: none"> 1. Add 1 drop of CytoFLEX Daily QC Fluorospheres to the QC solution. Then, rerun QC. 2. Reload the target value file. Refer to Importing Lot-Specific Target Values in CHAPTER 4, Instrument Quality Control. Then, rerun QC. 3. Prepare a new sample of the CytoFLEX Daily QC Fluorospheres. Then, rerun QC. 4. Clean the sample probe. Refer to Cleaning the Sample Probe in CHAPTER 10, Cleaning Procedures. Then, rerun QC. 5. Run Prime. Refer to Priming the Flow Cell in CHAPTER 11, Replacement/Adjustment Procedures. Then, rerun QC. 6. Run Daily Clean. Refer to Daily Clean in CHAPTER 10, Cleaning Procedures. Then, rerun QC. 7. Replace the sample probe and sample peristaltic pump tubing. Refer to Replacing the Sample Probe and/or the Sample Peristaltic Pump Tubing in CHAPTER 11, Replacement/Adjustment Procedures. Then, rerun QC. 8. If problem persists, contact your Beckman Coulter Representative.

Table 9.1 Troubleshooting (*Continued*)

Problem	Probable Cause	Corrective Action
QC failed.	<ul style="list-style-type: none"> • The median fluorescence fails to meet the target specification. • The QC gain value does not meet the target gain specifications. • The laser delay settings are too high. • rCV fails specifications. 	<ol style="list-style-type: none"> 1. Rerun QC. Refer to CHAPTER 4, Instrument Quality Control. 2. Run Prime. Refer to Priming the Flow Cell in CHAPTER 11, Replacement/Adjustment Procedures. Then, rerun QC. 3. Prime the sheath fluid filter with sheath fluid as follows, then rerun QC. <ol style="list-style-type: none"> a. Remove the vent cap from the sheath fluid filter. b. Remove the rubber insert from the vent. c. Ensure that the instrument is in Standby. d. At the Workstation, select Cytometer > Prime. <p>IMPORTANT If the rubber insert and the vent cap are not reinstalled as soon as the sheath fluid approaches the vent port, the sheath fluid will overflow.</p> <ol style="list-style-type: none"> e. Wait until the sheath fluid approaches the vent port in the sheath fluid filter, then immediately reinstall the rubber insert and the vent cap to avoid overflow. 4. Run Daily Clean. Refer to Daily Clean in CHAPTER 10, Cleaning Procedures. Then, rerun QC. 5. Run Deep Clean. Refer to Deep Clean Procedure in CHAPTER 10, Cleaning Procedures. Then, rerun QC. 6. If the problem persists, contact your Beckman Coulter Representative.

Table 9.2 Troubleshooting [With Plate Loader]

Problem	Probable Cause	Corrective Action
The sample probe comes in contact with the bottom of the well plate.	<ul style="list-style-type: none"> • Incorrect plate type selected. • The plate or plate holder is installed incorrectly. • The sample probe sampling position is not calibrated. 	<ol style="list-style-type: none"> 1. Verify that the correct plate type is selected in the Plate window. 2. Ensure the plate and the plate holder are installed correctly. Refer to Replacing the Plate Holder [With Plate Loader] in CHAPTER 11, Replacement/Adjustment Procedures. 3. Calibrate the sample probe sampling position. Refer to Calibrating the Plate Position [With Plate Loader] in CHAPTER 11, Replacement/Adjustment Procedures.
The dead volume of the plate wells are high.	<ul style="list-style-type: none"> • Incorrect plate type selected. • The sample probe sampling position is not calibrated. 	<ol style="list-style-type: none"> 1. Verify that the correct plate type is selected in the Plate window. 2. Calibrate the sample probe sampling position. Refer to Calibrating the Plate Position [With Plate Loader] in CHAPTER 11, Replacement/Adjustment Procedures.
Mixing does not sufficiently suspend the sample particles.	<ul style="list-style-type: none"> • Incorrect plate type selected. • Incorrect sample mixing setting. • The sample probe sampling position is not calibrated. 	<ol style="list-style-type: none"> 1. Verify that the correct plate type is selected in the Plate window. 2. Verify the sample mixing duration in the Plate window. 3. Calibrate the sample probe sampling position. Refer to Calibrating the Plate Position [With Plate Loader] in CHAPTER 11, Replacement/Adjustment Procedures.

Overview

This chapter describes how to carry out certain routine and nonscheduled cleaning procedures. Proper cleaning can help extend the service life of the instrument and ensure experimental accuracy. When conducting any cleaning, take all necessary biosafety precautions and use proper personal protective equipment.

This chapter contains information on:

- [Routine Cleaning](#)
 - [Daily Clean](#)
 - [Daily Clean \[With Plate Loader\]](#)
 - [Cleaning the Sample Station](#)
 - [Deep Clean Procedure](#)
 - [Cleaning the Sheath Fluid Container](#)
 - [Cleaning the Waste Container](#)
- [Nonscheduled Cleaning](#)
 - [Preparing the Instrument for Transport or Storage](#)

Routine Cleaning

Daily Clean

Daily Clean should be performed during instrument startup and instrument shutdown to clean the sample line.

After sampling an excessively large sample or a sample that can easily clog the sample probe, it is recommended to perform the Daily Clean procedure. Daily Clean can also be used to remove residual sample from previous tubes.

- 1 Open the CytExpert software and confirm that the instrument is connected and that it has already been initialized. Refer to [Opening the Software](#) in [CHAPTER 3, Daily Startup](#).

- 2 Select **Daily Clean** in the Cytometer menu.

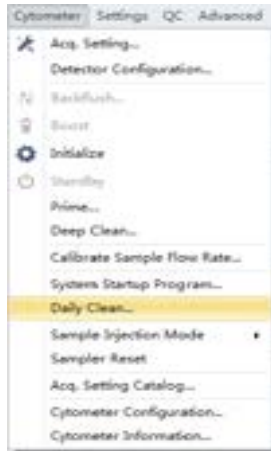

- 3 Add 2 mL of FlowClean solution to an unused sample tube.

- 4 Add 2 mL of DI water to an unused sample tube.

- 5 Insert the sample tube with 2 mL of FlowClean solution into the sample holder and select **Run**.

NOTE The default cleaning time is 3 minutes.

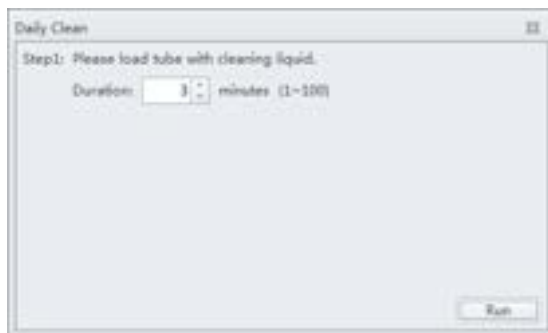

6 Remove the Flow Clean tube.

7 Insert the sample tube with 2 mL of DI water into the sample holder and select **Run** to perform the second step of the cleaning process.

NOTE The default cleaning time is 5 minutes.

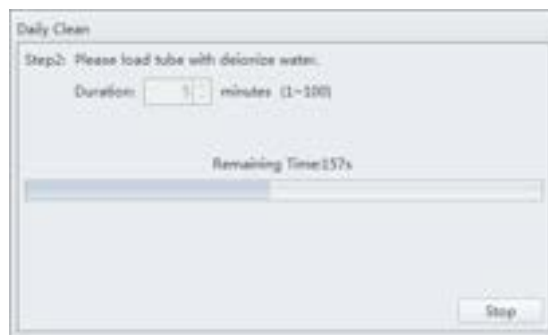

8 After the process has been completed, remove the sample tube and close the Daily Clean window.



Daily Clean [With Plate Loader]

Daily Clean should be performed during instrument startup and instrument shutdown to clean the sample line.

After sampling an excessively large sample or a sample that can easily clog the sample probe, it is recommended to perform the Daily Clean procedure. Daily Clean can also be used to remove residual sample from previous tubes.

- 1 Open the CytExpert software and confirm that the instrument is connected and that it has already been initialized. Refer to [Opening the Software](#) in [CHAPTER 3, Daily Startup](#).
- 2 Select **Daily Clean** in the Cytometer menu. The Daily Clean window appears. The plateloader automatically ejects the plate holder stage.

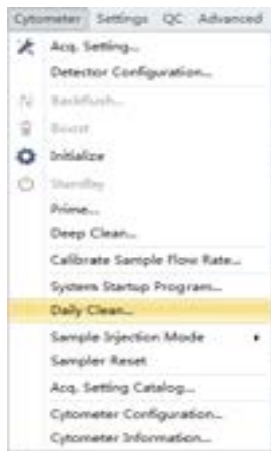

- 3 Follow the on screen software prompts and select the desired wells for cleaning agent and deionized water.



IMPORTANT You must select at least one cleaning solution well and one water well.

- a. Select the desired wells for the cleaning agent and select **Set As Cleaning Agent Well**.
- b. Select the desired wells for the deionized water and select **Set As Deionized Water Well**.

NOTE To deselect water wells, select the desired well and select **Set As Empty Well**.

- 4 Select **Load** to load the plate.
- 5 Select **Start** to start the cleaning procedure. The message *Please confirm that the correct plate is placed properly and press OK* appears. Select **OK**.
- 6 Select **Close**.

Cleaning the Sample Station

Carry out semi-automatic cleaning for the sample injection device once a week.

- 1 Ensure that the system has been shut down properly. Refer to [Shutting Down the Instrument](#) in CHAPTER 8, Daily Shutdown.

 **WARNING**

Risk of chemical injury from bleach. To avoid contact with the bleach, use barrier protection, including protective eyewear, gloves, and suitable laboratory attire. Refer to the Safety Data Sheet for details about chemical exposure before using the chemical.

- 2 Use a piece of soft cloth with a 10% bleach solution (1 part bleach [5 to 6% sodium hypochlorite - available chlorine] with 9 parts DI water) to wipe off all surfaces in the sample station, while taking all necessary biological safety precautions.

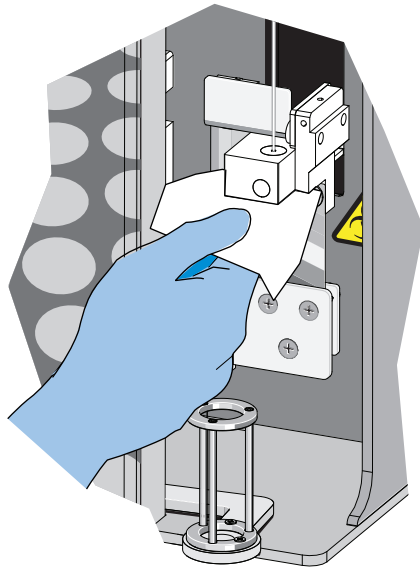

- 3 Wipe off the bottom of the semi-automatic sample injection device.

Cleaning the Sample Probe

When problems such as blockage of the sample probe occur, it is required to replace or clean the sample probe.

- 1 Confirm that the instrument is in the standby state or that the power supply is turned off.

**WARNING**

Risk of biohazardous contamination if you have skin contact with the sample probe or the sample peristaltic pump tubing. The sample probe and the sample peristaltic pump tubing might contain residual biological material and must be handled with care. Clean up spills immediately. Dispose of the sample probe and the sample peristaltic pump tubing in accordance with your local regulations and acceptable laboratory procedures.

2 Remove the sample probe. Refer to [Replacing the Sample Probe and/or the Sample Peristaltic Pump Tubing](#) in CHAPTER 11, Replacement/Adjustment Procedures.

3 Put the sample probe into a clean container and soak it in clean water. Use an ultrasonic cleaning device to clean for 2 minutes.

4 Reattach the sample probe to the sample peristaltic pump tubing, and confirm that the bead on the sample probe touches the sleeve on the end of the sample peristaltic pump tubing.

IMPORTANT To ensure that the proper placement of the sample probe, push the sample pump cover up while installing the thumbscrew.

5 Install the sample pump cover.

6 If ineffective, replace with a new sample probe. Refer to [Replacing the Sample Probe and/or the Sample Peristaltic Pump Tubing](#) in CHAPTER 11, Replacement/Adjustment Procedures.

Deep Clean Procedure

Carry out a deep clean once a month to clean the instrument flow cell. If the unit will be shutdown and not used for more than 10 days, it is recommended to complete one deep clean before resuming use.

1 Place the instrument in standby state.

2 Remove the right-side cover. Refer to [Right-Side Cover Removal and Reinstallation](#) in CHAPTER 11, Replacement/Adjustment Procedures.

-
- 3 Confirm that the Deep Clean solution volume in the bottle located inside the Fluidics module is sufficient.

To prepare and add more Deep Clean solution, refer to [Adding the Deep Clean Solution](#) in CHAPTER 11, Replacement/Adjustment Procedures.

-
- 4 Select **Deep Clean** in the Cytometer menu. The software message *Are you sure to start deep clean?* appears. Select **Yes** to start the Deep Clean process in the instrument flow cell.

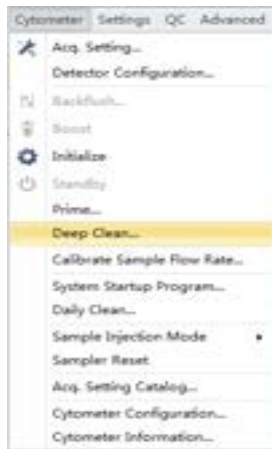

-
- 5 The status bar prompts that a deep clean is under way. Wait for the Deep Clean process to finish. The following software message appears:

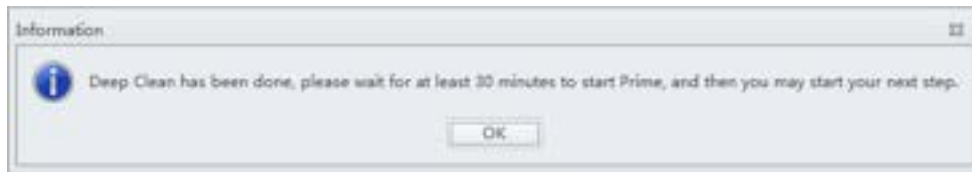

Select **OK**.

-
- 6 Allow the cleaning solution to remain in the flow cell for approximately 30 minutes. If you are required to postpone the cleaning time, do not exceed 24 hours. During the Deep Clean cycle, the power supply of the unit can be turned off, but the instrument cannot be initialized.

- 7 Select **Prime** in the Cytometer menu. The software message *Are you sure to start Prime?* appears. Select Yes.

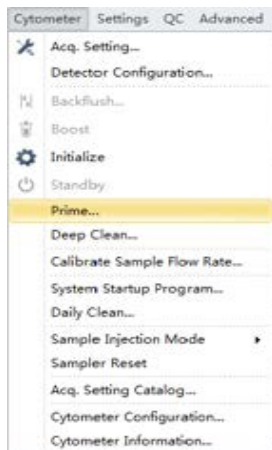

- 8 Run Daily Clean. Refer to [Daily Clean](#).
- 9 Perform initialization as required (see [Initializing the Instrument](#) in [CHAPTER 3, Daily Startup](#)) to carry out the next experiment or to turn off the instrument.
- 10 Reinstall the right-side cover. Refer to [Right-Side Cover Removal and Reinstallation](#) in [CHAPTER 11, Replacement/Adjustment Procedures](#).

Cleaning the Sheath Fluid Container

Clean the sheath fluid container once a month.

- 1 Confirm that the instrument is turned off or is in the standby state.
- 2 Remove the sheath fluid container from the Fluid Container holder.
- 3 Remove the sheath fluid harness from the sheath fluid container.
- 4 Empty the residual sheath fluid from the sheath fluid container.
- 5 Add about 50 to 100 mL of CytoFLEX Sheath Fluid to the sheath fluid container.

-
- 6 Insert the sheath fluid harness back into the sheath fluid container and tightly close the sheath fluid container cap.

 - 7 Swirl the sheath fluid in the sheath fluid container, rinsing all surfaces.

 - 8 Empty the sheath fluid container.

 - 9 Refill the sheath fluid container. Refer to [Filling the Sheath Fluid Container](#) in [CHAPTER 11, Replacement/Adjustment Procedures](#).
-

Cleaning the Waste Container

Clean the waste container once a month.

-
- 1 Confirm that the instrument is turned off or is in the standby state.

 - 2 Remove the waste container from the Fluid Container holder.
-

 **WARNING**

Risk of biohazardous contamination if you have skin contact with the waste container, its contents, and its associated tubing. The waste container and its associated tubing could contain residual biological material and must be handled with care. Clean up spills immediately.

- 3 Remove the harness from the waste container.
-

 **WARNING**

Risk of biohazardous contamination if you have skin contact with the waste container, its contents, and its associated tubing. The waste container and its associated tubing could contain residual biological material and must be handled with care. Clean up spills immediately. Dispose of the contents of the waste container in accordance with your local regulations and acceptable laboratory procedures.

- 4 Empty the waste container.

⚠ WARNING

Risk of chemical injury from bleach. To avoid contact with the bleach, use barrier protection, including protective eyewear, gloves, and suitable laboratory attire. Refer to the Safety Data Sheet for details about chemical exposure before using the chemical.

- 5 Add one liter of sodium hypochlorite solution with 0.5% active chlorine to the waste container.
- 6 Insert the waste harness back into the waste container and tightly close the waste container cap.

⚠ CAUTION

Risk of damage to the sheath fluid harness and/or waste harness. Do not leave the sodium hypochlorite solution in the fluid containers longer than 10 minutes.

- 7 Let stand for 5 to 10 minutes.

⚠ WARNING

Risk of chemical injury from bleach. To avoid contact with the bleach, use barrier protection, including protective eyewear, gloves, and suitable laboratory attire. Refer to the Safety Data Sheet for details about chemical exposure before using the chemical.

- 8 Dispose of the sodium hypochlorite solution in accordance with your local regulations and acceptable laboratory procedures.
- 9 Use deionized water to rinse the waste container and the waste harness. Ensure that there is no sodium hypochlorite residue.
- 10 Place the waste container back into the Fluid Container holder.

Nonscheduled Cleaning

Preparing the Instrument for Transport or Storage

When the instrument is to be transported or is not to be used for 30 days or more, complete the emptying processes to prevent instrument damage and to reduce the possibility of biological contamination. Contact your Beckman Coulter Representative if you have any questions.

- 1 Run the Deep Clean procedure. Refer to [Deep Clean Procedure](#).
- 2 Run the Daily Clean procedure. Refer to [Daily Clean](#).
- 3 Clean the Sample Station. Refer to [Cleaning the Sample Station](#).
- 4 Empty the sheath fluid container and the waste container (see [Emptying the Waste Container](#) in [CHAPTER 11, Replacement/Adjustment Procedures](#)).

 **WARNING**

Risk of biohazardous contamination if you have skin contact with the waste container, its contents, and its associated tubing. The waste container and its associated tubing could contain residual biological material and must be handled with care. Clean up spills immediately. Dispose of the contents of the waste container in accordance with your local regulations and acceptable laboratory procedures.

- 5 Clean the sheath fluid container and the waste container. Refer to [Cleaning the Sheath Fluid Container](#).
- 6 Remove the right-side cover (see [Right-Side Cover Removal and Reinstallation](#) in [CHAPTER 11, Replacement/Adjustment Procedures](#)).
- 7 Remove the Deep Clean solution bottle from the bracket, empty the Deep Clean solution bottle, and rinse with DI water. Then, attach the Deep Clean solution bottle to the bracket.
- 8 Remove the Plate Loader module if applicable (see [Plate Loader Module Removal and Reinstallation \[With Plate Loader\]](#) in [CHAPTER 11, Replacement/Adjustment Procedures](#)).
- 9 Power down and disconnect all the cables and sheath fluid and waste harnesses.

⚠ CAUTION

Risk of instrument damage. The Cytometer can suffer irreparable damage if it is exposed to subfreezing temperatures while it still contains liquid. Always drain the flow cell after cleaning the Cytometer if the Cytometer will be stored or transported in subfreezing temperatures.

⚠ WARNING

Risk of contamination from biohazardous material. Always wear PPE when performing this procedure as you can contact components with blood residue when handling the Fluidics module. Dispose of any absorbent materials used to collect or clean up leaks in accordance with the local regulations and acceptable laboratory procedures.

- 10 Disconnect the blue-labeled tubing from the pneumatic valve PV1 and hold the absorbent material under the disconnected tubing to collect any dripping liquid.

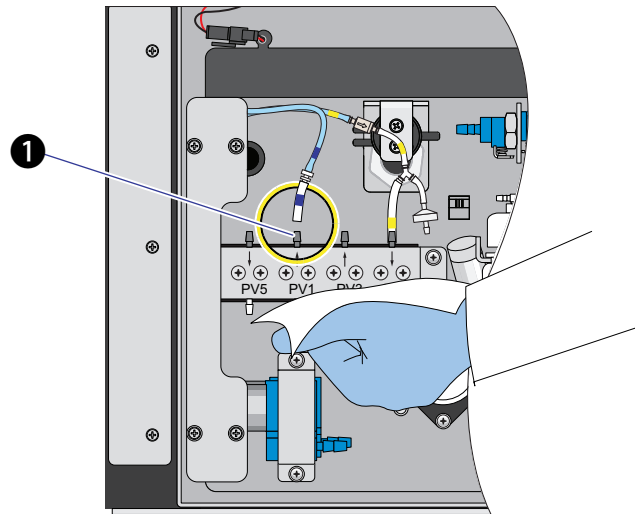

1. PV1

- 11 Disconnect the yellow-labeled tubing connected to the liquid damper to vent the flow cell, allowing it to drain.

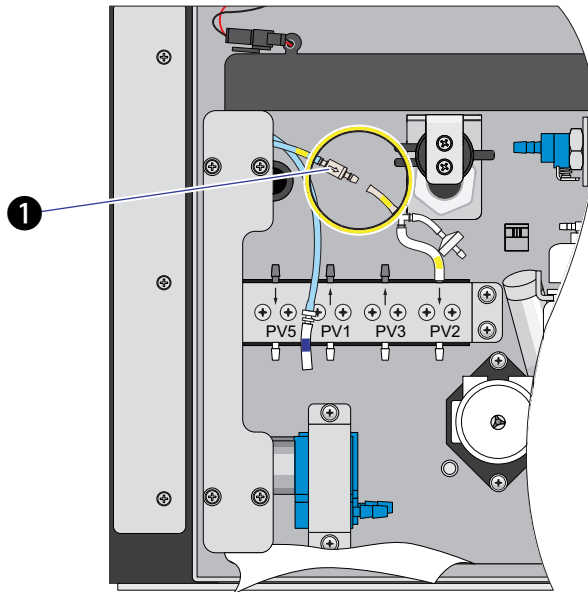

1. Liquid damper
- 12 Verify that liquid has stopped dripping from the blue-labeled tubing.
NOTE The flow cell is empty when liquid stops dripping from the blue-labeled tubing.
 - 13 Dispose of the absorbant material used to collect the liquid in accordance with the local regulations and acceptable laboratory procedures and cleanup any spills.
 - 14 Reconnect the blue-labeled tubing to PV1.
 - 15 Reconnect the yellow-labeled tubing to the liquid damper.
 - 16 Reinstall the right-side cover (see [Right-Side Cover Removal and Reinstallation](#) in [CHAPTER 11, Replacement/Adjustment Procedures](#)).
 - 17 Ensure that the optical filters are seated properly.
 - 18 Ensure that the top cover is tightly closed.

- 19** If the instrument is to be transported or stored, put the instrument and the Plate Loader module (if applicable) into the Beckman Coulter supplied packing and comply with the requirements in [Instrument Transportation and Storage](#) in [APPENDIX A, Instrument Installation](#), regarding correct placement during transportation and storage.

Lifting and Carrying Instructions

- 1** Position a person on the left and right sides of the Cytometer.
- 2** Reach under the base of the Cytometer in the areas indicated by the arrows in the figure below.

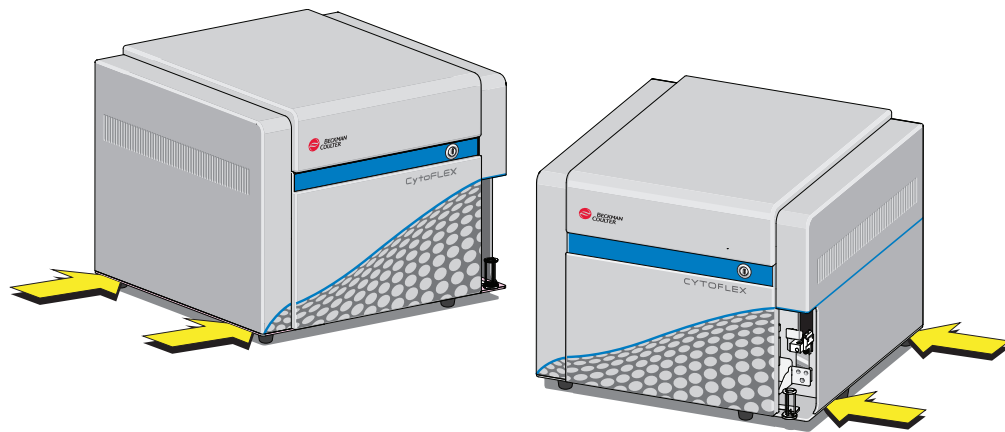

- 3** Gently lift the Cytometer as shown in the figure below.

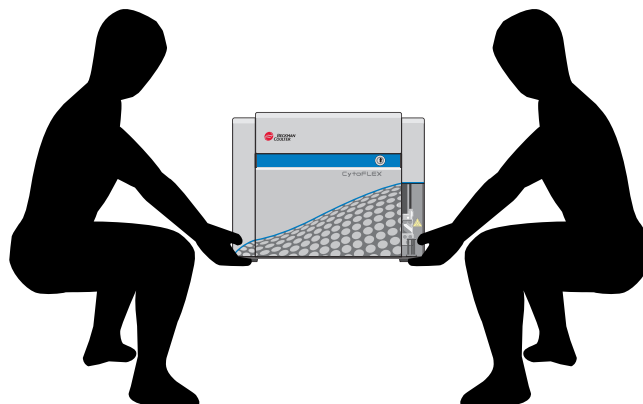

 **WARNING**

Risk of personal injury. Use caution when lowering the Cytometer to avoid pinching fingers.

- 4** Lower the Cytometer to its designated location.
-

Replacement/Adjustment Procedures

Overview

This chapter describes how to carry out certain routine and nonscheduled maintenance procedures. Proper maintenance can help extend the service life of the instrument and ensure experimental accuracy. When conducting any maintenance work, take all necessary biosafety precautions.

IMPORTANT In addition to parts specifically discussed, for all replacement parts, use only parts provided by Beckman Coulter to ensure proper functioning of the instrument. Never disassemble any part of the instrument without prior authorization. Beckman Coulter assumes no responsibility for any instrument problems resulting from the use of any part not authorized by Beckman Coulter for use with the instrument.

This chapter contains information on:

- Routine Replacement/Adjustment
 - Front Cover Removal and Reinstallation
 - Right-Side Cover Removal and Reinstallation
 - Filling the Sheath Fluid Container
 - Emptying the Waste Container
 - Managing the Maintenance Reminder
 - Adding the Deep Clean Solution
 - Replacing the Sheath Fluid Filter
 - Replacing the Sample Probe and/or the Sample Peristaltic Pump Tubing
 - Replacing the Sample Probe Assembly [With Plate Loader]
 - Changing the Sample Probe from the Single Tube Sample Station to the Plate Loader [With Plate Loader]
 - Changing the Sample Probe from the Plate Loader to the Single Tube Sample Station [With Plate Loader]
 - Inspecting the Liquid Flow Path for Leaks
 - Priming the Flow Cell
 - Replacing the Plate Holder [With Plate Loader]
 - Plate Loader Module Removal and Reinstallation [With Plate Loader]
 - Changing the Event Rate Setting
- Nonscheduled Replacement/Adjustment
 - Calibrating the Sample Flow Rate
 - Calibrating the Sample Flow Rate [With Plate Loader]
 - Setting Laser Delay

- Replacing the Optical Filter
- Replacing the Fuse
- Replacing the Sheath Fluid Harness and/or Waste Harness
- Changing Sample Mixing and Backflush Settings
- Calibrating the Plate Position [With Plate Loader]

Routine Replacement/Adjustment

Front Cover Removal and Reinstallation

Removal



Risk of personal injury from electric shock caused by contacting exposed electronic components. Power down the instrument before removing the front cover of the Cytometer.

- 1** Exit the system software.
- 2** Turn off the main power switch on the back of the Cytometer.
- 3** Open the top cover.

-
- 4** Remove the two screws securing the front cover and pull the front cover forward.

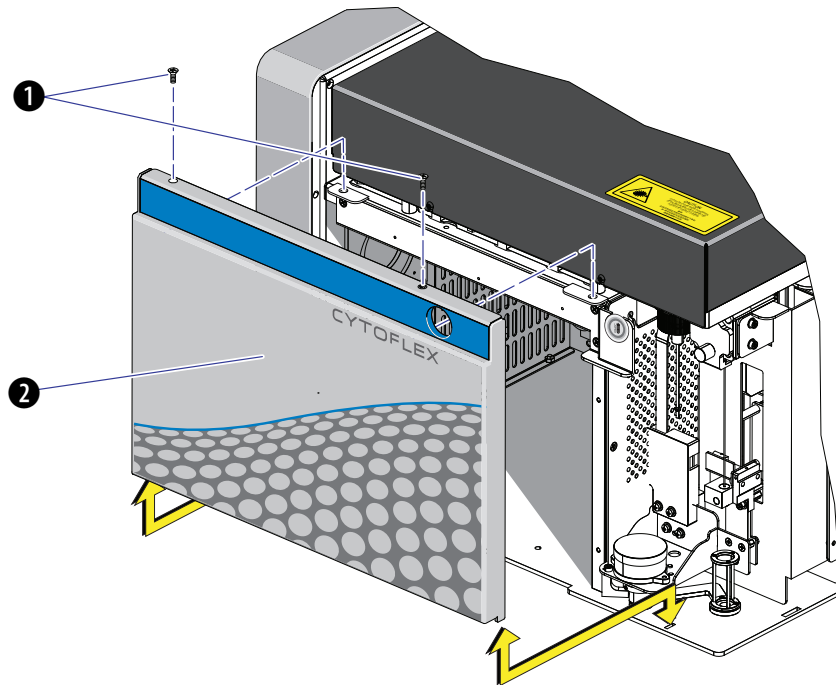

- 1. Securing screws
- 2. Front cover

-
- 5** Lift the front cover up and out of the slots in the frame.

Reinstallation

-
- 1** Slide the tabs on the bottom of the front cover into the slots in the bottom of the frame.
-
- 2** Push in the latches on the front cover to retract the pins, push the front cover into place, and release the latches to secure the cover.
-
- 3** Close the top cover.
-

Right-Side Cover Removal and Reinstallation

Removal

- 1 Open the top cover.
- 2 Unfasten the two captive thumbscrews for the right-side cover.

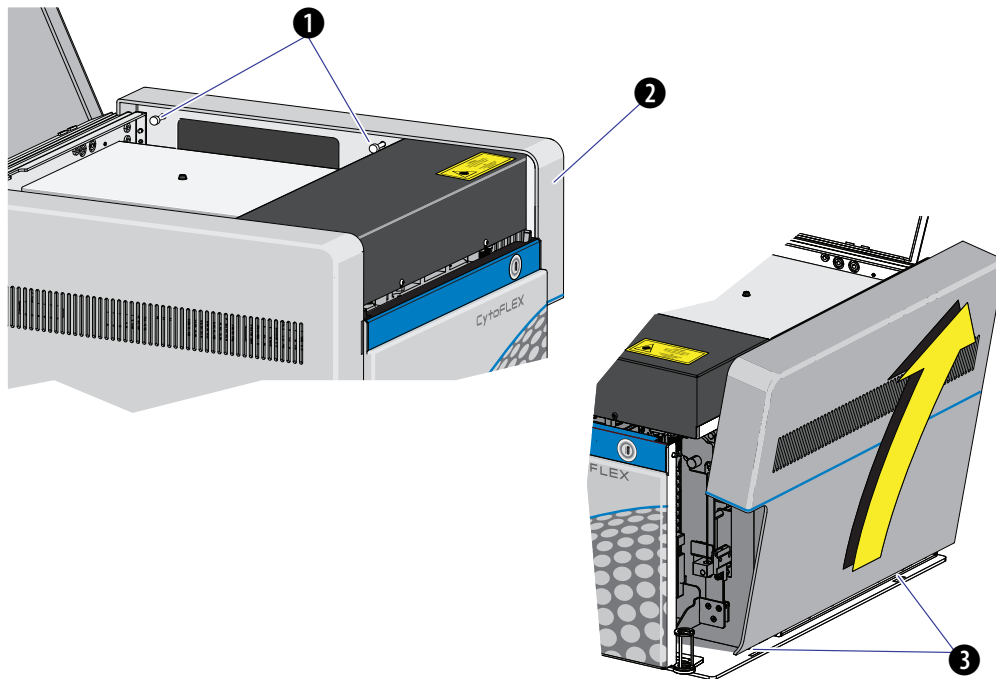

1. Captive thumbscrews
2. Right-side cover
3. Tabs

- 3 Lift the right-side cover up and out of the slots in the frame.

Reinstallation

- 1 Slide the tabs on the bottom of the right-side cover into the slots in the bottom of the frame and push the cover into place.
- 2 Fasten the two captive thumbscrews to secure the right-side cover.

-
- 3 Close the top cover.
-

Filling the Sheath Fluid Container

-
- 1 If necessary, remove any cardboard cutouts from the new CytoFLEX Sheath Fluid cubitainer. If you do not need a new cubitainer, skip to Step 6.
-
- 2 Locate the spigot inside the cardboard cutout.
-
- 3 Remove the cap and seal from the new sheath cubitainer. Be sure to completely remove the foil seal.
-
- 4 Screw on the spigot.
-
- 5 Unscrew the sheath fluid harness from the sheath fluid container and place in the fluid sensor holder cutout (refer to [Figure 1.5.](#)) to prevent contamination of the sheath fluid harness.
-

 **CAUTION**

Risk of instrument damage. Remove the sheath fluid container from the Fluid Container holder and fill away from the instrument to prevent spills that could damage the instrument circuitry.

-
- 6 Remove the sheath fluid container from the Fluid Container holder.
-
- 7 Hold the Sheath fluid container under the CytoFLEX Sheath Fluid cubitainer ensuring the cubitainer is resting on a stable surface.
-
- 8 Fill the sheath fluid container.
-
- 9 Reinstall the sheath fluid harness onto the sheath fluid container.
-
- 10 Place the sheath fluid container back into the Fluid Container holder.
-

Emptying the Waste Container

- 1 Confirm that the instrument is turned off or is in the standby state.
- 2 Remove the waste harness (see [Figure 1.5](#)). The waste harness from the Cytometer is connected to a 4-L waste container.
- 3 Remove the waste container from the Fluid Container holder.

 **WARNING**

Risk of biohazardous contamination if you have skin contact with the waste container, its contents, and its associated tubing. The waste container and its associated tubing might contain residual biological material and must be handled with care. Clean up spills immediately. Dispose of the contents of the waste container in accordance with your local regulations and acceptable laboratory procedures. Use proper personal protective equipment.

- 4 Empty the waste container. Dispose of the waste in accordance with your local regulations and acceptable laboratory procedures.

 **WARNING**



Risk of chemical injury from bleach. To avoid contact with the bleach, use barrier protection, including protective eyewear, gloves, and suitable laboratory attire. Refer to the Safety Data Sheet for details about chemical exposure before using the chemical.



- 5 Add 400 mL of 5 to 6% bleach to the waste container.
- 6 Reinstall the waste harness in the waste container.
- 7 Put the waste container in the Fluid Container holder.

Managing the Maintenance Reminder

The maintenance reminder tracks the last maintenance date and initiates a reminder to complete maintenance for the following three items:

- Refill Deep Clean solution bottle
- Replace sheath fluid filter
- Replace sample peristaltic pump tubing

When reagents or parts have reached the designated use time limit in either days or number of uses, the Maintenance Message icon  Semi-automatic Sampler  Waste  appears in the right side of the status bar.

1 Select the Maintenance Message icon  from the status bar to access the Maintenance window. The expired item appears with a warning triangle  to the left of the item listed.

Or

Select **Maintenance** in the Advanced menu. The Maintenance window appears. The expired item is displayed with a warning triangle  to the left of the item listed.

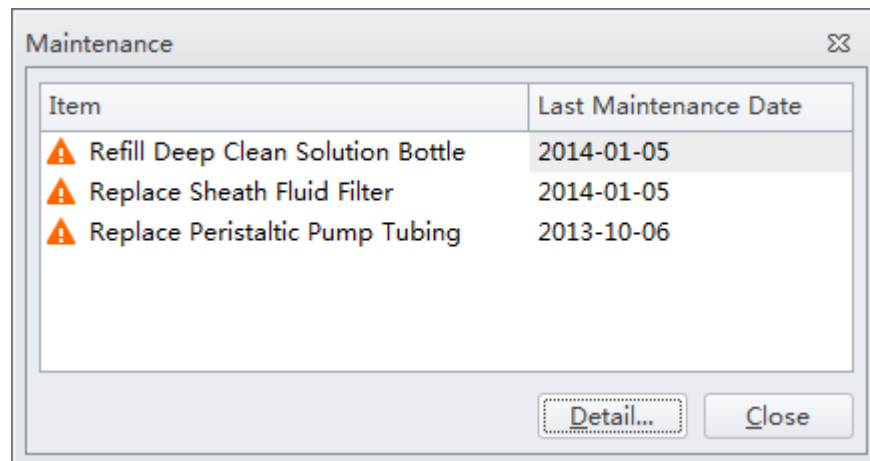

2 Select the desired item to manage, then choose one of the following:

- To manage refilling the Deep Clean solution bottle, go to Step 3.
- To manage replacing the sheath filter, skip to Step 4.
- To manage replacing the sample peristaltic pump tubing, skip to Step 5.

- 3 Select **Detail**. The Refill Deep Clean Solution Bottle window appears.

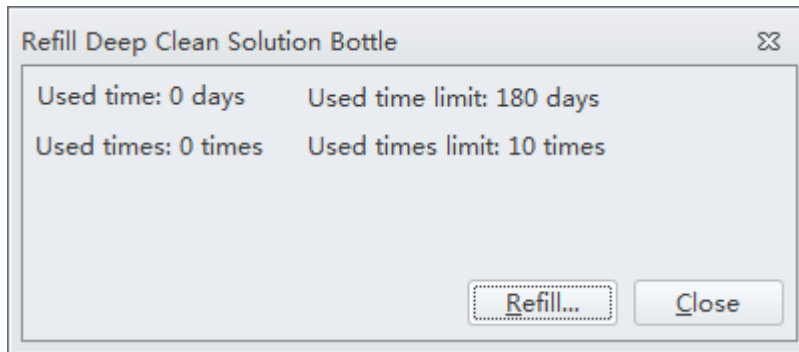

Select **Refill**. A pop-up window appears to reset the maintenance date as the current date that the maintenance was performed.

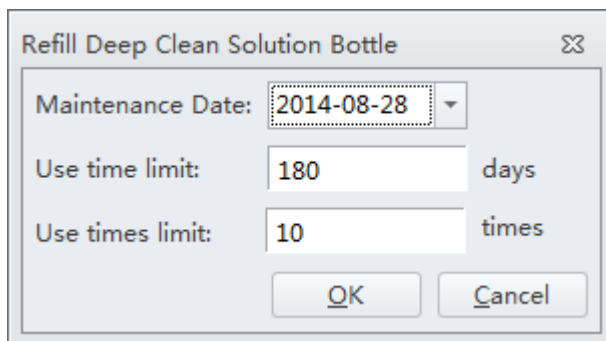

- 4 Select **Detail**. The Replace Sheath Fluid Filter window appears.

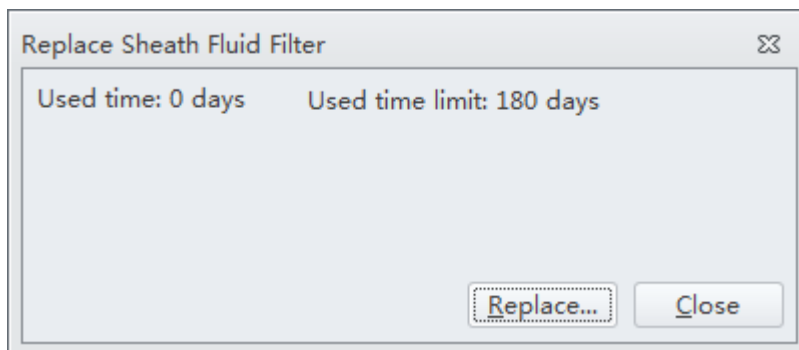

Select **Replace**. A pop-up window appears to reset the maintenance date as the current date that the maintenance was performed.

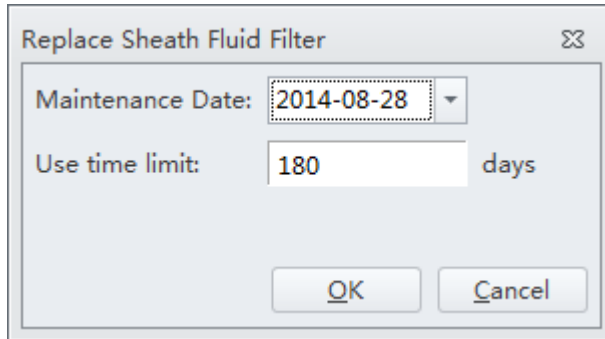

5 Select **Detail**. The Replace Peristaltic Pump Tubing window appears.

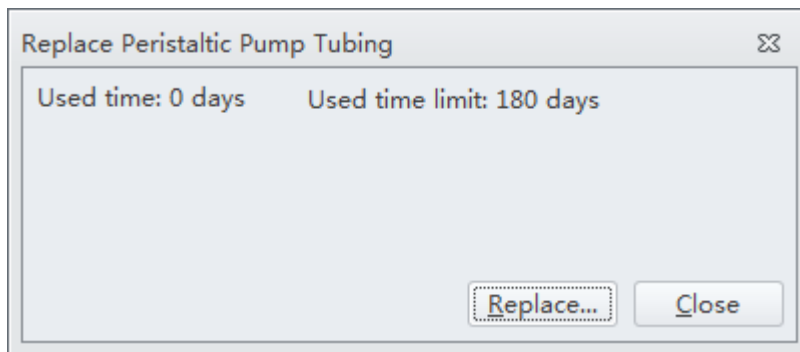

Select **Replace**. A pop-up window appears to reset the maintenance date as the current date that the maintenance was performed.

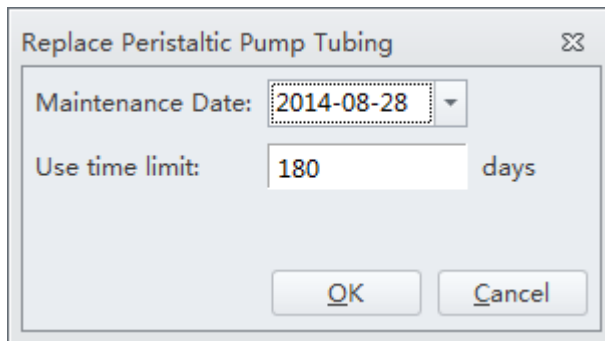

Adding the Deep Clean Solution

Check occasionally whether the Deep Clean solution in the Deep Clean solution bottle is sufficient. Replace the Deep Clean solution when the maintenance reminder prompts you to do so.

⚠ WARNING

Risk of chemical injury from Contrad® 70 reagent. To avoid contact with the Contrad® 70 reagent, use barrier protection, including protective eyewear, gloves, and suitable laboratory attire. Refer to the Safety Data Sheet for details about chemical exposure before using the chemical.

- 1 Make 60 mL of Deep Clean solution by mixing 30 mL of Contrad® 70 and 30 mL DI water in the Deep Clean solution bottle and swirl the solution gently to create the Deep Clean solution.
- 2 Verify that the Cytometer is in standby state or is turned off.
- 3 Remove the right-side cover of the instrument. Refer to [Right-Side Cover Removal and Reinstallation](#).
- 4 Remove the Deep Clean solution bottle and open the cap.

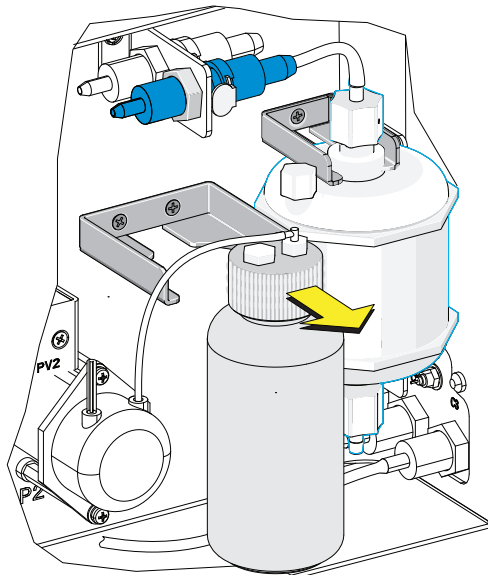

-
- 5** Add 60 mL Deep Clean solution to fill the bottle to the shoulder.

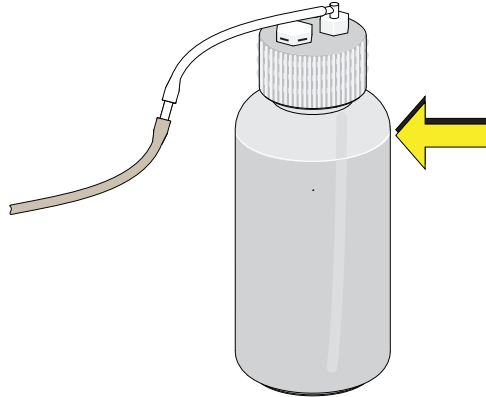

-
- 6** Tighten the cap, and attach the Deep Clean solution bottle to the bracket.

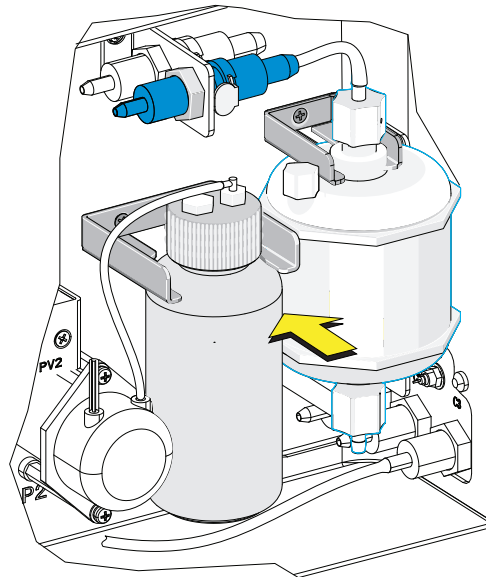

-
- 7** Reinstall the right-side cover (see [Right-Side Cover Removal and Reinstallation](#)), and fasten the thumbscrews.

-
- 8** Reset the maintenance reminder tracker. Refer to [Managing the Maintenance Reminder](#).
-

Replacing the Sheath Fluid Filter

It is recommended to replace the sheath fluid filter every six months when the maintenance reminder prompts you to do so. The life of the filter is related to the quality of the sheath fluid used. If it is found that there are impurities in the light scatter pattern, replace the sheath fluid filter.

- 1 Select **Standby** on the left of the screen to place the instrument in standby state, or shut off the Cytometer's power.
- 2 Remove the right-side cover. Refer to [Right-Side Cover Removal and Reinstallation](#).
- 3 Press the spring piece on the quick connector and the Cytometer on the upper side of the filter, and disconnect the quick connector.

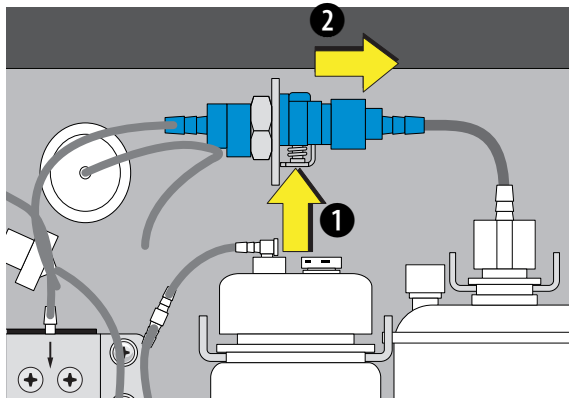

- 4 Repeat Step 3 for the quick connector behind the quick connector removed in the previous step.

NOTE The spring is on the opposite side.

- 5 Remove the sheath fluid filter from the bracket.

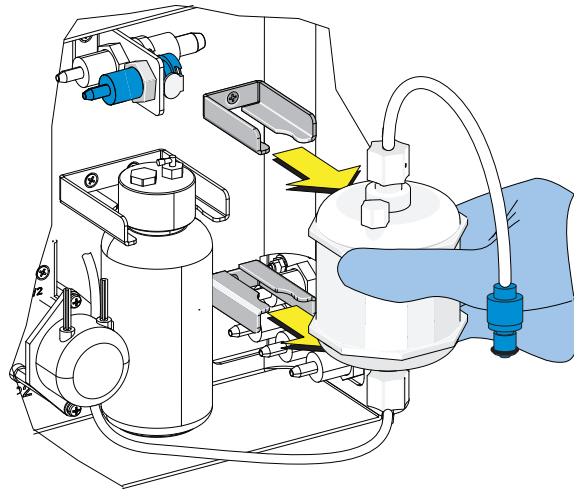

- 6 Connect the new, unused filter using the quick connector springs.

- 7 Attach the filter to the filter bracket.

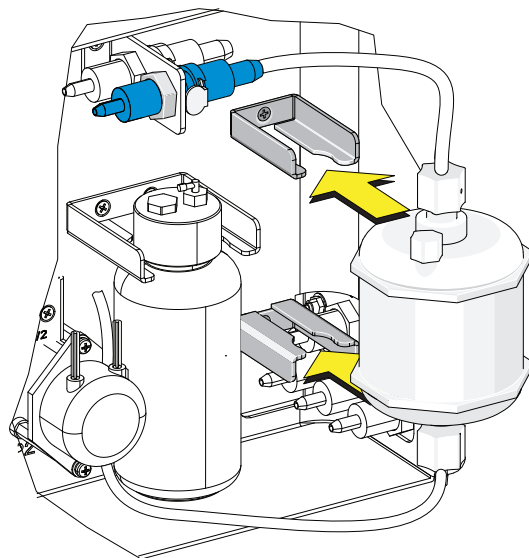

- 8 Remove and set aside the vent cap and the rubber insert.

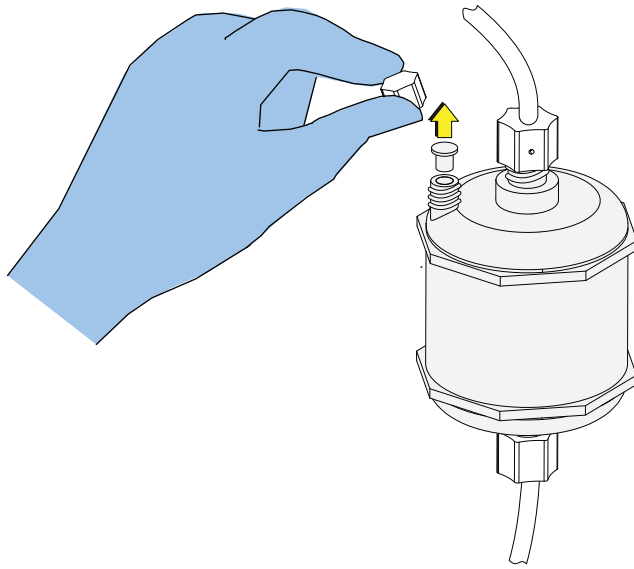

-
- 9 Turn on the Cytometer and open the software.

-
- 10 Select **Prime** in the Cytometer menu.

WARNING

If the vent cap is not sealed tightly, unstable flow rate of the sheath fluid can result, and leakage of the sheath fluid can occur.

- 11 Observe the liquid level in the filter during the prime cycle. When the liquid level reaches the upper section of the filter, reinstall the rubber insert, and lock the vent cap to prevent air leakage.

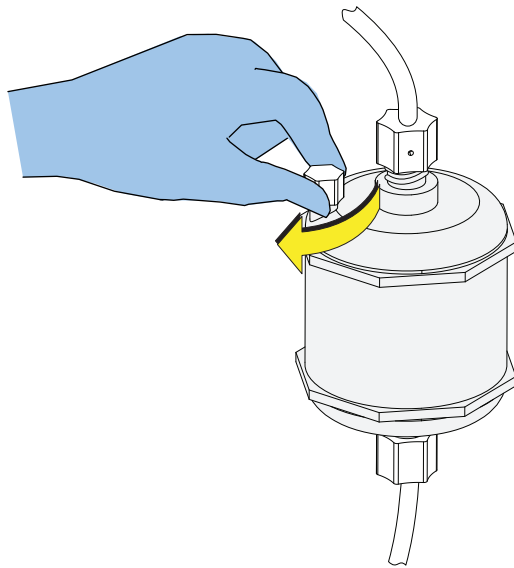

- 12 Reinstall the right-side cover (see [Right-Side Cover Removal and Reinstallation](#)), and lock the screw.
- 13 If the problem persists, contact your Beckman Coulter Representative.
- 14 Run the system startup program. Refer to [Running the System Startup Program](#) in [CHAPTER 3, Daily Startup](#).
- 15 Reset the maintenance reminder tracker. Refer to [Managing the Maintenance Reminder](#).

Replacing the Sample Probe and/or the Sample Peristaltic Pump Tubing

⚠ WARNING

Risk of biohazardous contamination if you have skin contact with the sample probe or the sample peristaltic pump tubing. The sample probe and the sample peristaltic pump tubing could contain residual biological material and must be handled with care. Clean up spills immediately. Dispose of the sample probe and the sample peristaltic pump tubing in accordance with your local regulations and acceptable laboratory procedures.

It is recommended to replace the tubing of the sample peristaltic pump every six months, as tubing used for an excessively long time can cause degradation of the stability of the sample flow and increase of the CV detected.

- 1 Place the instrument in standby state.
- 2 Remove the right-side cover. Refer to [Right-Side Cover Removal and Reinstallation](#).
- 3 Remove the front cover. Refer to [Front Cover Removal and Reinstallation](#).
- 4 Remove the sample pump cover thumbscrew and the sample pump cover.

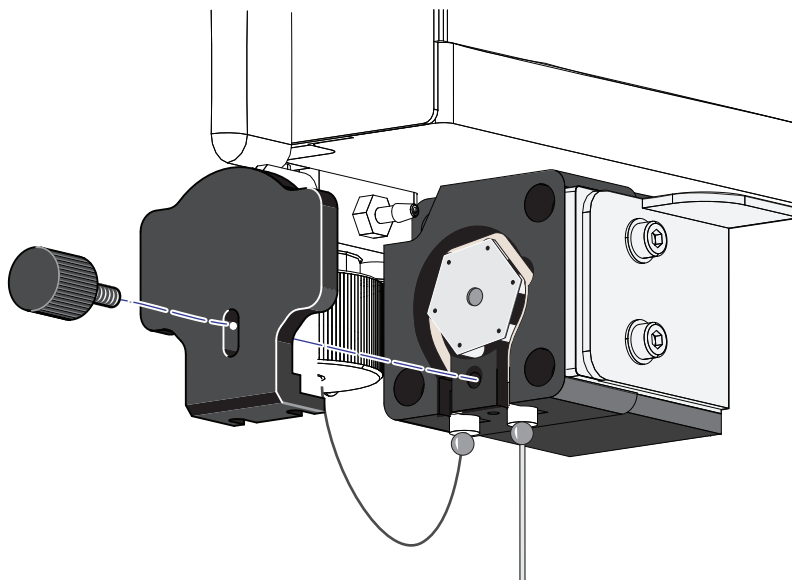

- 5 Take out the sample peristaltic pump tubing.

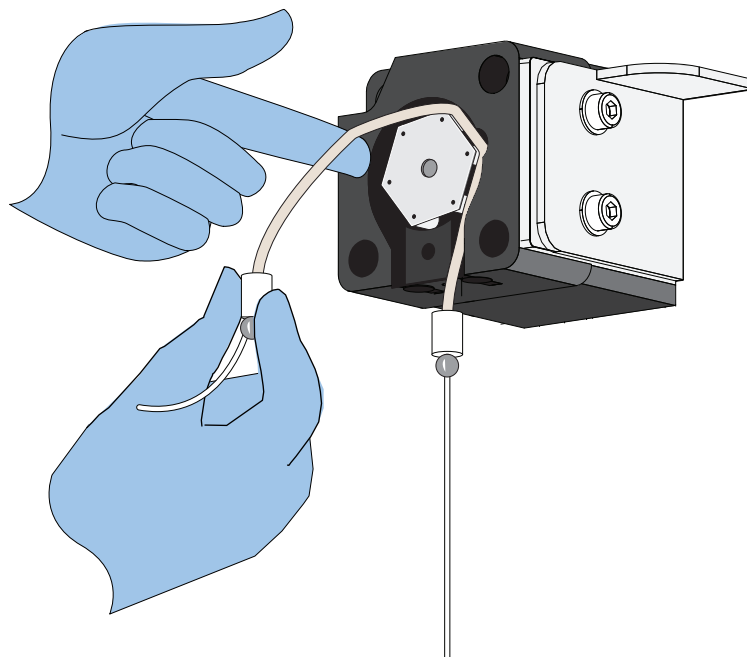

- 6 Remove the sample PEEK tubing from the sample peristaltic pump tubing.

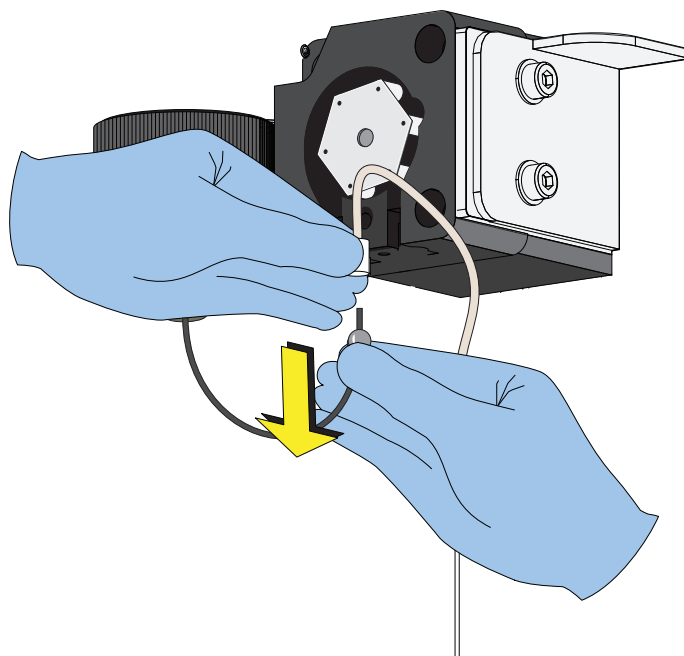

-
- 7** Lift the sample probe out of the wash station.

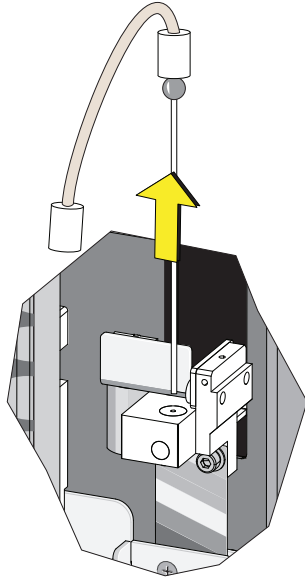

-
- 8** Remove the sample peristaltic pump tubing from the sample probe.

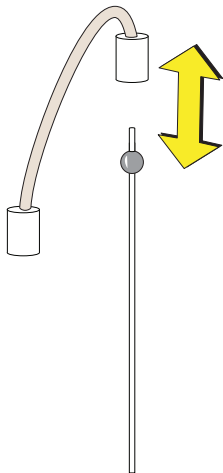

-
- 9** Dispose of the old sample probe and/or sample peristaltic pump tubing in accordance with your local regulations and acceptable laboratory procedures.

10 Connect the sample peristaltic pump tubing to the sample probe.

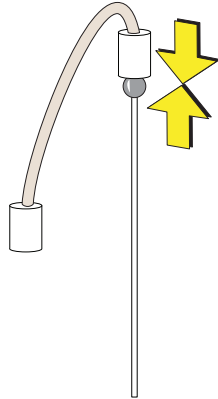

11 Connect the sample PEEK tubing to the sample peristaltic pump tubing.

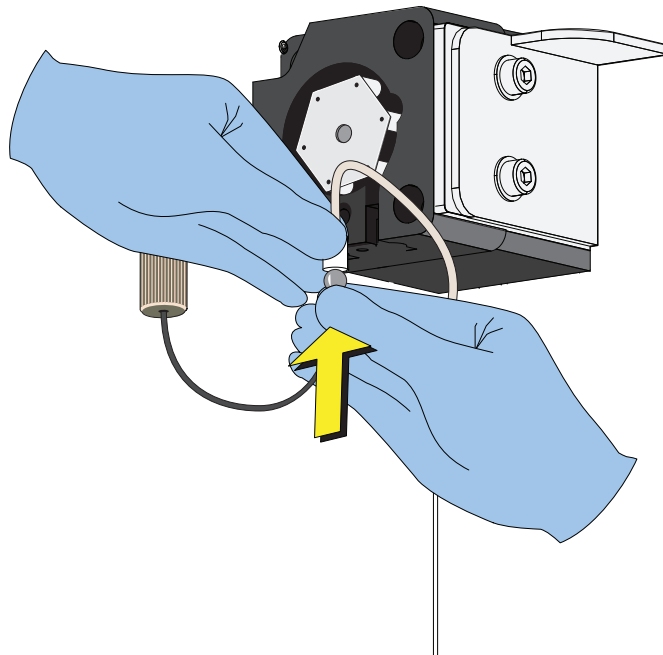

12 Slide the sample probe into the wash station.

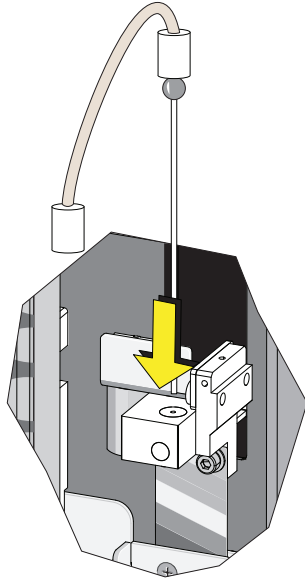

13 Install the sample peristaltic pump tubing, taking care not to use any sharp tools, ensuring that the tube is fully inserted into the groove.

NOTE You can use the sample pump cover thumbscrew to install the sample peristaltic pump tubing.

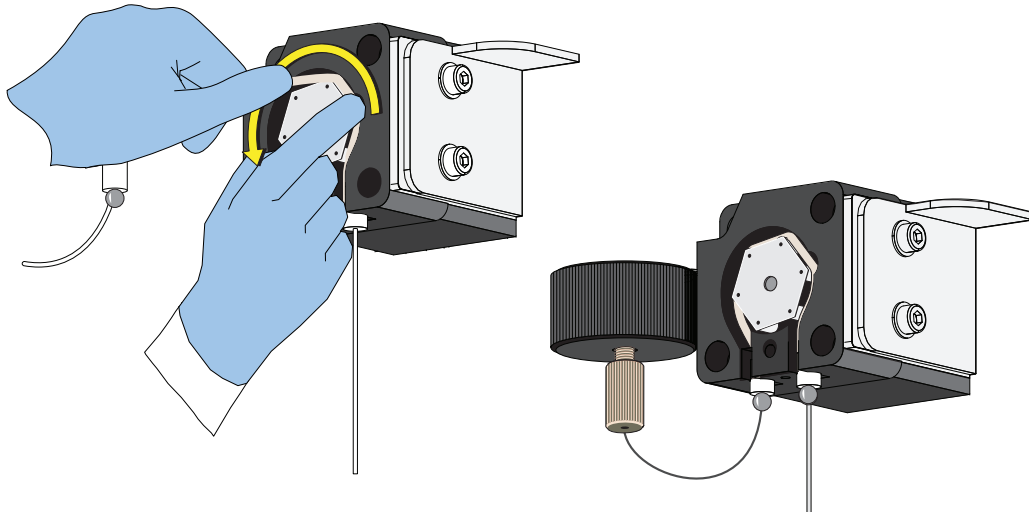

- 14 Install the sample pump cover.

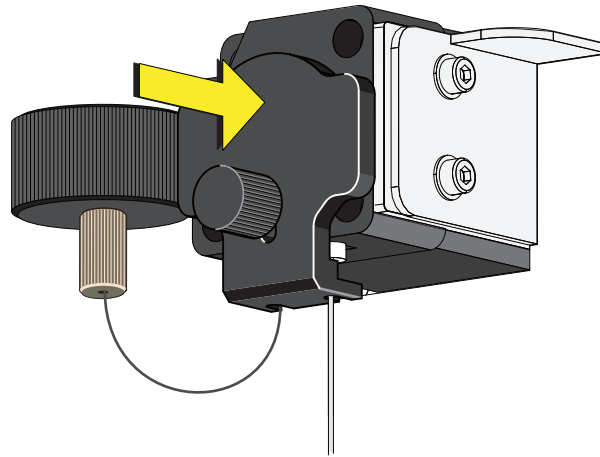

NOTE To ensure the proper placement of the sample probe, push the sample pump cover up while installing the thumbscrew.

- 15 Reinstall the right-side cover (see [Right-Side Cover Removal and Reinstallation](#)), and lock with the screw.

Replacing the Sample Probe Assembly [With Plate Loader]

WARNING

Risk of biohazardous contamination if you have skin contact with the sample probe or the sample peristaltic pump tubing. The sample probe and the sample peristaltic pump tubing could contain residual biological material and must be handled with care. Clean up spills immediately. Dispose of the sample probe and the sample peristaltic pump tubing in accordance with your local regulations and acceptable laboratory procedures.

- 1 Turn the Cytometer's main power switch off.
- 2 Remove the right-side cover. Refer to [Right-Side Cover Removal and Reinstallation](#) in CHAPTER 11, [Replacement/Adjustment Procedures](#).
- 3 Remove the front cover. Refer to [Front Cover Removal and Reinstallation](#) in CHAPTER 11, [Replacement/Adjustment Procedures](#).

-
- 4 Remove the sample pump cover thumbscrew and the sample pump cover.

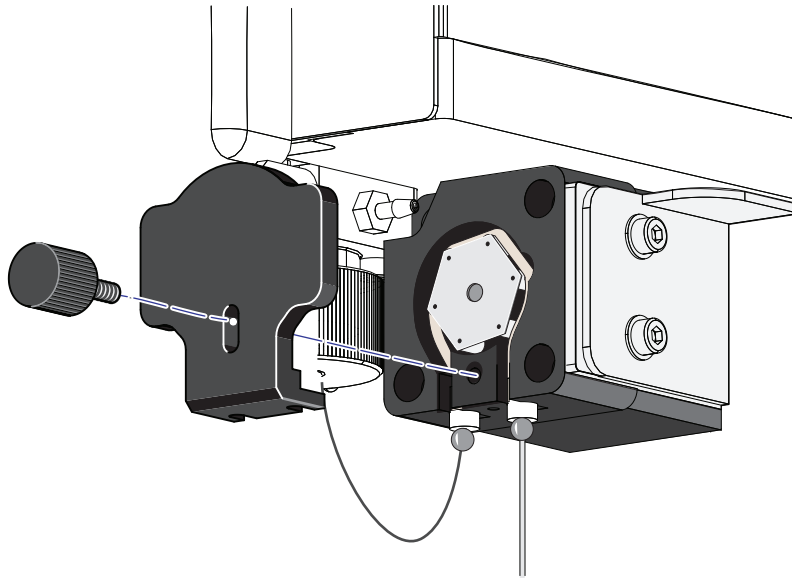

-
- 5 Remove the plate loader PEEK tubing from the sample peristaltic pump tubing.

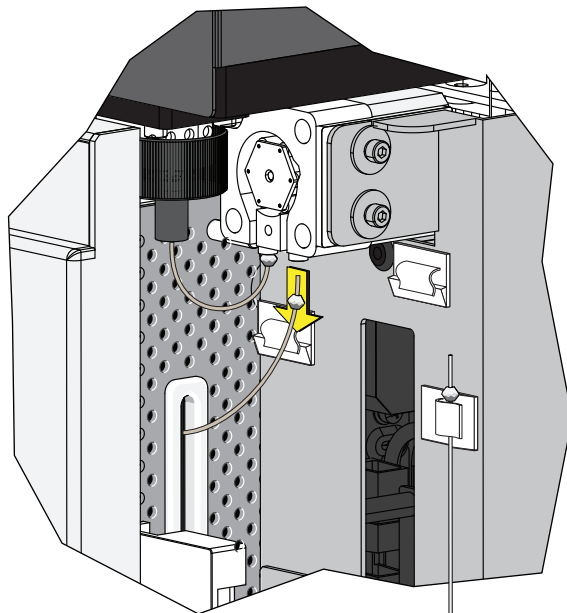

⚠ CAUTION

The plate loader PEEK tubing can be deformed which could affect sample flow. When routing the plate loader PEEK tubing to and from the Sample Station, be careful not to pinch, crimp, stretch, or break the tubing.

- 6 Pull the plate loader PEEK tubing through the slot so the tubing sits inside the instrument.

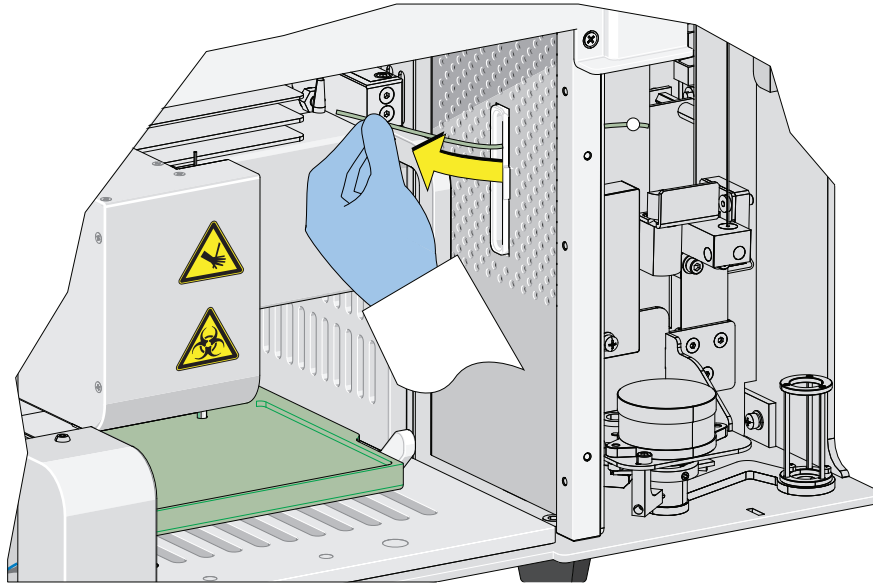

- 7 Loosen the white plastic thumbscrew behind the plate loader sample probe.

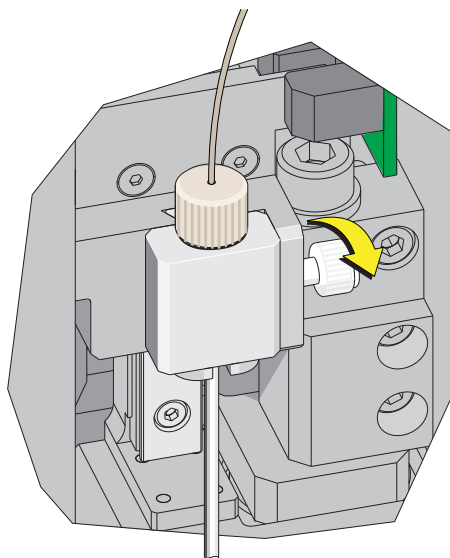

- 8 Lift the plate loader sample probe assembly straight up to remove it from the probe holder.

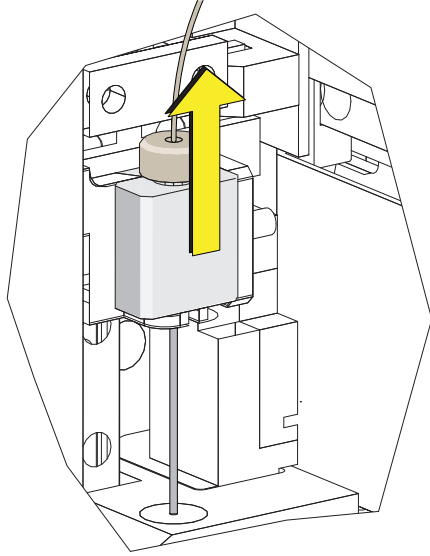

- 9 Align the tongue on the plate loader sample probe assembly with the groove in the probe holder and slide the probe down until it is flush with the probe holder.

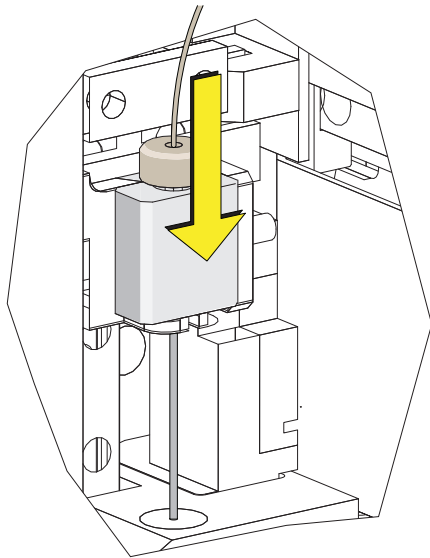

- 10 Tighten the white plastic thumbscrew.

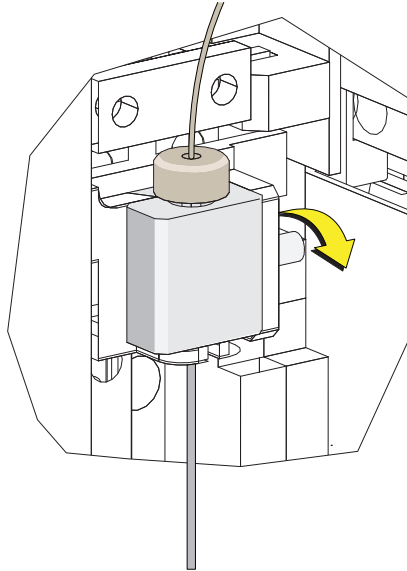

CAUTION

The plate loader PEEK tubing can be deformed which could affect sample flow. When routing the plate loader PEEK tubing to and from the Sample Station, be careful not to pinch, crimp, stretch, or break the tubing.

- 11 Slide the new plate loader PEEK tubing through the slot into the single tube sample station area.

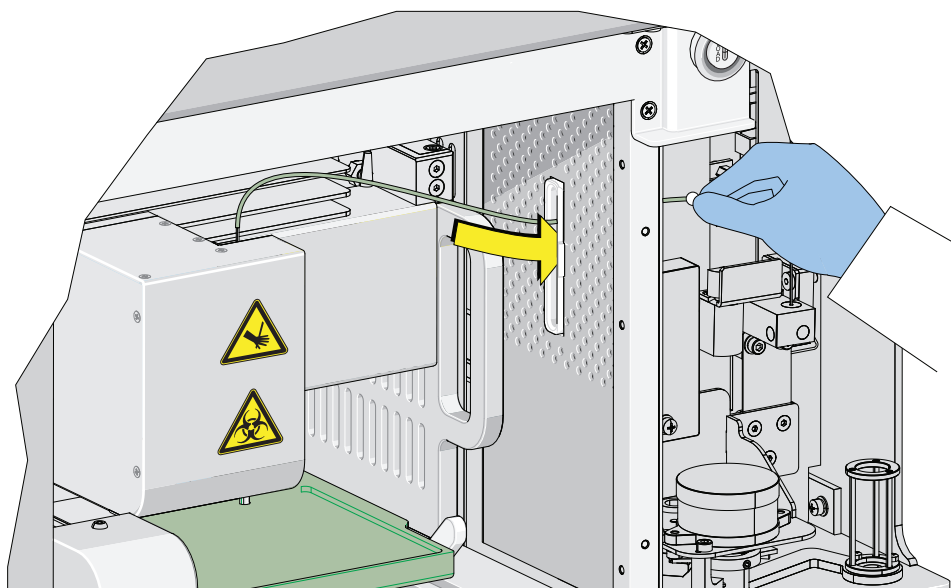

-
- 12 Connect the sample peristaltic pump tubing to the plate loader PEEK tubing.

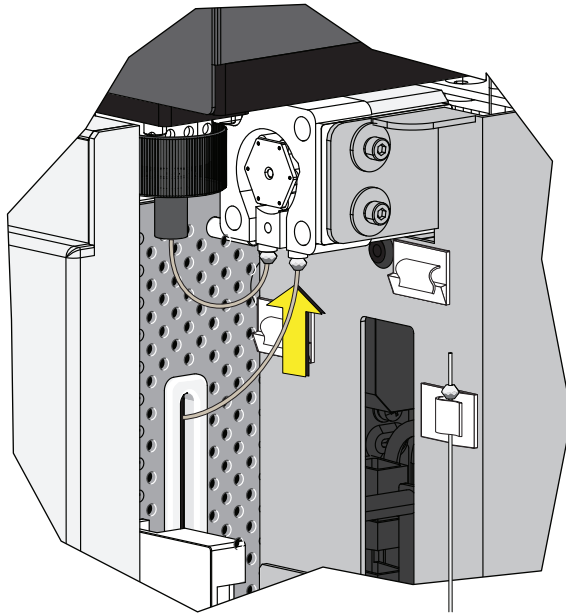

-
- 13 Install the sample pump cover.

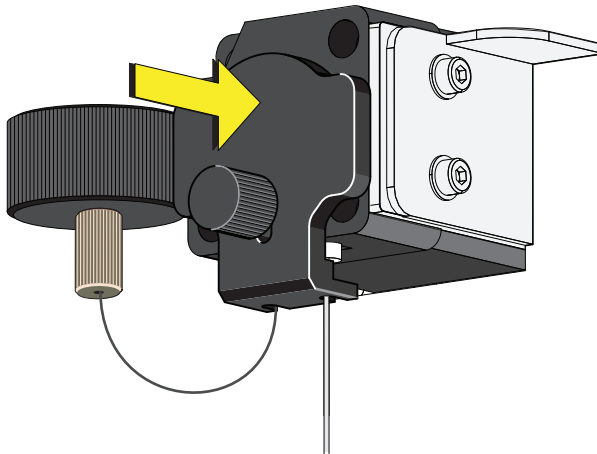

NOTE To ensure the proper placement of the sample probe, push the sample pump cover up while installing the thumbscrew.

-
- 14 Reinstall the right-side cover (refer to [Right-Side Cover Removal and Reinstallation](#) in [CHAPTER 11, Replacement/Adjustment Procedures](#)), and lock with the screw.

-
- 15 Close the top cover.

-
- 16 Turn the Cytometer's main power switch on.
-

Changing the Sample Probe from the Single Tube Sample Station to the Plate Loader [With Plate Loader]

 **WARNING**

Risk of biohazardous contamination if you have skin contact with the sample probe or the sample peristaltic pump tubing. The sample probe and the sample peristaltic pump tubing could contain residual biological material and must be handled with care. Clean up spills immediately.

-
- 1 Switch to the Plate Loader sample injection mode. Refer to [Selecting the Plate Loader Sample Injection Mode \[With Plate Loader\]](#) in CHAPTER 3, Daily Startup.

 - 2 Lift the top cover.

 - 3 Remove the right-side cover. Refer to [Right-Side Cover Removal and Reinstallation](#) in CHAPTER 11, Replacement/Adjustment Procedures.

 - 4 Remove the front cover. Refer to [Front Cover Removal and Reinstallation](#) in CHAPTER 11, Replacement/Adjustment Procedures.

-
- 5 Remove the sample pump cover thumbscrew and the sample pump cover.

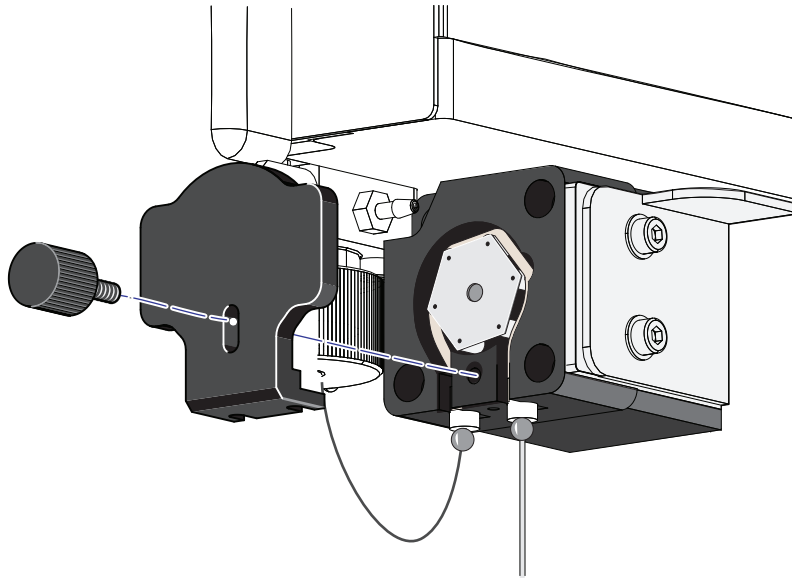

-
- 6 Remove the sample probe from the single tube sample station.

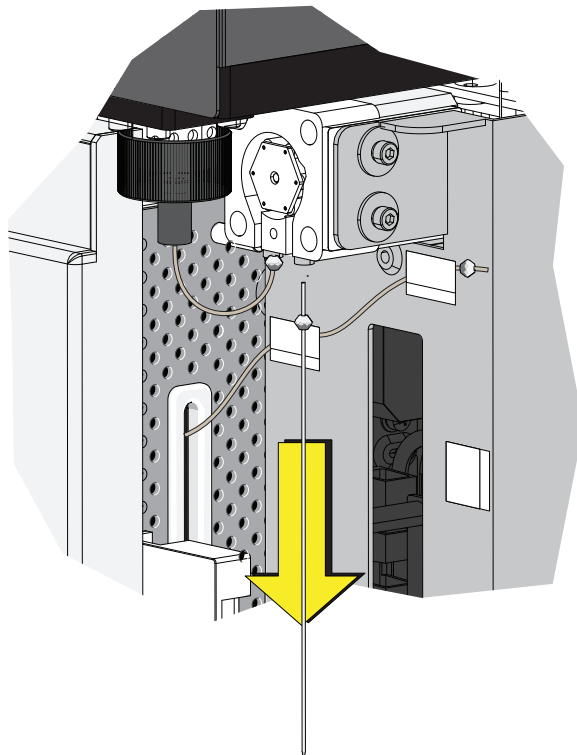

- 7 Place the sample probe in the white clip located on the right side of the sample station.

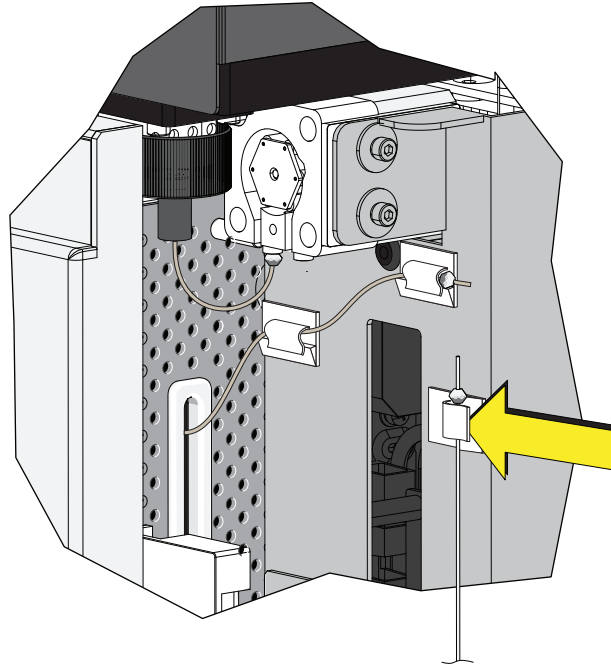

CAUTION

The plate loader PEEK tubing can be deformed which could affect sample flow. When removing the plate loader PEEK tubing from the white clips, be careful not to pinch, crimp, stretch, or break the tubing.

- 8 Remove the plate loader PEEK tubing from the two white clips located at the top of the sample station.

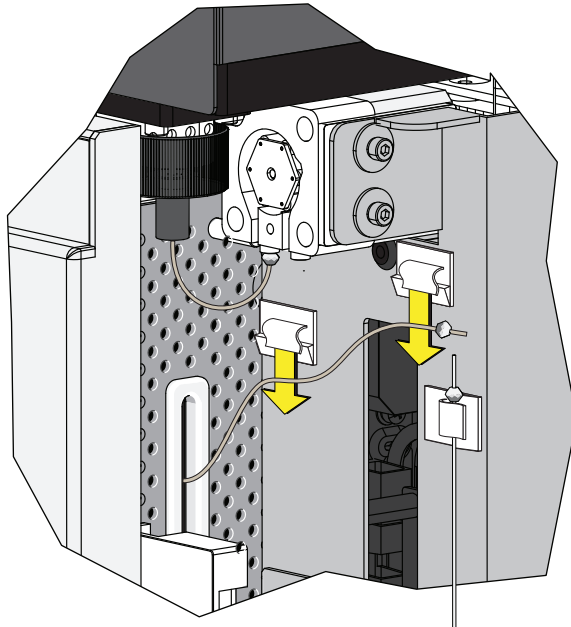

-
- 9 Connect the plate loader PEEK tubing to the sample peristaltic pump tubing.

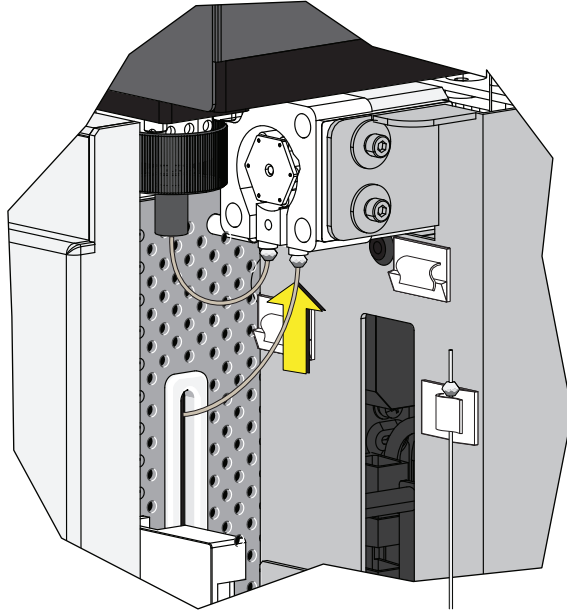

-
- 10 Reinstall the sample pump cover.

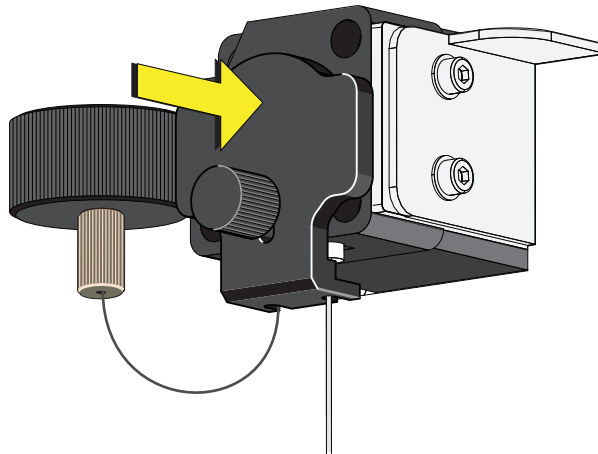

NOTE To ensure the proper placement of the sample probe, push the sample pump cover up while installing the thumbscrew.

-
- 11 Reinstall the right-side cover (refer to [Right-Side Cover Removal and Reinstallation](#) in [CHAPTER 11, Replacement/Adjustment Procedures](#)), and lock with the screw.

-
- 12 Close the top cover.

-
- 13** Turn the Cytometer's main power switch on.
-

Changing the Sample Probe from the Plate Loader to the Single Tube Sample Station [With Plate Loader]

 **WARNING**

Risk of biohazardous contamination if you have skin contact with the sample probe or the sample peristaltic pump tubing. The sample probe and the sample peristaltic pump tubing could contain residual biological material and must be handled with care. Clean up spills immediately.

-
- 1** Switch to either the Semi-Automatic or manual sample injection mode. Refer to [Selecting the Proper Sample Injection Mode](#) in [CHAPTER 3, Daily Startup](#).
-
- 2** Lift the top cover.
-
- 3** Remove the right-side cover. Refer to [Right-Side Cover Removal and Reinstallation](#) in [CHAPTER 11, Replacement/Adjustment Procedures](#).
-
- 4** Remove the front cover. Refer to [Front Cover Removal and Reinstallation](#) in [CHAPTER 11, Replacement/Adjustment Procedures](#).

-
- 5** Remove the sample pump cover thumbscrew and the sample pump cover.

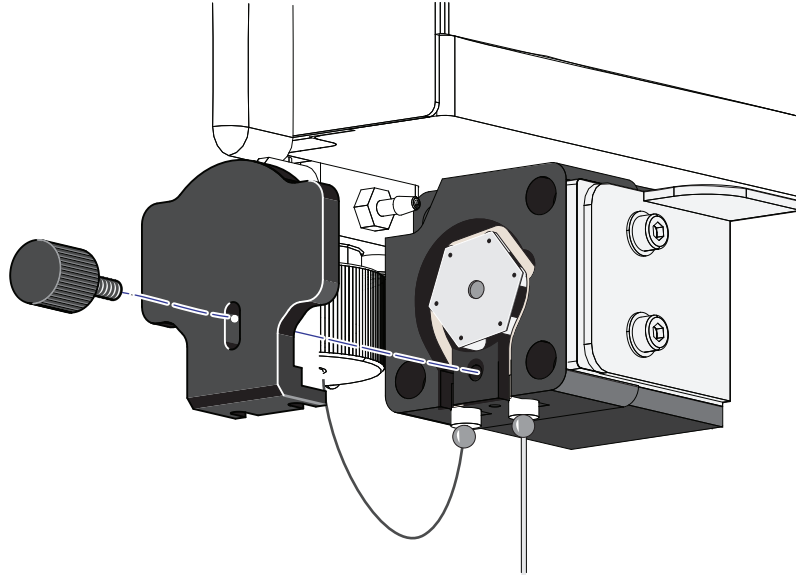

-
- 6** Remove the plate loader PEEK tubing from the sample peristaltic pump tubing.

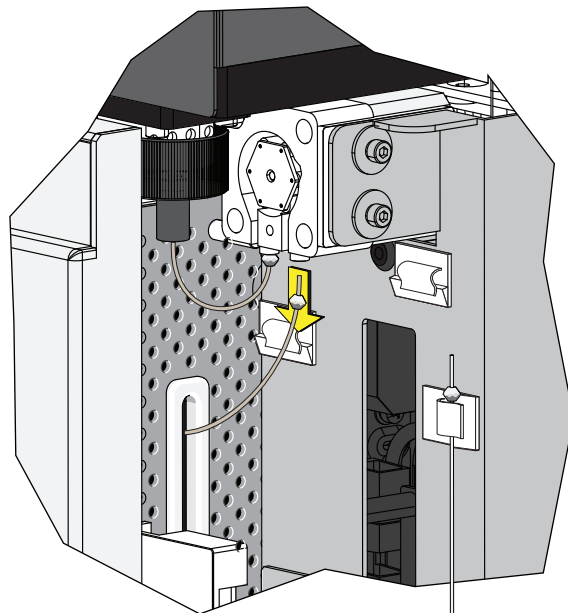

CAUTION

The plate loader PEEK tubing can be deformed which could affect sample flow. When placing the plate loader PEEK tubing in the white clips, be careful not to pinch, crimp, stretch, or break the tubing.

- 7 Place the plate loader PEEK tubing in the two white clips located at the top of the sample station.

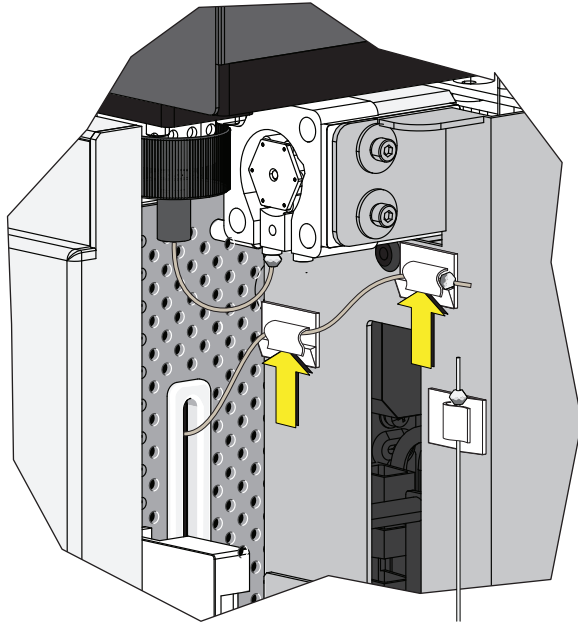

- 8 Remove the sample probe from the white clip located on the right side of the sample station.

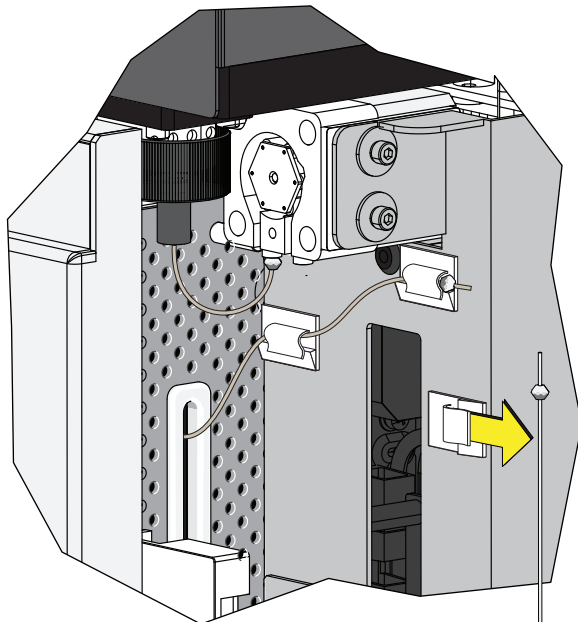

- 9 Connect the sample probe to the sample peristaltic pump tubing.

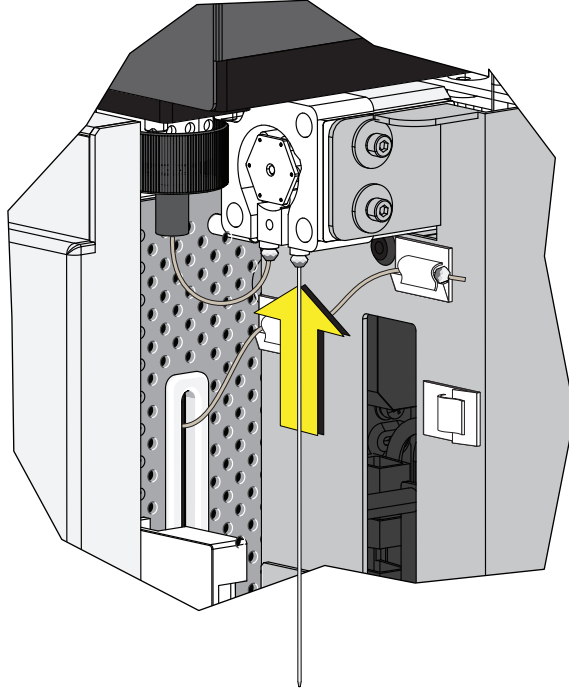

- 10 Run [Daily Clean](#) in [CHAPTER 10, Cleaning Procedures](#).

Inspecting the Liquid Flow Path for Leaks

⚠ WARNING

The liquid flow tubing can aged and cracked or the connector can be loosened. Liquid leakage can lead to biological harm. To reduce occurrence of such problems, carry out liquid flow tubing inspection every six months and ensure that the Fluidics module functions without any leaks. If any leaks are found when using the Cytometer, stop the experiment immediately and look for the source of the leak.

- 1 Remove the right-side cover of the instrument. Refer to [Right-Side Cover Removal and Reinstallation](#).
- 2 Perform instrument initialization to enable the sheath fluid to flow. Refer to [Initializing the Instrument](#) in [CHAPTER 3, Daily Startup](#).

-
- 3 Check the connectors and tubes in the Fluidics module, and check whether any liquid leaks out.

 - 4 Check the sheath fluid, backflush, and waste liquid connector on the back of the Cytometer, and check whether any liquid leaks out.

 - 5 Place the instrument in standby state, complete the priming procedure, and check whether the Fluidics module has any liquid leakage.

 - 6 If any liquid leaks out and the point of liquid leakage is from the filter, try to tighten the filter connector and check again. If the problem persists, replace the sheath fluid filter.

 - 7 If any liquid leaks out from any other connector or tube, stop running the instrument and contact your Beckman Coulter Representative.
-

Priming the Flow Cell

Priming of the flow cell is required when:

- The instrument is not used for a long period of time.
- The sheath fluid is refilled.
- The instrument is being used for the first time.
- The signal of the instrument is poor or the signal drifts.
- The sheath filter is replaced.

-
- 1 Ensure that the instrument is in standby state.

NOTE If the instrument is not already in the standby state, select **Standby** from the Cytometer Menu or select **Standby** in the Data Acquisition Control screen.

- 2 Select **Prime** from the Cytometer Menu to prime the flow cell. Wait for the beep and for the Instructions window to close.

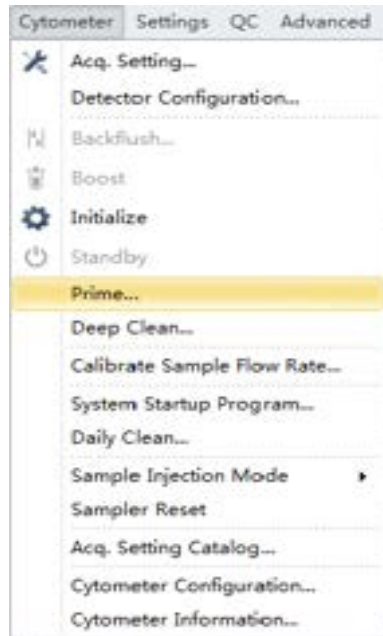

Otherwise, look for the status bar to display that priming has completed.

 [6/24/2013 1:33:45 PM] Completed Priming.

- 3 Run Daily Clean to clean the sample line. Refer to [Daily Clean](#) in [CHAPTER 10, Cleaning Procedures](#)

Replacing the Plate Holder [With Plate Loader]

Figure 11.1 Plate Holder Stage

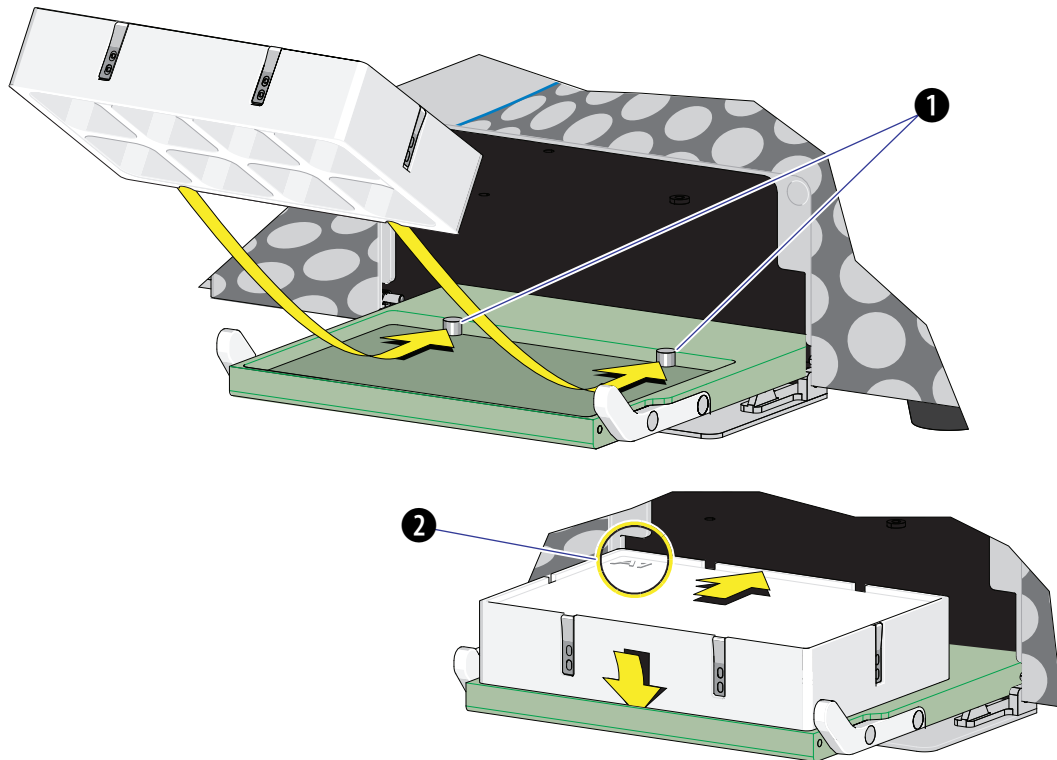

1. Pins
2. Position A1

CAUTION

The plate holder must be secured tightly to the plate holder stage with position A1 located in the top, left corner of the plate holder stage (refer to [Figure 11.1](#)) to prevent instrument damage.

Slide the notches on the bottom of the plate holder (refer to [Figure 1.12](#)) over the pins (refer to [Figure 11.1](#)).

Plate Loader Module Removal and Reinstallation [With Plate Loader]



Risk of contamination from biohazardous material. Always wear PPE when performing this procedure as you can contact components with blood residue.

Removal

- 1 Power down the instrument and disconnect the power cable from the wall.
 - 2 Lift the top cover and remove the front cover. Refer to [Front Cover Removal and Reinstallation](#).
 - 3 Place absorbent material on the stage in the Plate Loader module.
-

- 4 In the Sample Station, disconnect that end of the plate loader PEEK tubing.
- If the plate loader PEEK tubing is attached to the sample peristaltic pump tubing, remove the sample pump cover and disconnect the plate loader PEEK tubing.

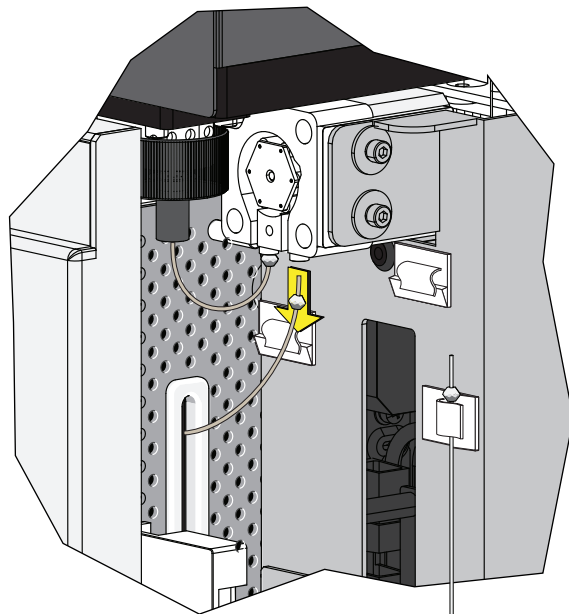
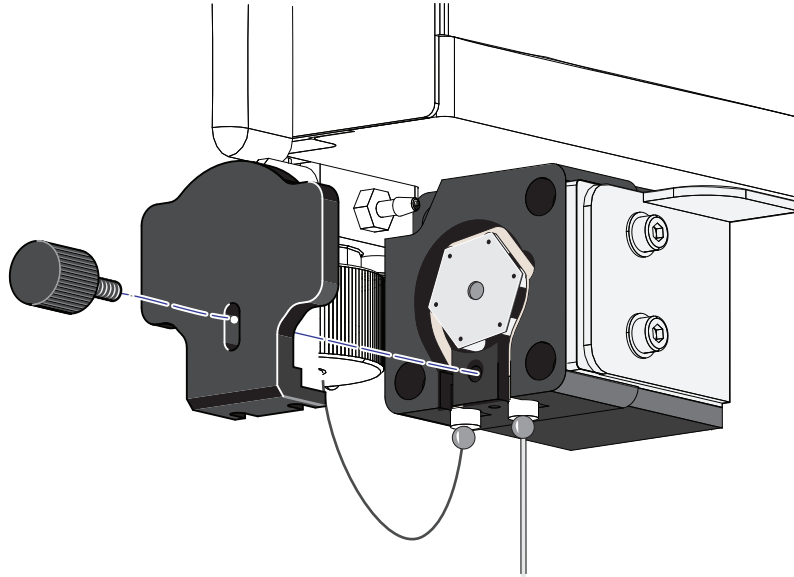

- If the plate loader PEEK tubing is in the plate loader PEEK tubing clips, remove the tubing from the clips.

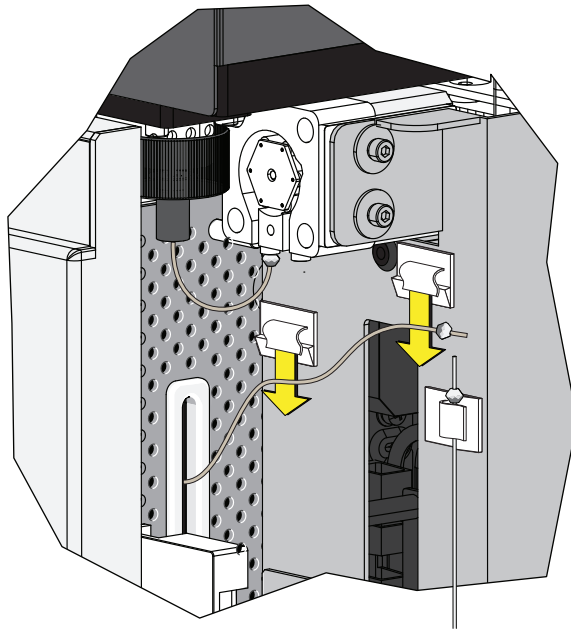

CAUTION

The PEEK tubing can be deformed which could affect sample flow. When routing the Plate Loader PEEK tubing to and from the Sampling Station, be careful not to pinch, crimp, stretch, or break the tubing.

- 5 Pull the plate loader PEEK tubing through the slot so the tubing sits inside the instrument.

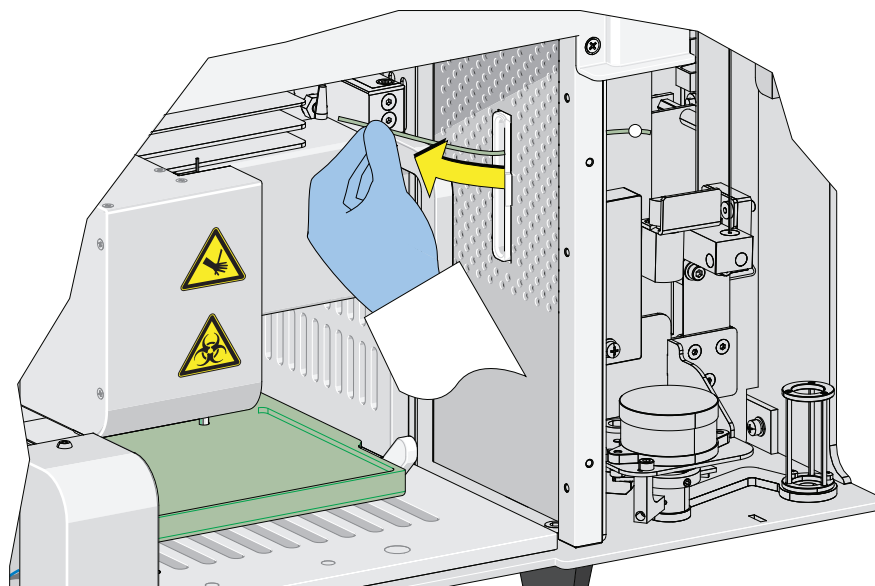

- 6 Remove the red and black marked tubings that are attached to the left and right connectors in the Plate Loader module, respectively, as shown in [Figure 11.2](#).

Figure 11.2 Removing the Tubings from the Fluidics Module to the Plate Loader

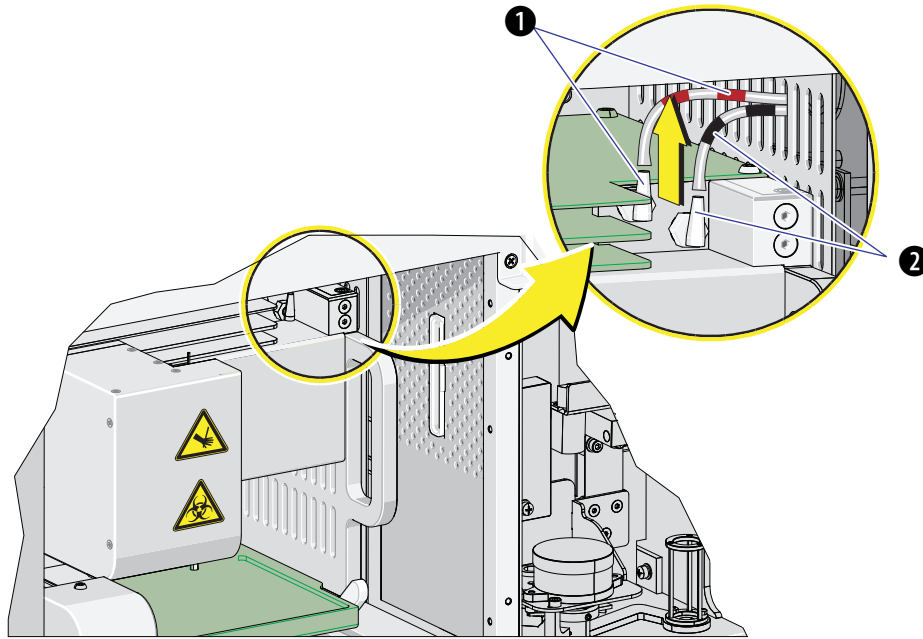

1. Red
2. Black

- 7 Remove the two countersunk M4 x 10 Phillips-head screws in the Plate Loader module. Refer to [Figure 11.3](#).

Figure 11.3 Plate Loader Module Securing Screws

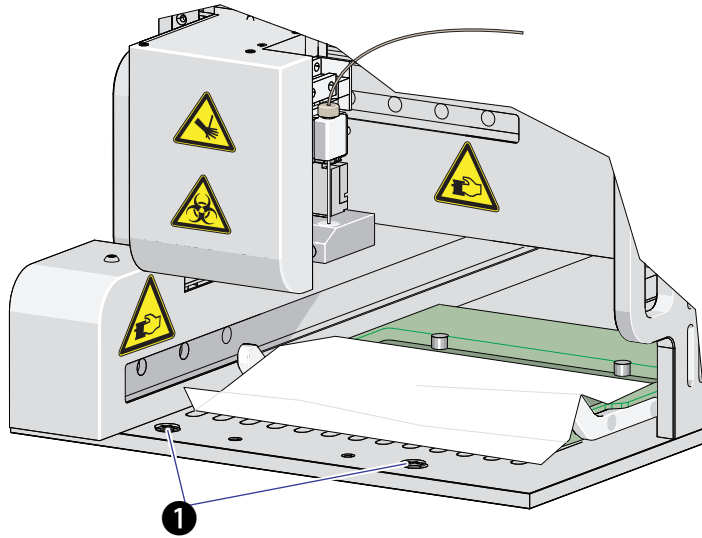

1. Securing screws

- 8 Slide the Plate Loader module out of the Cytometer. Refer to [Figure 11.4](#).

Figure 11.4 Removing the Plate Loader from the Cytometer

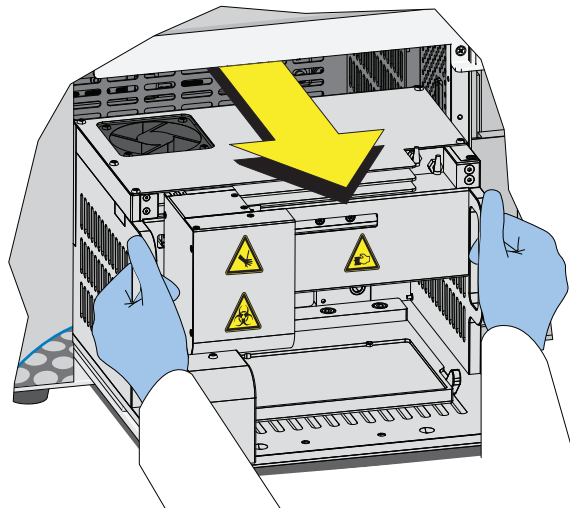

Installation

- 1 Remove the front cover. Refer to [Front Cover Removal and Reinstallation](#).

- 2 Remove the right-side cover. Refer to [Right-Side Cover Removal and Reinstallation](#).

- 3 Slide the Plate Loader module in to the Cytometer. Refer to [Figure 11.5](#).

Figure 11.5 Installing the Plate Loader in to the Cytometer

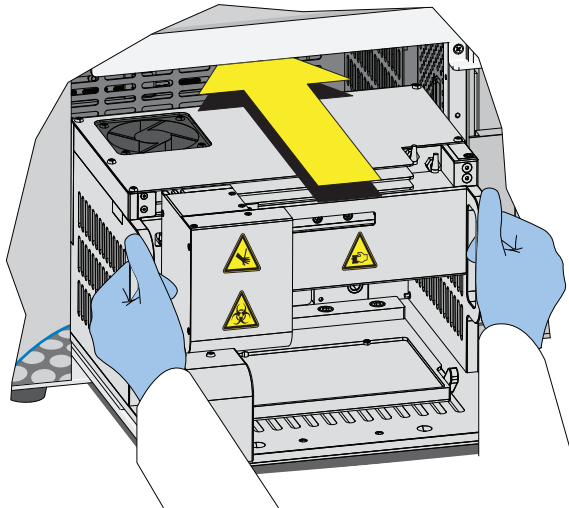

- 4 Install the two countersunk M4 x 10 Phillips-head screws in the Plate Loader module. Refer to [Figure 11.6](#).

Figure 11.6 Plate Loader Module Securing Screws

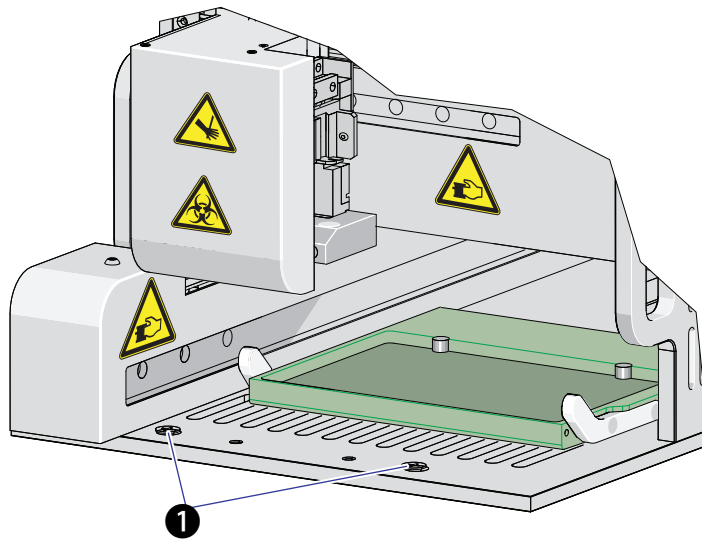

1. Securing screws

- 5 Install the red and black marked tubings that are attached to the left and right connectors in the Plate Loader module, respectively, as shown in [Figure 11.7](#).

Figure 11.7 Connecting the Tubings from the Fluidics Module to the Plate Loader

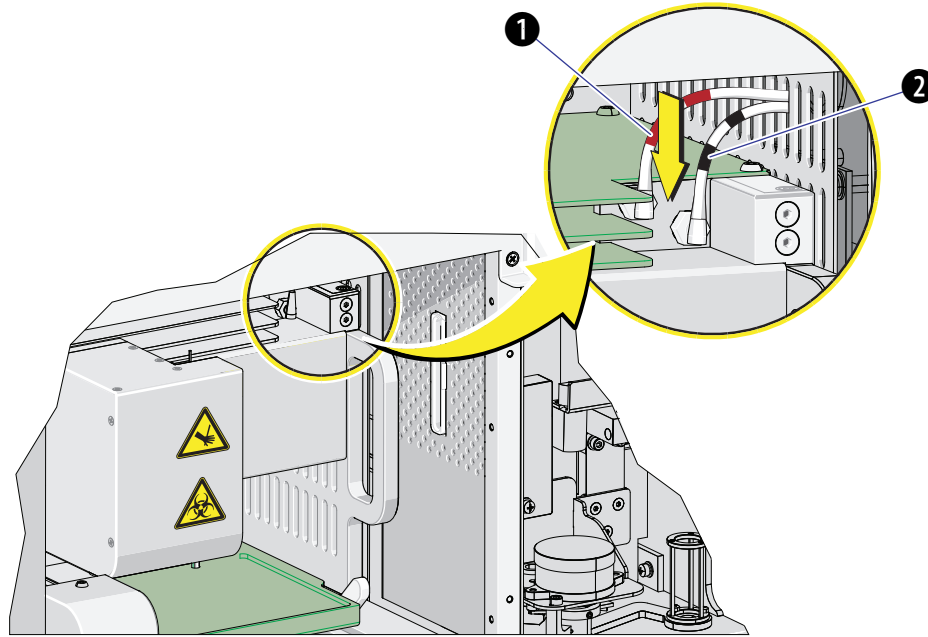

1. Red
2. Black

CAUTION

The PEEK tubing can be deformed which could affect sample flow. When routing the Plate Loader PEEK tubing to and from the Sampling Station, be careful not to pinch, crimp, stretch, or break the tubing.

- 6 Slide the new plate loader PEEK tubing through the slot into the single tube sample station area.

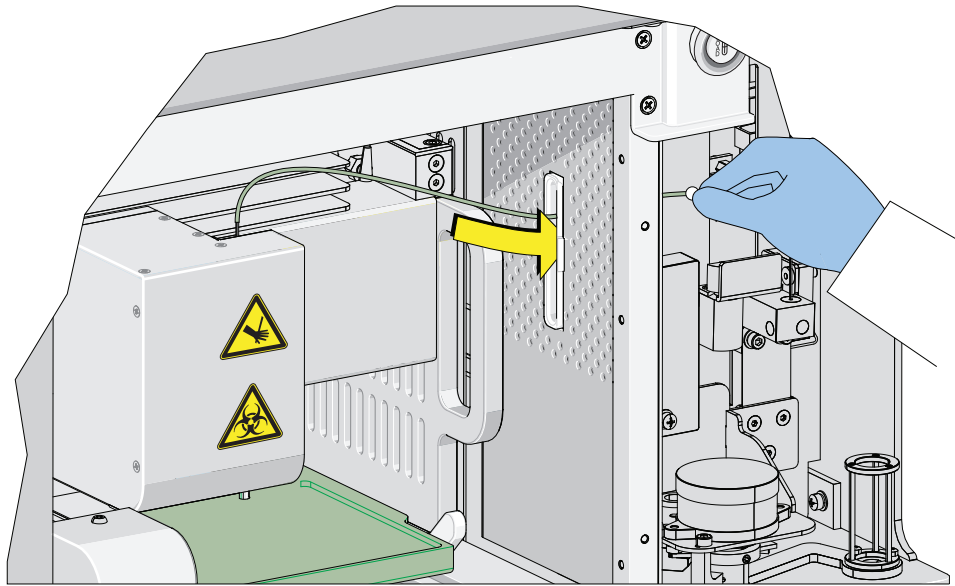

- 7 Remove the sample pump cover thumbscrew and the sample pump cover.

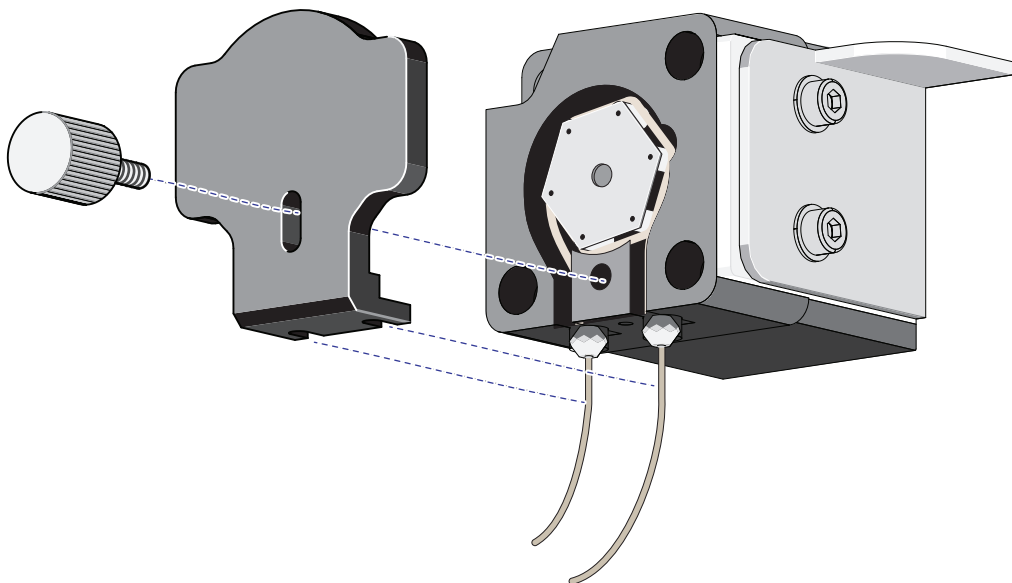

- 8 Connect the plate loader PEEK tubing to the sample peristaltic pump tubing.

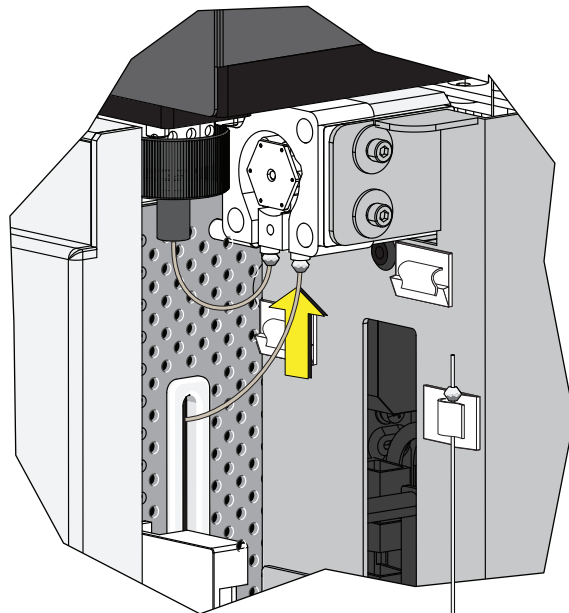

- 9 Reinstall the sample pump cover.

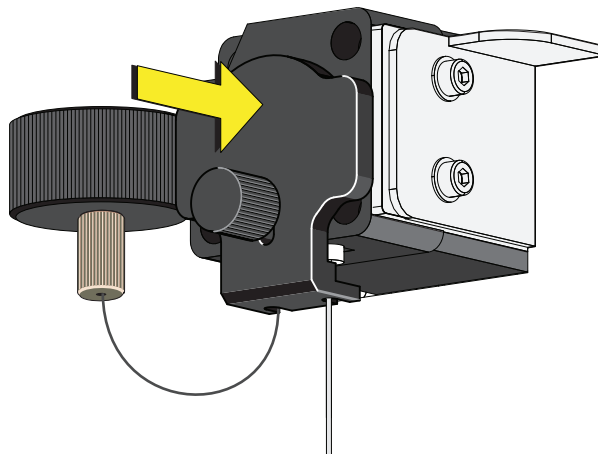

NOTE To ensure the proper placement of the sample probe, push the sample pump cover up while installing the thumbscrew.

- 10 Replace the right-side cover (refer to [Right-Side Cover Removal and Reinstallation](#) in [CHAPTER 11, Replacement/Adjustment Procedures](#)), and lock with the screw.

- 11 Replace the front cover. Refer to [Front Cover Removal and Reinstallation](#).

- 12 Close the top cover.
- 13 Turn the Cytometer's main power switch on.
- 14 Verify that the system is operating correctly by running QC in the Plate Loader mode. Refer to [Preparing the QC Sample \[With Plate Loader\]](#) and [Collecting QC Data \[With Plate Loader\]](#) in CHAPTER 4, Instrument Quality Control.

Changing the Event Rate Setting

The Event Rate Setting adjusts the collection setting around signal measurement so that the system is able to optimize the acquisition of events ensuring optimal sensitivity and abort rates when acquiring at higher event rates.

- 1 Select **Event Rate Setting** in the Advanced menu. The Event Rate Setting window appears.

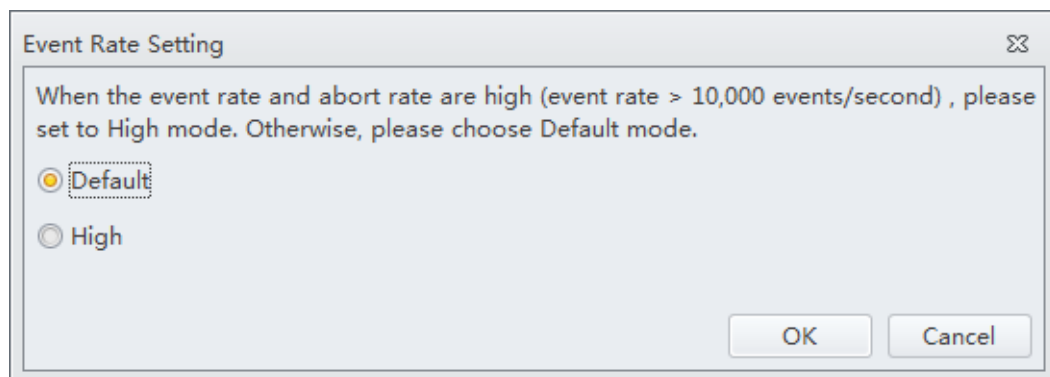

- 2 Select **High** if the event rate is >10,000 events/second.
Or
Select **Default** if the event rate is <10,000 events/second.
- 3 Select **OK**.

Nonscheduled Replacement/Adjustment

Calibrating the Sample Flow Rate

Calibrate the sample flow rate:

- After replacing the sample peristaltic pump tubing.
- If a precise volumetric measurement is required.
The accuracy of concentration calculations can be affected by the sample flow rate.

1 Verify that the instrument is in the initialized state.

2 Select **Calibrate Sample Flow Rate** in the Cytometer menu.

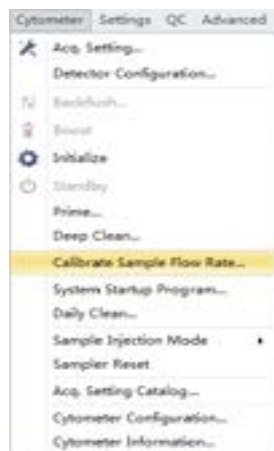

3 Select the flow rate to be calibrated. You can carry out calibration only for one speed and apply it to the setting of all the speeds. At this stage, it is recommended to use a fast speed calibration.



- 4 Use a calibrated electric balance to measure the weight of one sample tube containing at least 1 mL clean deionized water. Record the data and enter it into the software.



The screenshot shows a dialog box titled "Calibrate Sample Flow Rate(Fast)". The text inside reads: "Step1: Please prepare at least 1ml of deionized water, and enter the weight" followed by an empty text input field and a "g" unit. Below that, it says "Acquisition Duration(minutes):" followed by a spin box containing the number "3". At the bottom right, there are two buttons: "Next" and "Cancel".

- 5 Select **Next** and put the sample tube in the sample loading position (see [Figure 1.9](#)).
- 6 Select **Initialize** to start the sample run.

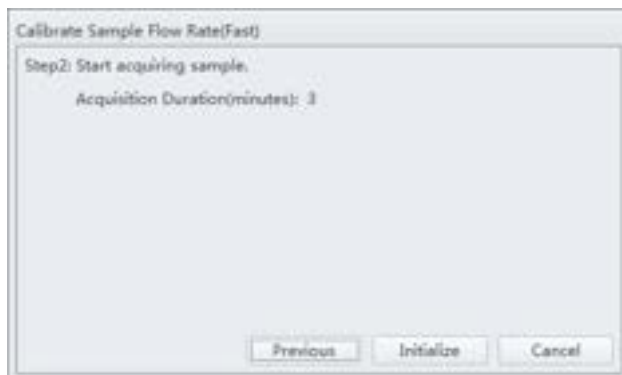

The screenshot shows the same dialog box, now at "Step2: Start acquiring sample." The "Acquisition Duration(minutes):" spin box now displays "3". At the bottom, there are three buttons: "Previous", "Initialize", and "Cancel".

- 7 Select **Run** to begin acquiring the sample.

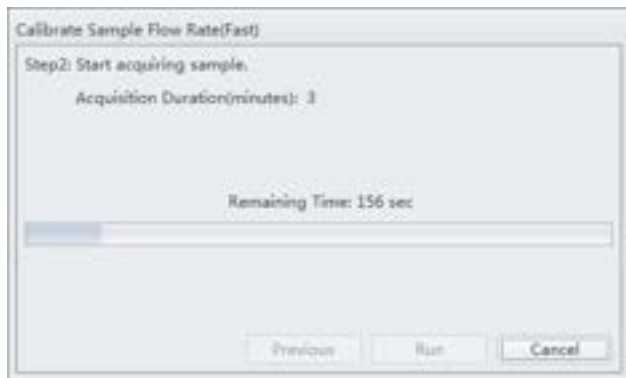
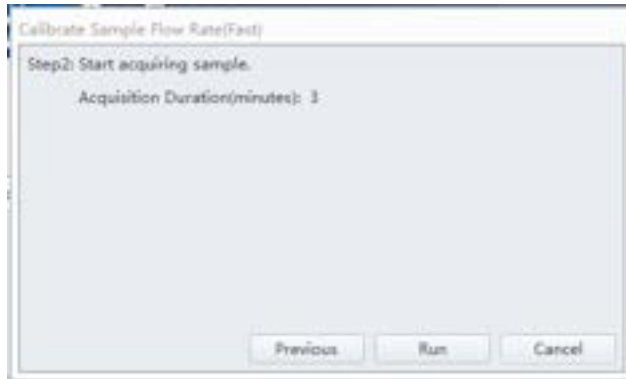

- 8 Wait for the sample run to finish, remove the sample tube, and use the electronic balance to measure the weight and record the value.



- 9 Select **Next** to determine whether the current flow rate is required to be calibrated. According to need, select whether any other flow rate is required to be calibrated.

If no calibration is required, the current setting is kept.



If deviation occurs, the setting is automatically corrected.



Calibrating the Sample Flow Rate [With Plate Loader]

Calibrate the sample flow rate:

- After replacing the sample peristaltic pump tubing.
- If a precise volumetric measurement is required.

The accuracy of concentration calculations can be affected by the sample flow rate.

- 1 Verify that the instrument is in the initialized state.

- 2 Select **Calibrate Sample Flow Rate** in the Cytometer menu. The plate loader automatically ejects the plate holder stage.

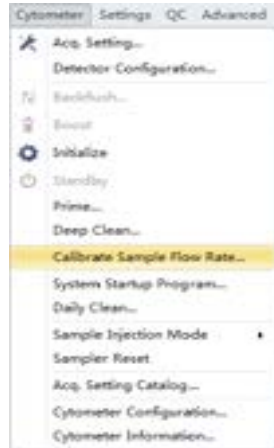

- 3 Select the sampling speed that needs to be calibrated and select **Calibrate**. The Calibrate Sample Flow Rate window appears.



- 4 Follow the onscreen software prompts, then weigh the sample plate.

- 5 Enter the weight of the sample plate and set the acquisition time.

NOTE Do not exceed three minutes when using the fast sampling rate.

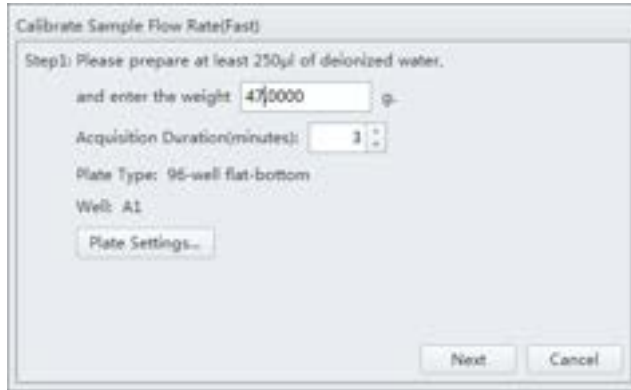

- 6 Select **Plate Settings** to set the sample well and plate type.

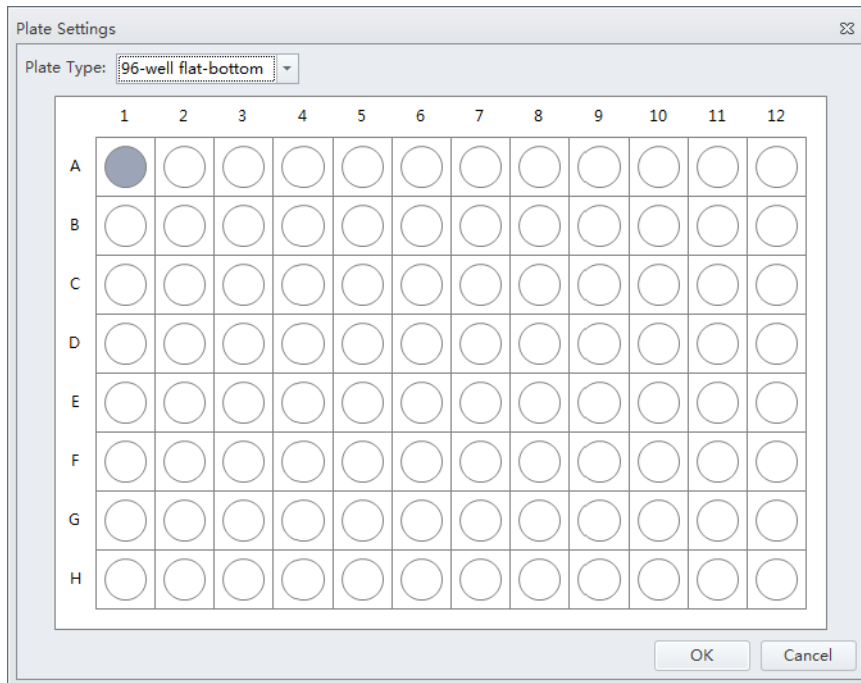

- 7 Select **OK** to save the settings.

- 8 Select **Next** to proceed to the next step. The plate loader automatically ejects the plate holder stage.



- 9 Place the sample plate onto the plate loader.

- 10 Verify the settings and select **Load** to load the plate.

- 11 Select **Run**. The message *Please confirm that the correct plate is placed properly and press OK* appears. Select **OK**. The system begins acquiring the sample.

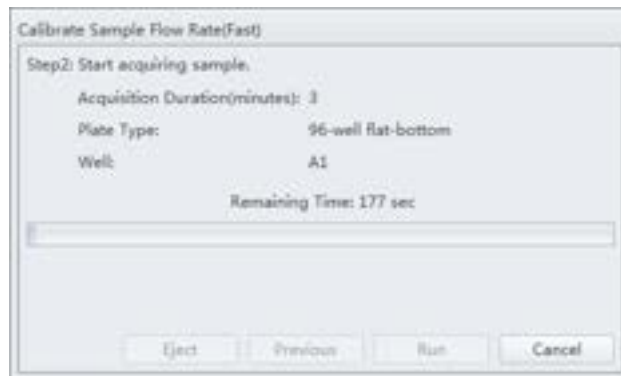

- 12 The plate loader automatically ejects the plate holder stage after the sample is acquired. Weigh the plate.

13 Enter the remaining weight value and select **Next** to confirm the calibration.



14 Select **OK**.



Setting Laser Delay

Laser delay is preset for QC. Only change the laser delay if the software prompts you that there is a difference in the actual delay and the default delay.

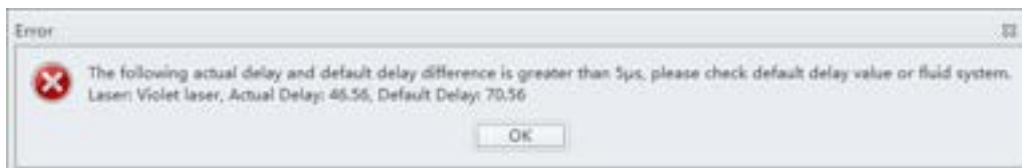

- 1 Select **Delay Setting** from the Advanced menu. The Delay Setting window appears.

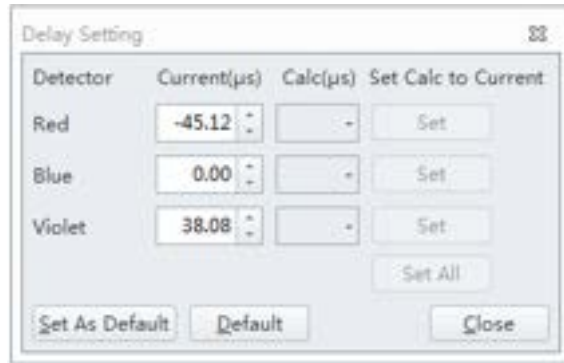

- 2 Set the current to the actual delay for the specified detector stated in the error message received.
- 3 Select **Set as Default**.
- 4 Select **Close**.

Replacing the Optical Filter

When the optical filter is damaged or it is required to use an optical filter with a non-standard wavelength, you must replace the optical filter yourself. For the specific part number of the optical filter, consult your Beckman Coulter Representative or your local dealer.

- 1 Confirm that the instrument is in the standby state or that the instrument is turned off.
- 2 Confirm the laser corresponds to the channel in which the optical filter is to be replaced.
- 3 Open the top cover of the instrument.

- 4 Press the spring piece of the WDM cap corresponding to the laser, and open the WDM cap.

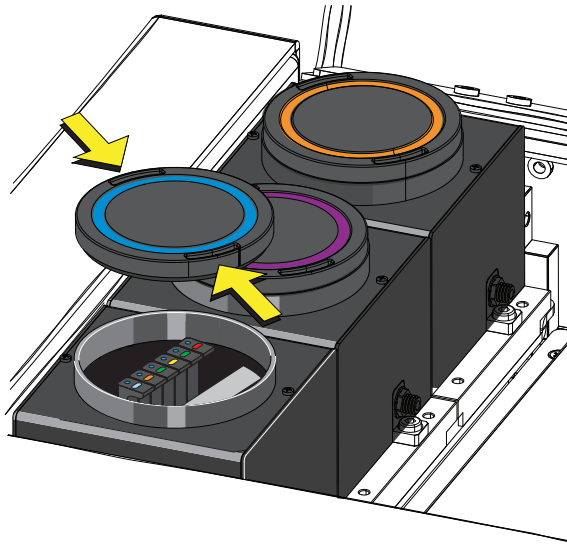

CAUTION

Risk of damage to the optical filter. Do not touch the optical filter glass piece. Touching the optical filter glass piece can obscure and/or scratch the optical filter glass piece.

- 5 Use vertical force to remove the optical filter to be replaced, and note the color identification and wavelength identification on the optical filter bracket.

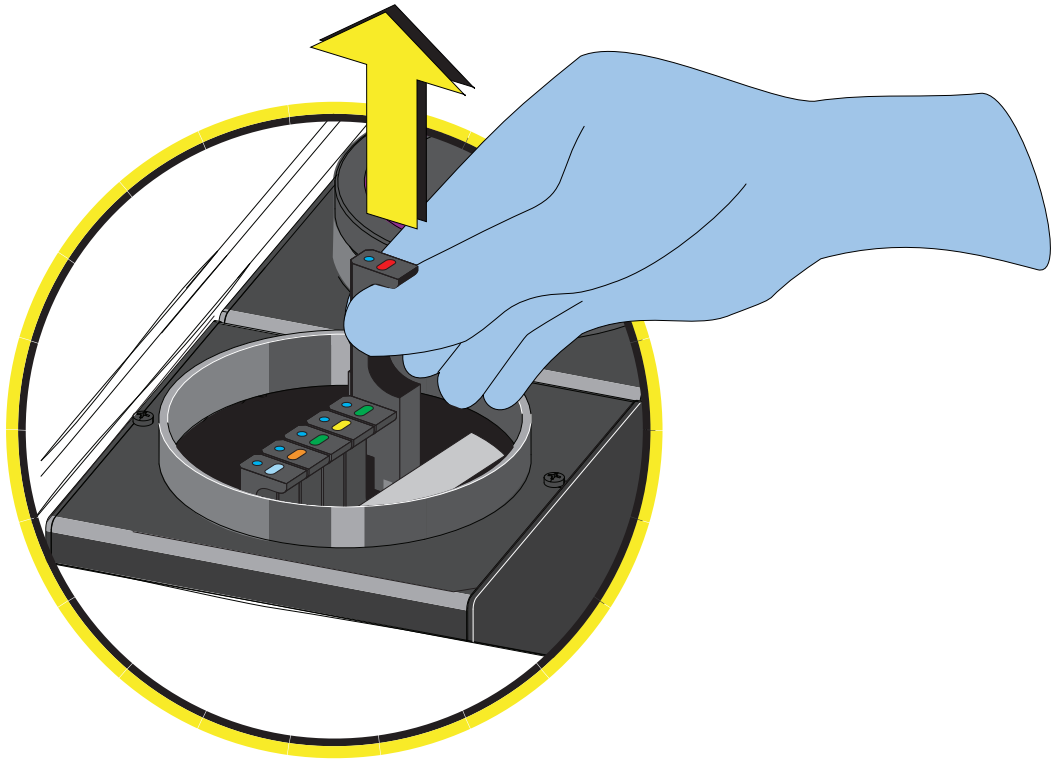

- 6 Insert the optical filter to be installed vertically into the corresponding position, taking care to align the wavelength identification with the left, and that the bracket is inserted into the bottom.

- 7 Close the WDM cap and the instrument top cover.

- 8 Turn on the Cytometer and open the software.

- 9 Select **Detector Configuration** in the Cytometer menu and create a new instrument configuration based on the settings of the new optical filter. Refer to [Verifying, Selecting, Editing, and Creating Detector Configuration](#) in [CHAPTER 5, Data Acquisition and Sample Analysis](#).
Set this new configuration as the current configuration.

Replacing the Fuse

Use a 5 A, time delay, T 5 AL, 250 VAC fuse.



Risk of personal injury. A shock hazard exists if the power cable is connected. Turn off the Cytometer and disconnect the primary power cable before performing these procedures.

- 1 Turn off the Cytometer, and disconnect the power cable.

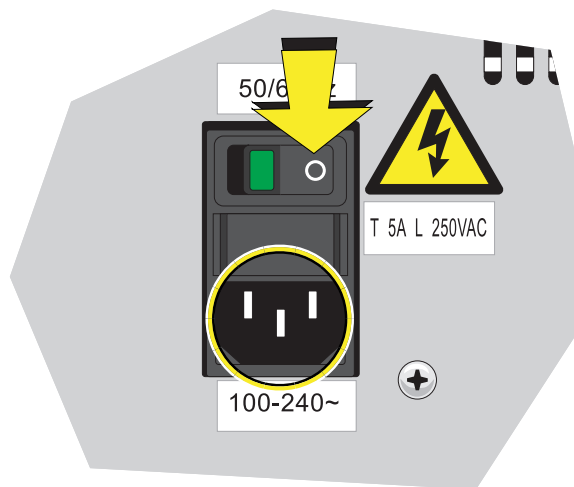

- 2 Press both sides of the fuse holder of the instrument inwards using a flat head screwdriver, and pull out the fuse holder.

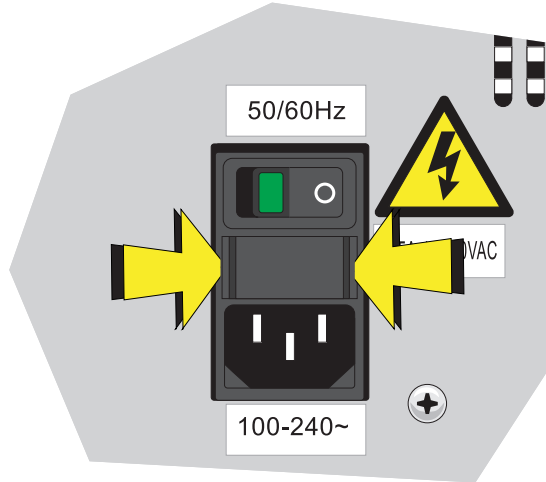

IMPORTANT Select well-performing products that comply with the specifications required, to ensure that the instrument can function normally and safely.

- 3 Check whether the fuse installed is blown, and replace the blown fuse with a new one.
The specifications of the fuse required are: T 5 AL 250 VAC, delay blow fuse, 5A, 250 VAC, 5 x 20 mm. Beckman Coulter recommends using SCHURTER 0034.3124.



- 4 Insert the fuse holder.

-
- 5 Reconnect the power cable.
-

Replacing the Sheath Fluid Harness and/or Waste Harness

Replace the sheath fluid harness and/or the waste harness if you have a faulty sheath fluid sensor and/or waste sensor.

-
- 1 Confirm that the instrument is turned off or is in the standby state.
-
- 2 Remove sheath and/or waste pickup tubing from the appropriate container.
-
- 3 Disconnect the blue harness (1) from the sheath fluid container (2) and/or the yellow harness (3) from the waste container (4) from the fluid connector panel (5) on the back right corner of the instrument according to the color code.

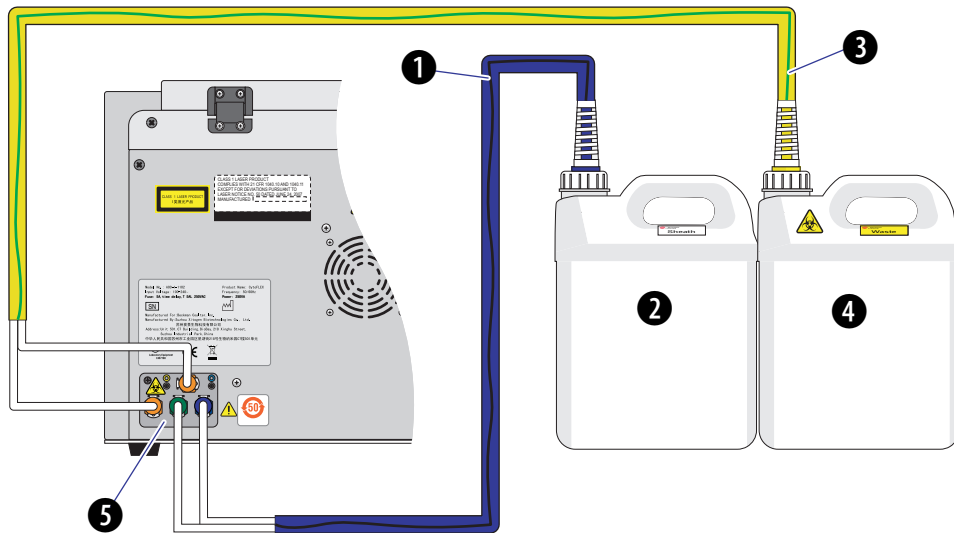

Disconnect the waste (1) and/or sheath (2) level sensors.

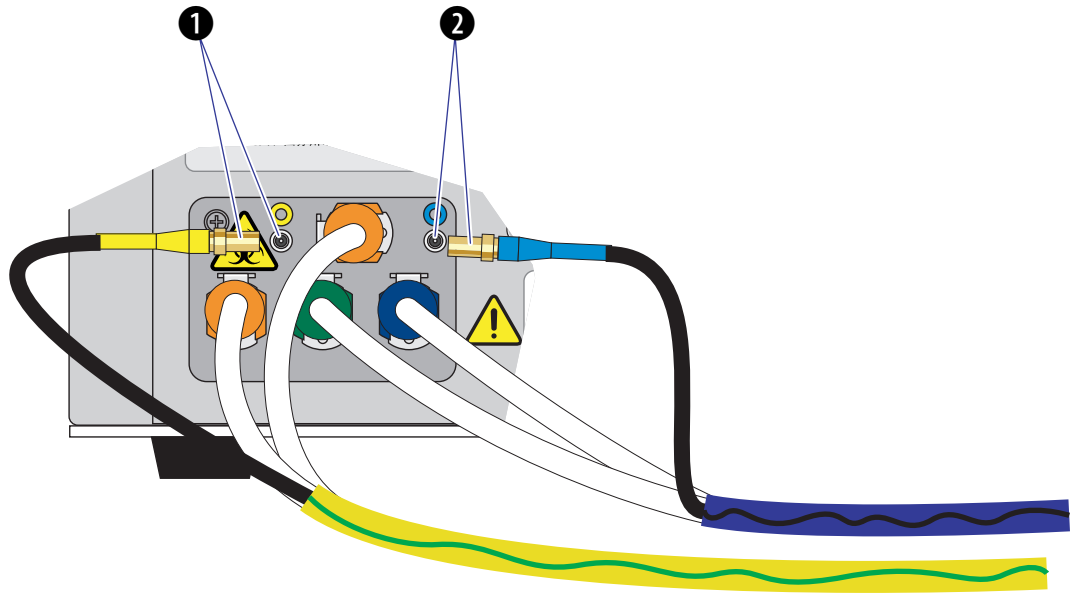

- 4 Dispose of the sheath fluid harness and/or the waste harness according to your laboratory procedures.
- 5 Insert the new sheath and/or waste pickup tubing into the appropriate container.
- 6 Connect the blue harness (1) from the sheath fluid container (2) and/or the yellow harness (3) from the waste container (4) to the fluid connector panel (5) on the back right corner of the instrument according to the color code.

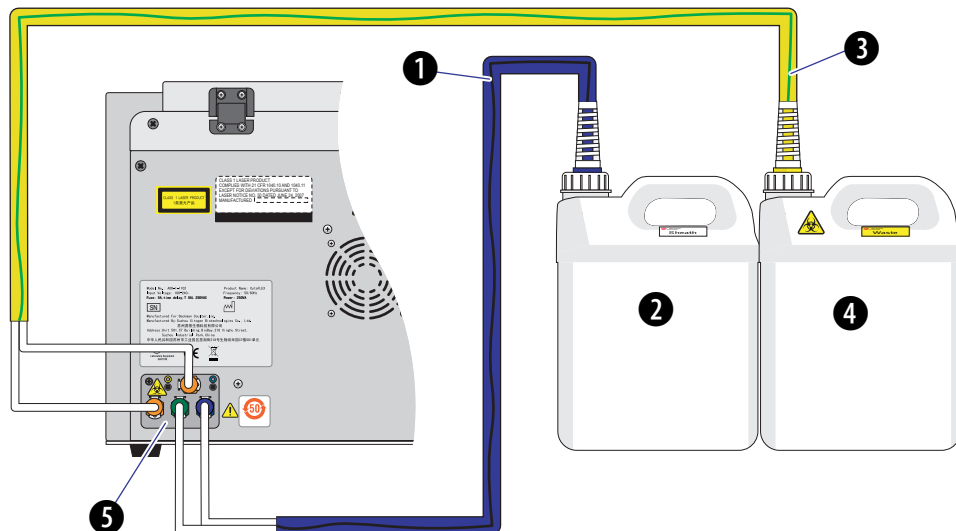

Connect the waste (1) and/or sheath (2) level sensors.

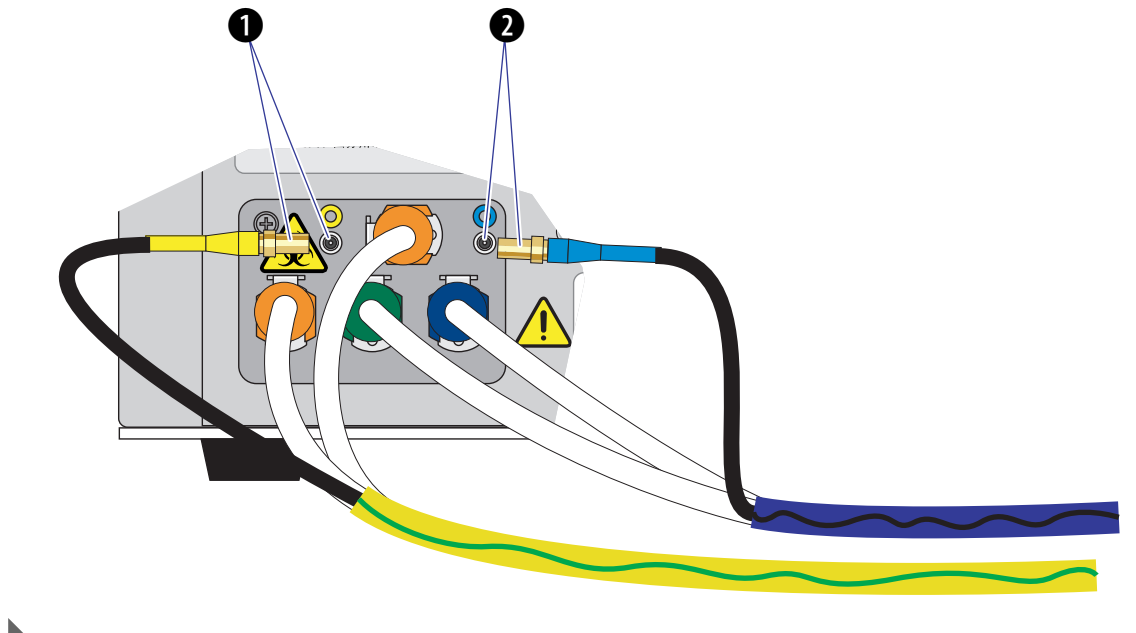

Changing Sample Mixing and Backflush Settings

WARNING

Risk of biohazardous contamination. Enabling sample mixing for 1.5-mL and 2-mL sample tubes in the semi-automatic sample injection mode can result in sample splashing. Exceeding 300- μ L sample volume when using 1.5-mL and/or 2-mL sample tubes can also result in sample splashing. Disable sample mixing in the semi-automatic sample injection mode when using 1.5-mL and 2-mL sample tubes and do not exceed 300- μ L sample volume.

The sample mixer can be enabled or disabled if necessary. The sample mixing duration can also be increased or decreased if necessary.

Whenever a sample is likely to leave residue or cause contamination, the backflush time can be increased to reduce cross contamination.

- 1 Open the CytExpert software and confirm that the instrument is connected. Refer to [Opening the Software](#) in [CHAPTER 3, Daily Startup](#).

- 2 Select **Cytometer Configuration** in the Cytometer menu. The Cytometer Configuration window appears.



- 3 Select the Sample Mixing check box to enable sample mixing.
Or
Deselect the Sample Mixing check box to disable sample mixing.

- 4 Change the sample mixing duration to the desired time.

NOTE The default setting is 1 second. Select **Default** to set the Cytometer configuration settings back to the factory default settings.

- 5 Change the backflush duration to the desired time for either the Manual/Semi-Automatic sample injection mode or the Plate Loader sample injection mode depending on the current sample injection mode selected.

NOTE The default setting is 3 seconds. Select **Default** to set the Cytometer configuration settings back to the factory default settings.

- 6 Select **OK**.

Calibrating the Plate Position [With Plate Loader]

Use the following procedure to calibrate the plate position and the sample probe position:

- Upon installation
- After a new plate type is defined for first use
- After changing plate manufacturers of the same previously calibrated plate type
- When optimizing plate performance

1 Remove the front cover. Refer to [Front Cover Removal and Reinstallation](#) in [CHAPTER 11, Replacement/Adjustment Procedures](#).

2 Select **Calibrate Plate** in the Advanced menu. The plate loader automatically ejects the plate holder stage and the Calibrate Plate window appears.

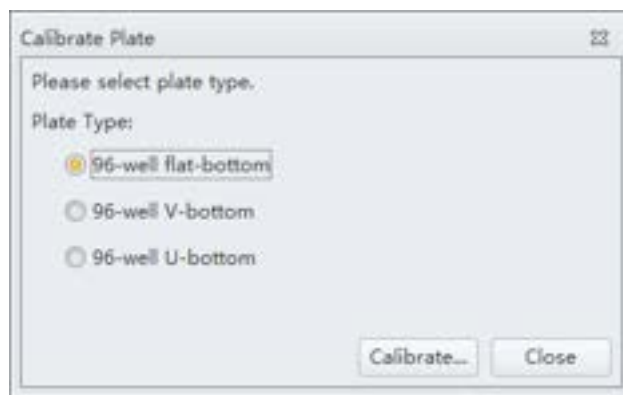

3 Select the plate type and place the plate on the plate holder.

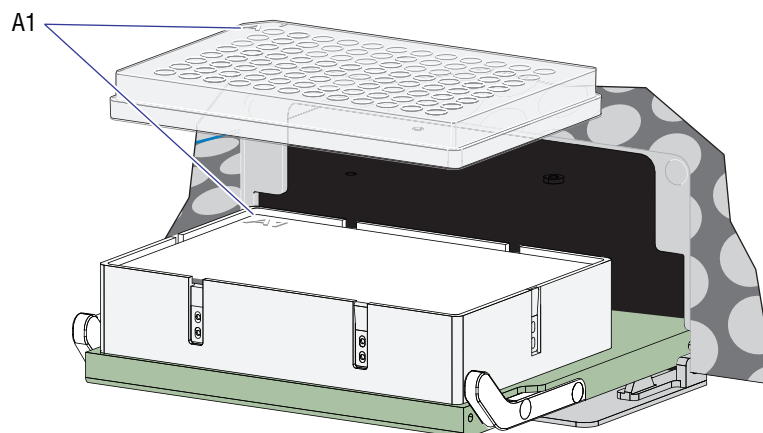

NOTE Ensure plate well A1 aligns with position A1 on the plate holder.

- 4 Select **Calibrate**. The message *Are you sure the plate is loaded?* appears. Select **OK**. The plate loader loads the plate holder stage and the sample probe moves to the sample aspiration position of well A1.

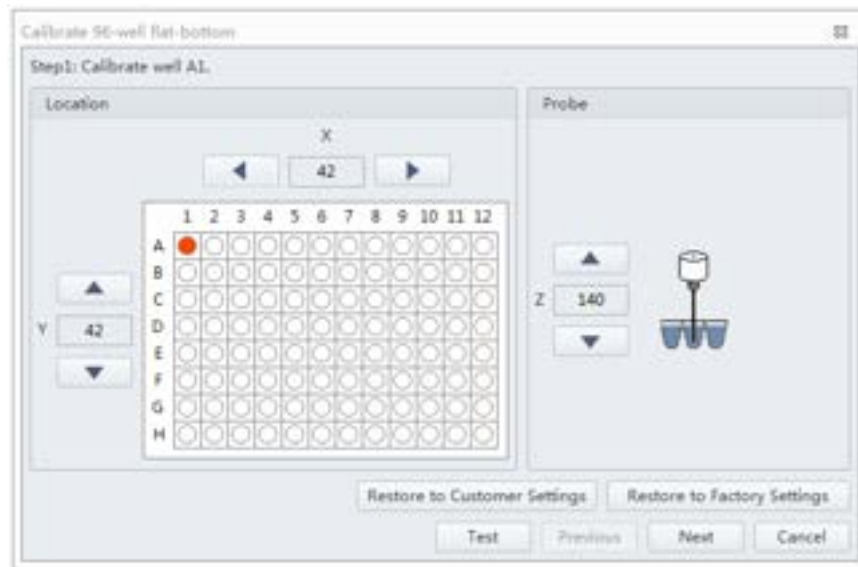
**CAUTION**

Risk of instrument damage. Do not crash the probe into the bottom of the plate as this will cause irreparable damage. Move the probe one step at a time when lowering the probe on the Z-axis toward the bottom of the plate. You will hear a click when the probe makes contact with the bottom of the well, this is the correct position for the Z-axis of the probe. Do not move the probe any lower after you hear the click.

- 5 Select  and  or  and  to adjust the sample probe positions in the X-, Y-, and Z-axes.

Ensure the sample probe is centered and touches the bottom of the well.

NOTE The sample probe should just make contact with the bottom of the well.

NOTE The X-axis arrows moves the sample probe well position left and right. The Y-axis arrows moves the sample probe well position forward and back. The Z-axis arrows moves the sample probe up and down.

- 6 Select **Test** to verify the sample probe position.

Listen for the click to ensure the probe has made contact with the bottom of the well. Readjust the sample probe position if necessary.

- 7 Select **Next** to move to the next well.
- 8 Repeat Steps 5-7 for wells A12, H1, and H12.

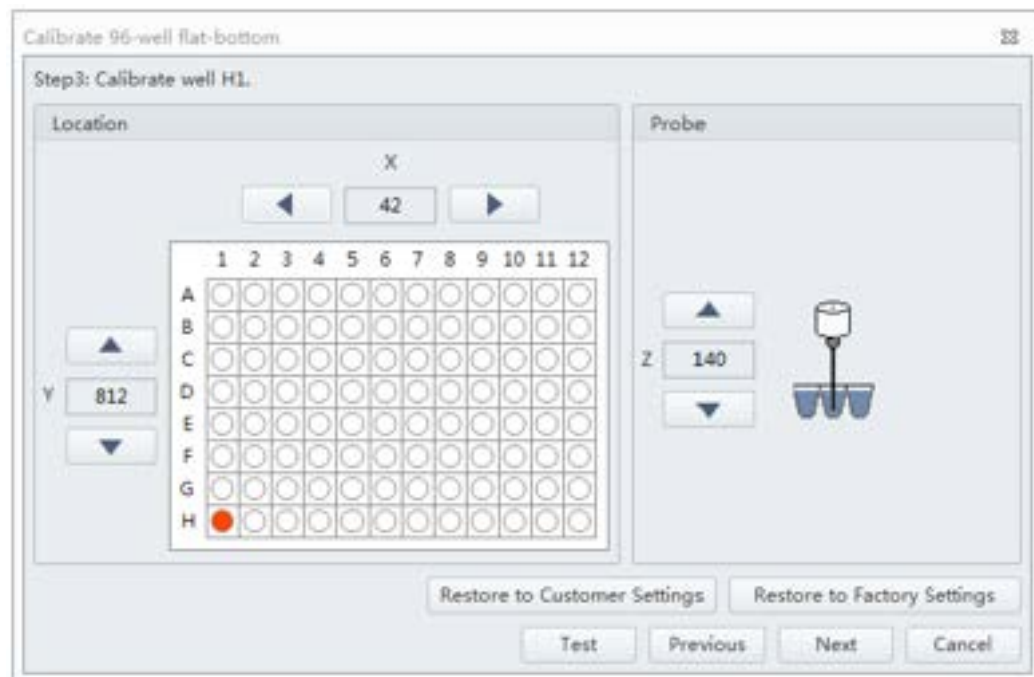
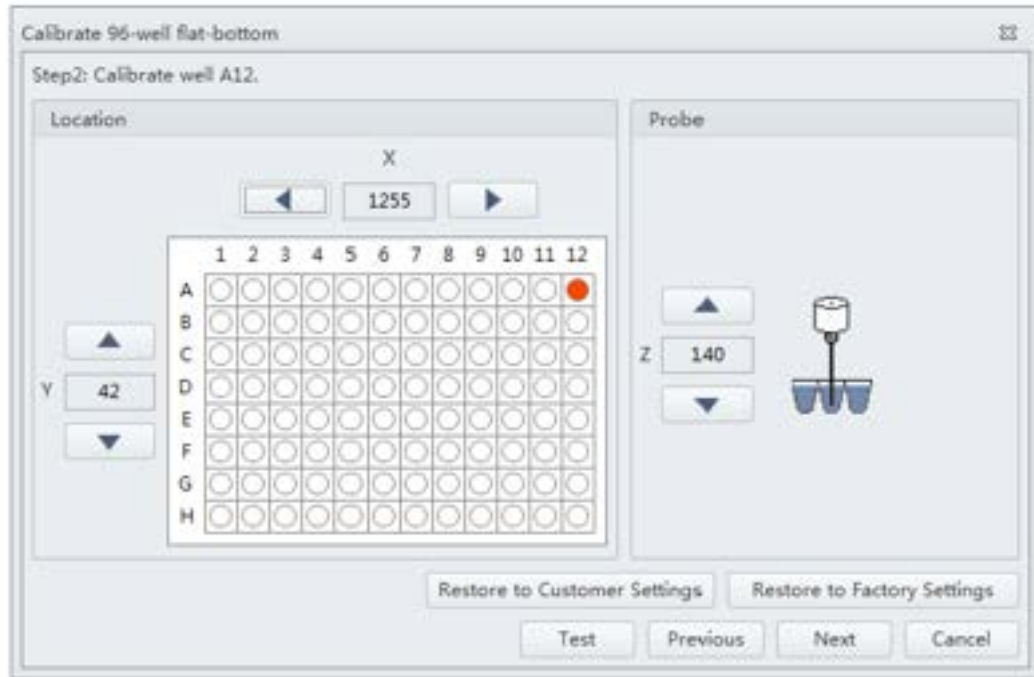

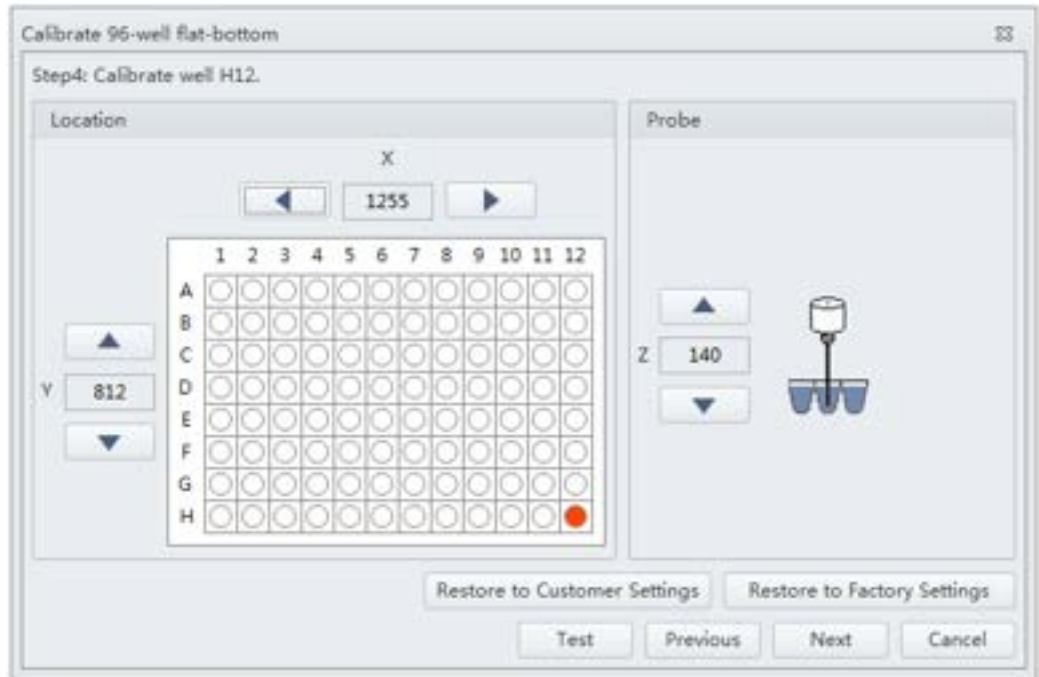

- 9 Select additional plate types to be calibrated on the Calibration completed window, if necessary. Place the corresponding plate on the plate holder and repeat Steps 5-8.

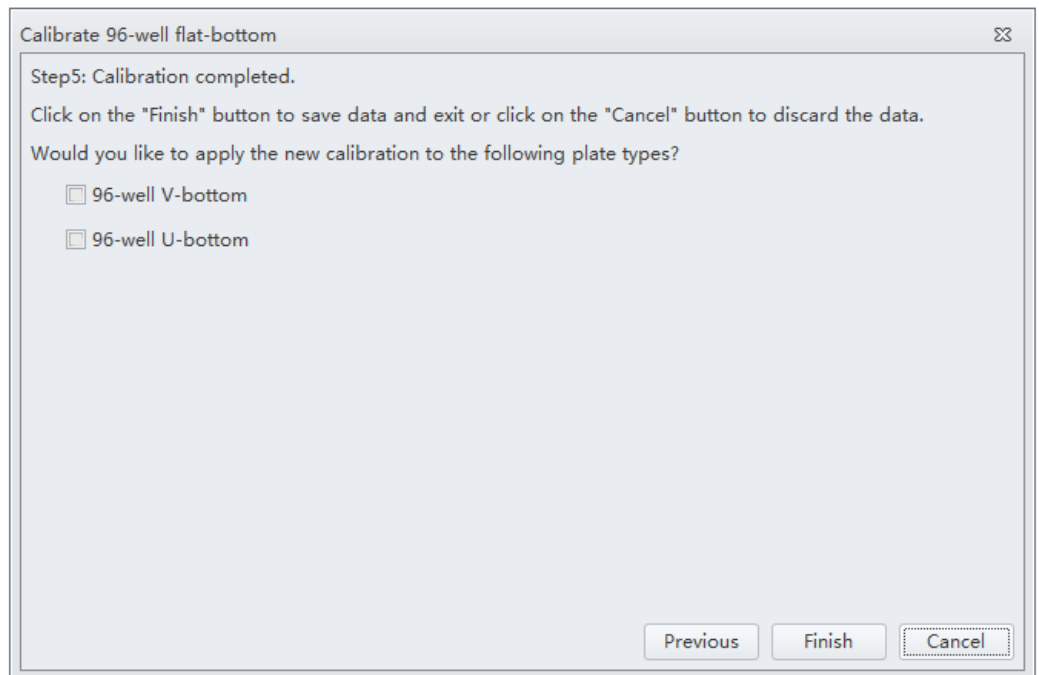

- 10 Select **Finish** to save the settings.

11 Select **Close** to quit the program.

12 Reinstall the front cover. Refer to [Front Cover Removal and Reinstallation](#) in **CHAPTER 11, Replacement/Adjustment Procedures**.

Overview

Your instrument may have been shipped directly to your laboratory, in which case you will need to set up and connect the Cytometer and the Workstation. Refer to this chapter for the instrument installation procedure.

Validate the environment	→	Open the package	→	Install the instrument	→	Prepare to boot
--------------------------	---	------------------	---	------------------------	---	-----------------

This chapter contains information on:

- [Instrument Transportation and Storage](#)
- [Installation Environment Validation](#)
- [Unpacking the Instrument and Inspecting the Materials for Defects or Omissions](#)
- [Installing the Software](#)

Instrument Transportation and Storage

Refer to [Preparing the Instrument for Transport or Storage](#) in [CHAPTER 10, Cleaning Procedures](#), prior to transportation or storage.

Attention to the following items is required when transporting or storing the instrument:

- Take caution to protect the instrument from exposure to rain or sunlight.
- Always place the instrument on a flat, stable surface, and take note of the symbol for *this side up*.
- Temperature range: see [Temperature and Humidity](#).
- To prevent extrusion, the load on top cannot exceed 100 kg.
- Cytometer net weight 23 kg, gross weight 27 kg; transport the instrument using only appropriate equipment so as to guard against personal injury.

Installation Environment Validation

IMPORTANT This instrument is intended for indoor use only.

Verify whether the installation environment satisfies the following requirements:

Worktable



Risk of instrument damage. Place the instrument on a level surface. Failing to do so places the system in danger of toppling and can result in damage. Take all necessary precautions throughout the process of storing or transporting the instrument.

- The tabletop must be smooth and level.
- Minimum tabletop load bearing capacity: 50 kg.
- The tabletop must not vibrate or shake.
- Minimum tabletop dimensions: 120 cm x 80 cm; minimum vertical space above tabletop: 80 cm
- Position the instrument in such a manner that it will facilitate disconnection of the power cable at the instrument end.

Ventilation and Cleaning

IMPORTANT If necessary, use ventilation equipment, but airflow must not be allowed to blow directly on the system, as it can affect the reliability of the data.

- Ensure that the working environment is well ventilated for proper heat dissipation.
- Maintain a clearance of at least 20 cm from the back of the instrument for heat dissipation.
- Keep the environment as dust free as possible.
- Avoid direct exposure to sunlight.
- Avoid placing near heat sources or exposing to drafts.
- Avoid corrosives or flammable gases.

Power Source



DANGER

Risk of electric shock and/or instrument damage. Ensure that the power source is properly grounded. Improper grounding can cause electric shock and damage the system. Verify that the output voltage of the power outlet conforms to the system requirements and that a 5 A, time delay, T 5 AL 250 VAC fuse is installed. To prevent personal injury, Beckman Coulter recommends using a power source designed to protect against electrical shock.



CAUTION

Possible instrument damage could occur if you use an extension cord or a power strip to connect the Cytometer. Always plug the Cytometer into a dedicated outlet with an isolated ground.

The power source requirements are as follows:

- This instrument has been tested to and meets all applicable requirements for CE Marking.
- This instrument complies with the emission and immunity requirements described in IEC 61326-1 and 61326-2-6 series.
- This equipment has been designated and tested to CISPR 11 Class A. In a domestic environment it may cause radio interference, in which case, you may need to take measures to mitigate the interference.
- It is advised that the electromagnetic environment should be evaluated prior to operation of the device.
- Do not use this device in close proximity to sources of strong electromagnetic radiation (unshielded intentional RF sources), as these may interfere with the proper operation.
- 100-240 volts, 50/60 Hz, 3-wire power cable, well grounded.
- Amperage not less than 10 A.
- The system requires a well-grounded power outlet (150 VA normal, 250 VA max) to provide the necessary power.
- Distance from system to socket less than 1.5 m.

Power consumption of the Plate Loader is <30 W.

Temperature and Humidity



Risk of instrument damage and/or erroneous results. To ensure reliability, the system must be operated in the specified environment, within the required temperature and humidity ranges. If the ambient temperature or humidity level falls outside the ranges mentioned above, use appropriate air conditioning.

- Ambient temperature: 15-27°C with fluctuations of no more than $\pm 2^\circ\text{C}$ per hour.
- Relative humidity: 15% RH-80% RH, non-condensing.

Waste Disposal



Risk of biohazardous contamination if you have skin contact with the waste container, its contents, and its associated tubing. The waste container and its associated tubing might contain residual biological material and must be handled with care. Clean up spills immediately. Dispose of the contents of the waste container in accordance with your local regulations and acceptable laboratory procedures.

Dispose of the system's waste in accordance with your local regulations and acceptable laboratory procedures.

Unpacking the Instrument and Inspecting the Materials for Defects or Omissions

Take care to store the instrument in a suitable environment where it can remain in the proper position.

Check that the following components on the packing list are present:

- Cytometer
- Cables
- Computer
- Mouse
- Keyboard
- Monitor
- Sheath fluid container
- Waste container
- Sheath fluid tubing

- Waste tubing
- USB configuration key
- Software USB

Installing the Instrument and Connecting the Equipment

IMPORTANT Use the appropriate power cable plus for your geographic region.

 **CAUTION**

Risk of erroneous results. Place the Fluid Containers and the instrument on the same, level surface. An excessive difference in height can alter the flow velocity.

 **CAUTION**

Possible instrument damage could occur if you use an extension cord or a power strip to connect the Cytometer. Always plug the Cytometer into a dedicated outlet with an isolated ground.

-
- 1 Remove the Cytometer, the Fluid Containers, the accompanying holder, the computer, the monitor, and the keyboard and mouse from the each respective box placing them flat on the instrument worktable.

NOTE The Fluid Container holder must be on the same plane as the Cytometer.

Reach under the base of the instrument to lift the Cytometer out of the package. Beckman Coulter recommends that two people lift the Cytometer out together.

-
- 2 Ensure a minimum clearance of 20 cm on both sides and to the back of the Cytometer to maintain enough room to access the on/off controls for the Cytometer devices.

- 3** After removing the monitor and attaching the base, place them on the worktable with the computer.

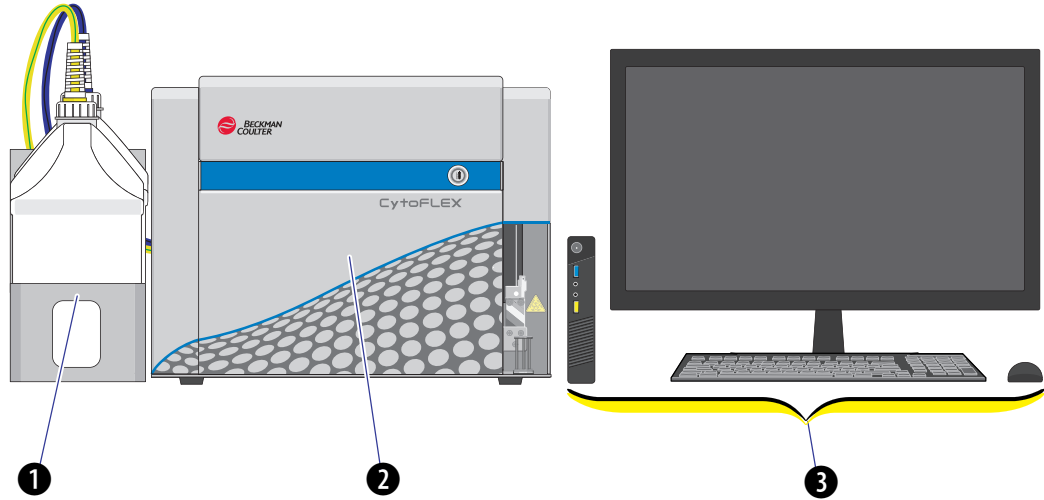

- 1. Fluid Containers.** Place on the left side of the Cytometer.
- 2. Cytometer.** Place between the Fluid Containers and the Workstation.
- 3. Workstation.** Place on the right side of the Cytometer.

- 4** Open the top cover of the Cytometer. Check inside to verify that the optical bench cover (1) is tightly closed and that the optical fibers (3) and WDMs (2) are securely connected.

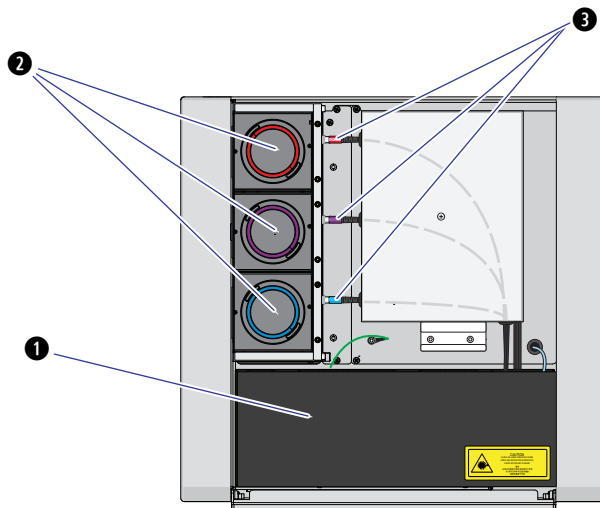

- Remove any shipping tape and open the cap of each WDM. Verify that the light filters inside are in place.

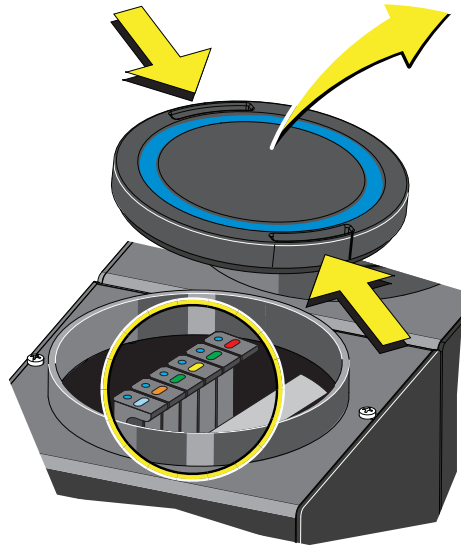

- Insert sheath and waste pickup tubing into the appropriate container.

- Connect the blue harness (1) from the sheath fluid container (2) and the yellow harness (3) from the waste container (4) to the fluid connector panel (5) on the back right corner of the Cytometer according to the color code.

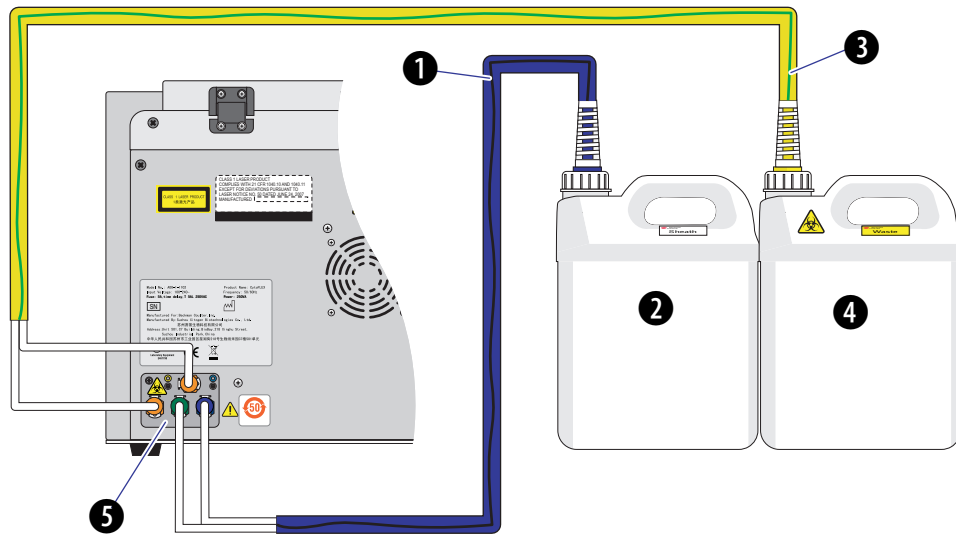

-
- 8** Connect the waste (1) and sheath (2) level sensors.

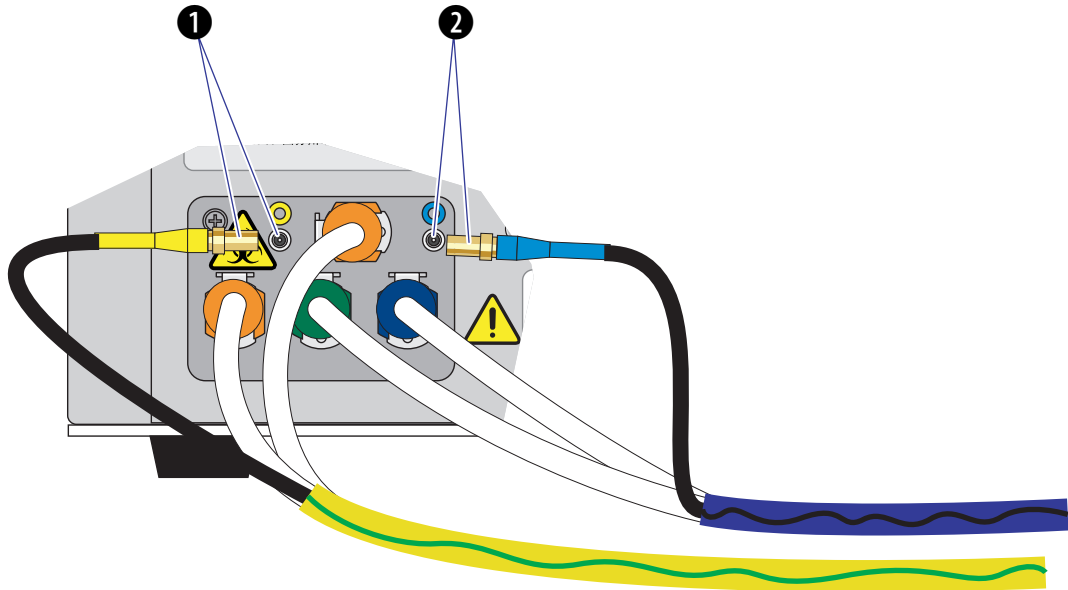

-
- 9** Place the sheath fluid container (1) and the waste container (2) in the Fluid Container holder (3).

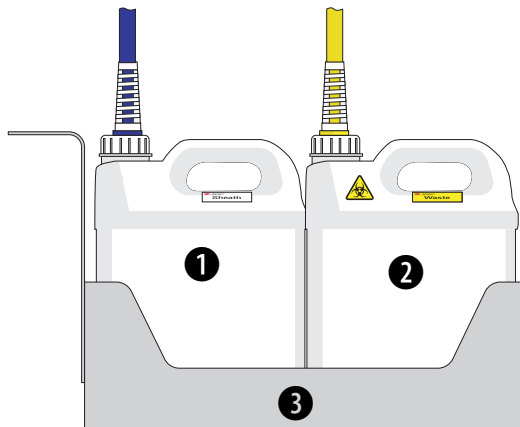

- 10** Set up the supplied computer (1) and connect the USB cable (2) from the back of the Cytometer (3) to a USB port on the back of the computer.

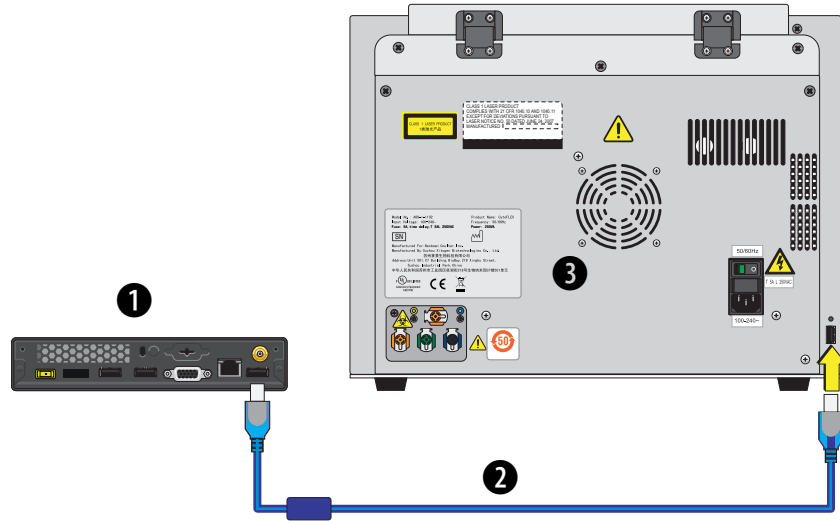

- 11** Plug the Cytometer power cable in to the back of the Cytometer.

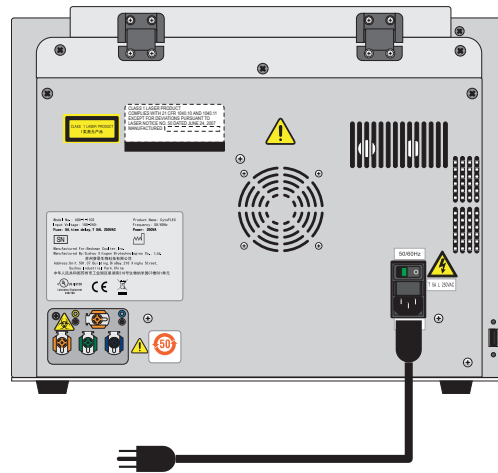

- 12** Connect the computer keyboard, mouse, and monitor.

-
- 13** Remove the foam support holding the sample loader in the front-right corner of the instrument.

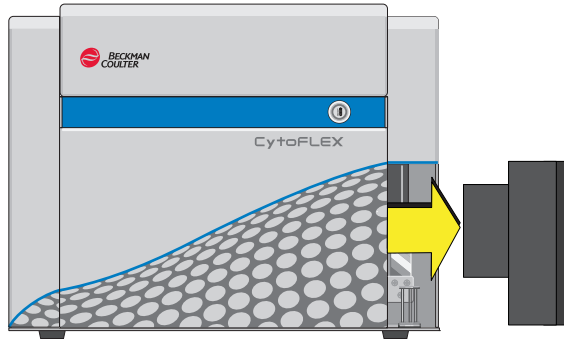

-
- 14** Add Deep Clean solution to the Deep Clean solution bottle. Refer to [Adding the Deep Clean Solution](#) in [CHAPTER 11, Replacement/Adjustment Procedures](#).
-
- 15** Clean the sheath fluid container. Refer to [Cleaning the Sheath Fluid Container](#) in [CHAPTER 10, Cleaning Procedures](#).
-
- 16** Fill the Sheath fluid container. Refer to [Filling the Sheath Fluid Container](#) in [CHAPTER 11, Replacement/Adjustment Procedures](#).

⚠ WARNING

Risk of chemical injury from bleach. To avoid contact with the bleach, use barrier protection, including protective eyewear, gloves, and suitable laboratory attire. Refer to the Safety Data Sheet for details about chemical exposure before using the chemical.

-
- 17** Add 400 mL of 5 to 6% bleach to the waste container.
-
- 18** Install the CytExpert software. Refer to [Installing the Software](#).
-
- 19** Turn on the instrument. Refer to [Turning On the Instrument](#) in [CHAPTER 3, Daily Startup](#).
-
- 20** Open the CytExpert software. Refer to [Opening the Software](#) in [CHAPTER 3, Daily Startup](#).
-
- 21** Run the System Startup Program. Refer to [Running the System Startup Program](#) in [CHAPTER 3, Daily Startup](#).

-
- 22** Prime the instrument three times.
-
- 23** Prepare a QC sample. Refer to [Preparing the QC Sample](#) in [CHAPTER 4, Instrument Quality Control](#).
-
- 24** Import the lot-specific target values files. Refer to [Importing Lot-Specific Target Values](#) in [CHAPTER 4, Instrument Quality Control](#).
-
- 25** Perform a QC to establish the target gain values for your instrument. Refer to [Collecting QC Data](#) in [CHAPTER 4, Instrument Quality Control](#).
-
- 26** If QC fails, the following software message appears. Select **Yes**.



NOTE Target gain values must be established upon installation. QC could fail up to 3 times upon installation until target gain values are established.

-
- 27** Repeat Steps [23-26](#) until the target gain values are established and QC has passed.
- NOTE** If QC fails more than three times, contact your Beckman Coulter Representative.
-
- 28** Within five business days, activate your Warranty by contacting your local Beckman Coulter Representative and providing them with your latest QC run results.
-

Installing the Software

The installation process workflow is as follows:

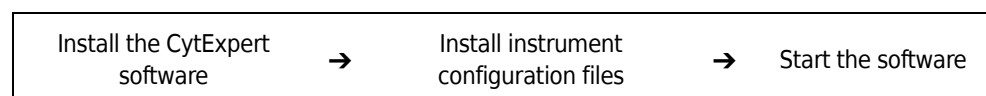

The CytExpert software can be installed on a computer that meets the minimum specifications (see [Instrument Specifications](#) in [CHAPTER 1, System Overview](#)) for analysis-only use.

Required materials

The following materials are required to install the CytExpert software:

- CytoFLEX flow cytometer.
- CytoFLEX Workstation.
- CytExpert software installation USB.
- Authorized Beckman Coulter USB configuration key.

Installing the CytExpert Software

- 1 Insert the software USB into the computer.

NOTE If the Autoplay window appears, select Open folder to view files.

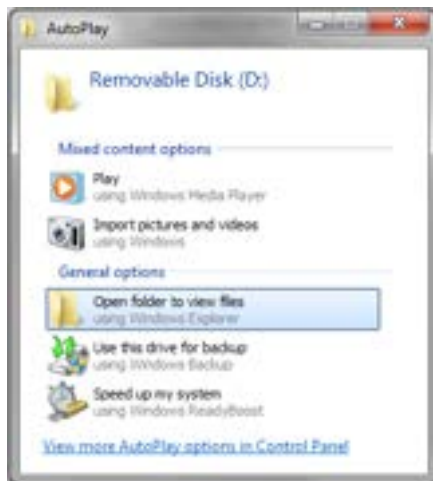

- 2 Select **CytExpert_1.1_Setup.exe**. The CytExpert Setup Welcome window appears.



A User Account Control message may display the message *Do you want to allow the following program from an unknown publisher to make changes to this computer.* Select **Yes** to continue.

- 3 Select **Next**.
- 4 Select all three support program check boxes in the CytExpert Setup Prerequisites window.

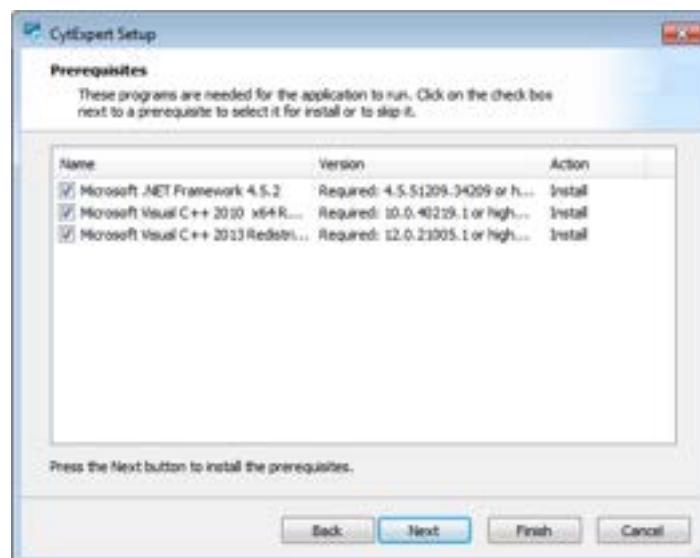

- 5 Select **Next**. The Microsoft .NET Framework window appears.



- 6 Select the *I have read and accept the license terms* check box.

- 7 Select **Install**. The Installation is Complete window appears when installation has finished.

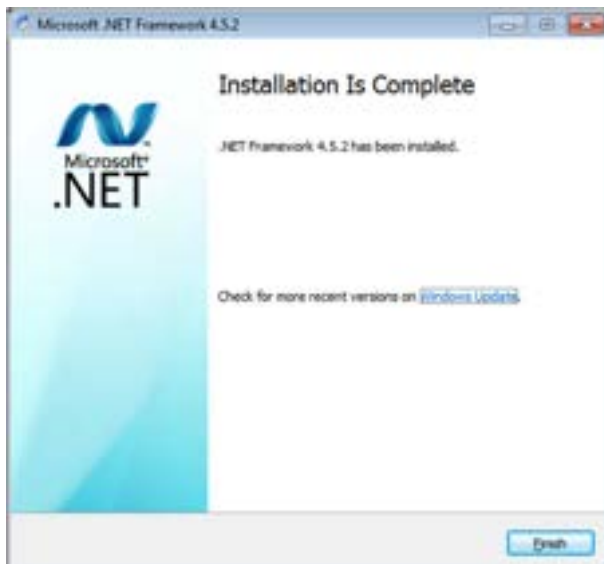

- 8 Select **Finish**. The Microsoft Visual C++ 2010 x64 Redistributable Setup window appears.



- 9 Select the *I have read and accept the license terms* check box.

- 10 Select **Install**. The Installation is Complete window appears when installation has finished.

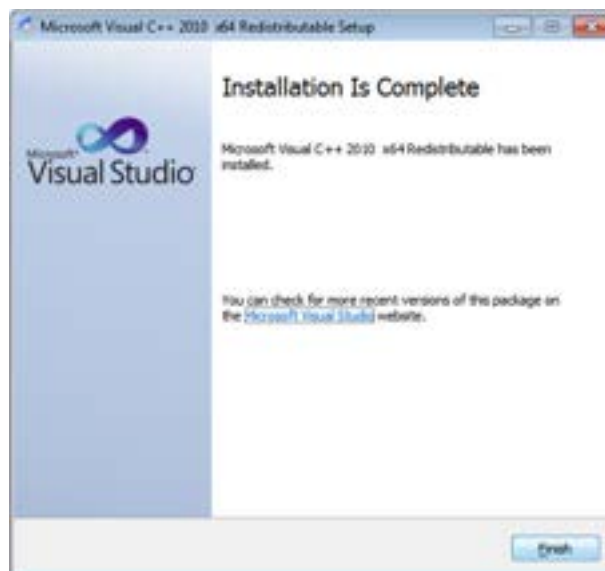

-
- 11 Select **Finish**. The Microsoft Visual C++ 2013 Redistributable (x64) window appears.

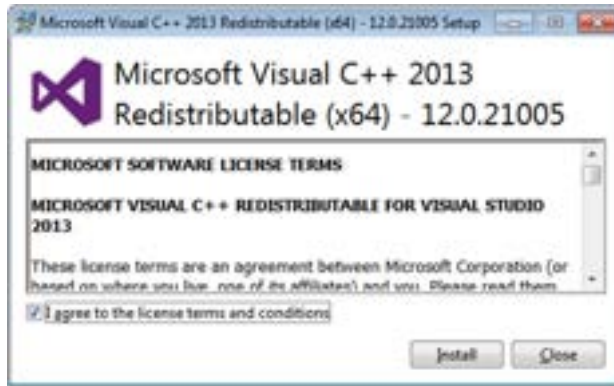

-
- 12 Select the *I have read and accept the license terms* check box.

-
- 13 Select **Install**. The Installation is Complete window appears when installation has finished.

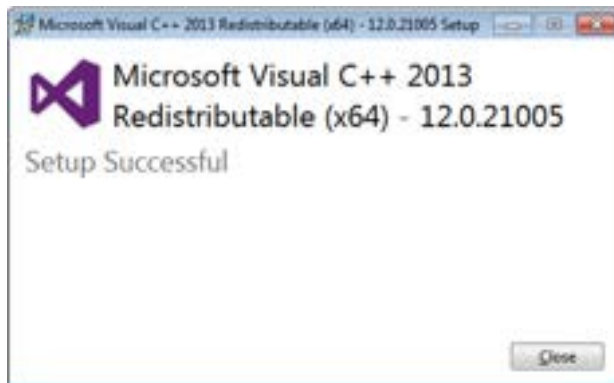

- 14 Select **Close**. The Welcome to CytExpert Setup Wizard window appears.



- 15 Select **Next**. The Beckman Coulter License Terms window appears.



- 16 Read the Beckman Coulter Customer End User License Agreement.

17 Select the *I accept the terms of this agreement* check box.

NOTE The checkbox is not selectable until you scroll all the way to the end of the agreement.

18 Select **Next**. The Begin installation of CytExpert window appears.



19 Select **Next**. The Choose a file location window appears.

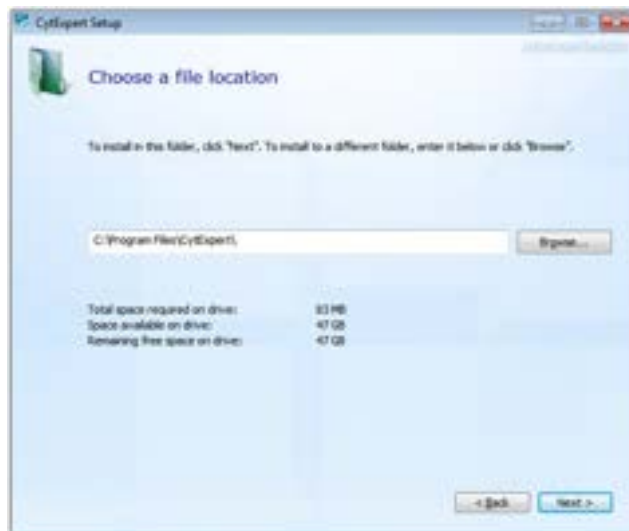

20 Select **Install** to begin installing the software. The Installation Progress window appears.

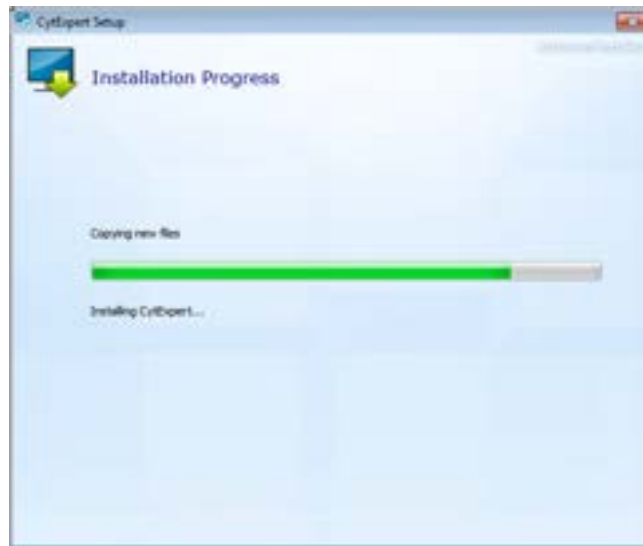

NOTE The software will install into the default file path provided unless otherwise specified.

21 A Windows Security window appears. Select *Install this driver software anyway* to install the USB drive.



22 The following software prompt appears.



Select **OK**.

23 Wait for the software to finish installing. The install complete window appears.

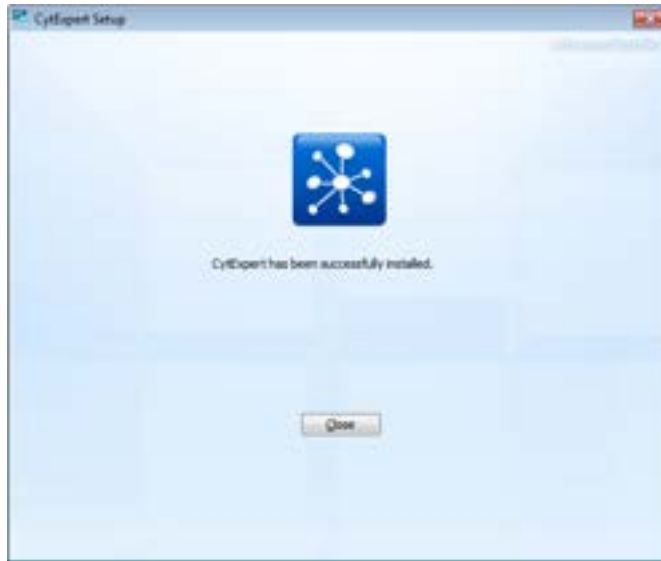

24 Select **Close** to finish the CytExpert software installation.

25 Install the instrument configuration file. Refer to [Installing the Instrument Configuration File](#).

Installing the Instrument Configuration File

CAUTION

Risk of erroneous results or instrument damage. Only install the configuration file that matches your instrument. Installing an incorrect configuration file could cause erroneous results or instrument damage.

Use this procedure to install the configuration settings for the instrument. If the CytExpert software will not be connected to a Cytometer, this step can be skipped.

IMPORTANT You must install the CytExpert software before installing the instrument configuration file. Refer to [Installing the Software](#).

- 1 Select and run **CytExpert_1.1_Config_Setup_XXXX.exe**. The CytExpert Config Welcome window appears.

NOTE XXXX refers to the serial number of the instrument.



- 2 Select **Next**. The CytExpert Config Ready to Install window appears.



- 3 Verify that the serial name displayed at the top of the window is correct.

- 4 Select **Install**. When the installation has finished, the Completing the CytExpert Config Setup Wizard window appears.



- 5 Select **Finish**.

Starting the Software

- 1 Insert the USB configuration key into the USB port of the computer.
- 2 Start the software. Refer to [Opening the Software](#) in [CHAPTER 3, Daily Startup](#), for detailed instructions on opening the software and confirming the connection status.

NOTE If the software shows *Connected*, data collection and analysis can be completed.

Table of Hazardous Substances

Table of Hazardous Substances

The Hazardous Substances Names and Concentration is shown in [Table B.1](#)

Table B.1 有毒有害物质名称及含量的标识格式 Table of Hazardous Substances Name and Concentration

电子信息产品号码 EIP Part Number: A00-1-1102	产品名称 Product Name: CytoFLEX 产品型号 Product Model Number: A00-1-1102					
部件名称 Component Name	有毒有害物质或元素 Hazardous Substances Name					
	铅 (Pb)	汞 (Hg)	镉 (Cd)	六价铬 (Cr ⁶⁺)	多溴联苯 (PBB)	多溴二苯醚 (PBDE)
印刷电路板组件 Circuit Boards	X	0	0	0	0	0
电源组件 Power Supplies	0	0	0	0	0	0
计算机 Computer	0	0	0	0	0	0
功率调节器 Power Conditioner	0	0	0	0	0	0
光学传感器 Optical Sensors	0	0	0	0	0	0
激光 Laser	0	0	0	0	0	0
发动机/泵/阀门/ Motors/Pumps/Valves	0	0	0	0	0	0
电线 Cables	X	0	0	0	0	0
管路及橡胶 Tubing & Rubber	0	0	0	0	0	0
塑料部件 Plastic	0	0	0	0	0	0
连接部件 Hardware	0	0	0	0	0	0
包装材料 Packing Material	0	0	0	0	0	0

0: 表示该有毒有害物质在该部件所有均质材料中的含量均在SJ/T 11363-2006标准规定的限量要求以下

x: 表示该有毒有害物质至少在该部件的某一均质材料中的含量超出SJ/T 11363-2006标准规定的限量要求

(企业可在此处, 根据实际情况对上表中打“x”的技术原因进行进一步说明)

0: Indicates that the toxic or hazardous substances contained in all of the homogenous materials for this part is below the limit requirements in SJ/T 11363-2006.

X: Indicates that this toxic or hazardous substance contained in at least one of the homogenous materials used for this part in above the limit requirement in SJ/T11363-2006.

Abbreviations

The following list is a composite of the symbols, abbreviations, acronyms, and reference designators either used in this manual or related to the information in it. When the same abbreviation (or reference designator) is used for more than one word (or type of component), all meanings relevant to this manual are included, separated by semicolons.

' — foot	CDRH — Center for Devices and Radiological Health
“ — inch	CFSE — carboxyfluorescein succinimidyl ester
% — percent	cm — centimeters
°C — degrees Celsius	CSV — comma separated value
°F — degrees fahrenheit	CV — coefficient of variation
± — plus or minus	DNA — deoxyribonucleic acid
< — less than	ECD — Energy Coupled Dye
> — greater than	EFUP — Environmentally friendly Use Period
≤ — less than or equal to	EMF — enhanced metafile format
μ — micron	EMR — electromagnetic radiation
μL — microliters	FAPD — Fiber Array Photo Detector
μm — micrometer	FCS — flow cytometry standard
A — ampere	FITC — Fluorescein isothiocyanate
AC — alternating current	FSC — forward scatter
APC — Allophycocyanin	GB — gigabyte
APC-A700 — Allophycocyanin-Alexa Fluor™ 700 tandem dye	GHz — gigahertz
APC-A7500 — Allophycocyanin-Alexa Fluor™ 750	Gr Wt — gross weight
APC-Cy7 — Allophycocyanin-Cyanin 7	H — humidity
Acq. — Acquisition	Hz — hertz
BCI — Beckman Coulter Incorporated	IEC — International Electrotechnical Commission
BMP — bitmap	kg — kilograms
BP — band-pass filter	KO — Krome Orange
	LED — light emitting diode

L — liter	RoHS — Restriction of Hazardous Substances Directive
LJ — Levey Jennings	RPTM — real-time messaging protocol
LWH — length, width, height	S/N — serial number
m — meter	SNR — signal to noise ratio
MB — megabyte	SSC — side scatter
MFI — median fluorescence intensity	USB — universal serial bus
Mhz — megahertz	USPTO — United States Patent and Trademark Office
min — minute	V — volts
mL — milliliter	VA — volt-ampere
mm — millimeter	VAC — voltage alternating current
mW — milliwatt	VSSC — violet side scatter
NA — numerical aperture	WDM — wavelength division multiplexer
NaClO — sodium hypochlorite solution	W — watts
NaN₃ — sodium azide	
nm — nanometer	
Nt Wt — net weight	
PB — Pacific Blue™ dye	
PC5 — Phycoerythrin-Cy™5 tandem dye	
PC5.5 — Phycoerythrin-Cy™5.5 tandem dye	
PC7 — Phycoerythrin-Cy™7 tandem dye	
PE — Phycoerythrin	
PEEK — polyether ether ketone	
PerCP — Peridinin-Chlorophyll	
PI — Propidium Iodide	
PN — part number	
QC — quality control	
RAM — random access memory	
rCV — robust coefficient of variation	
RH — relative humidity	

Symbols

- ,
- " define, [Abbreviations-1](#)
- " define, [Abbreviations-1](#)
- °C define, [Abbreviations-1](#)
- °F define, [Abbreviations-1](#)
- μ define, [Abbreviations-1](#)
- μL define, [Abbreviations-1](#)
- μm define, [Abbreviations-1](#)
- ± define, [Abbreviations-1](#)
- < define, [Abbreviations-1](#)
- > define, [Abbreviations-1](#)

A

- A define, [Abbreviations-1](#)
- AC define, [Abbreviations-1](#)
- acoustic noise level, [1-20](#)
- Acq. define, [Abbreviations-1](#)
- acquisition screen, [2-3](#)
 - collection, [2-5](#)
 - navigation, [2-4](#)
 - plot area, [2-8](#)
 - status bar, [2-9](#)
 - test tubes, [2-7](#)
- acquisition settings
 - to configure, [5-25](#)
- adding
 - Deep Clean solution, [11-10](#)
- adding channels
 - for compensation, [6-21](#)

- adjust compensation
 - manually, [6-15](#)
- adjusting
 - compensation, [6-15](#)
 - compensation settings, [7-7](#)
 - gain, [5-36](#)
 - threshold, [5-37](#)
- adjustment
 - nonscheduled, [11-49](#)
 - routine, [11-2](#)
- advanced menu, [2-17](#)
- alarm
 - Fluidics module, [1-9](#)
 - mute, [1-9](#)
- alarm does not sound when the waste container is full or the sheath fluid container is low and the software status display is red, [9-8](#)
- analysis
 - screen, [7-1](#)
- analysis screen, [2-9](#)
 - to open, [7-3](#)
- analyzing
 - data, [5-44](#)
- APC
 - define, [Abbreviations-1](#)
- APC-A7500
 - define, [Abbreviations-1](#)
- APC-Cy7
 - define, [Abbreviations-1](#)
- autosampling system
 - Deep Clean solution peristaltic pump, [1-9](#)

B

- backflush settings
 - to change, [11-64](#)
- backup
 - manual injection mode, [3-7](#)
- band-pass filter, [1-5](#), [Abbreviations-1](#)
- band-pass filters, [1-5](#)
- BCI
 - define, [Abbreviations-1](#)
- BMP

- define, [Abbreviations-1](#)
- bottle
 - Deep Clean solution, [1-9](#)
- BP
 - define, [Abbreviations-1](#)
- C**
- calculating
 - compensation values, [6-8](#), [6-13](#)
 - concentration, [7-6](#)
 - sample injection volume, [7-6](#)
- calculation of the automatic compensation
 - experiment is incorrect, [9-14](#)
- calculations
 - compensation, [6-1](#)
- calibrating
 - plate position [with plate loader], [11-66](#)
 - sample flow rate, [11-49](#)
 - sample flow rate with plate loader, [11-52](#)
- caution label
 - RoHS, [9-7](#)
- CDRH
 - define, [Abbreviations-1](#)
- CFSE
 - define, [Abbreviations-1](#)
- changing
 - mixer and backflush settings, [11-64](#)
 - tube name, [5-25](#)
- changing sample probe
 - from plate loader to single tube sample station, [11-32](#)
 - from single tube sample station to plate loader, [11-27](#)
- channel
 - to set, [5-25](#)
- channels
 - adding for compensation, [6-21](#)
 - fluorescence, [5-15](#)
 - to set, [5-25](#)
- characteristics
 - performance, [1-22](#)
- check
 - waste and reagent levels, [3-2](#)
- cleaning
 - nonscheduled, [10-12](#)
 - routine, [10-1](#)
 - sample probe, [10-6](#)
 - sample station, [10-5](#)
 - sheath fluid container, [10-9](#)
 - waste container, [10-10](#)
- cleaning and ventilation
 - installation environment validation, [A-2](#)
- cleaning solution
 - to prepare, [8-1](#)
- cleaning the sample station
 - routine maintenance, [10-5](#)
- cleaning the sheath fluid container
 - routine maintenance, [10-9](#)
- cleaning the waste container
 - routine maintenance, [10-10](#)
- cm
 - define, [Abbreviations-1](#)
- collecting
 - data, [5-21](#)
 - QC data, [4-8](#)
 - QC data with plate loader, [4-10](#)
- collection
 - acquisition screen, [2-5](#)
- collection conditions
 - to set, [5-39](#)
- compensation
 - adding channels, [6-21](#)
 - calculations, [6-1](#)
 - to adjust, [6-15](#)
 - to manually adjust, [6-15](#)
- compensation controls
 - compensation experiment screen, [2-11](#)
- compensation experiment
 - to create, [6-2](#)
- compensation experiment screen, [2-10](#)
 - compensation controls, [2-11](#)
- compensation experiment with plate loader
 - creating, [6-10](#)
- compensation library
 - to manage, [6-20](#)
- compensation matrix
 - to create from previously acquired data, [6-14](#)
 - to generate, [6-4](#), [6-13](#)
- compensation sample
 - prepare, [6-4](#), [6-12](#)
- compensation settings
 - adjust, [7-7](#)
 - exporting, [6-18](#)
 - importing and exporting, [5-54](#)
- compensation settings from compensation library
 - to import, [6-17](#)

- compensation settings from compensation matrix files
 - to import, 6-16
 - compensation values
 - to calculate, 6-8, 6-13
 - components
 - Cytometer, 1-2
 - Fluid Containers, 1-2
 - fluidics system, 1-7
 - instrument, 1-1
 - main, 1-1
 - optical, 1-2
 - plate holder, 1-15
 - plate loader, 1-13
 - Workstation, 1-2
 - concentration
 - calculation, 7-6
 - sample injection volume, 7-6
 - concentration calculation is incorrect, 9-15
 - concluding
 - experiment, 5-57
 - configuration
 - system, 1-17
 - configuring
 - acquisition settings, 5-25
 - confirming results, 4-14
 - connection indicator light in the lower left corner of the software screen is red and displays Disconnected and Error, 9-8
 - conventions used, -xxii
 - copying
 - experiments, 7-1
 - previously acquired experiment, 7-1
 - create a compensation experiment
 - start page operations, 2-2
 - create a new experiment from a template
 - start page operations, 2-2
 - create a new screen
 - start page operations, 2-2
 - creating
 - compensation experiment, 6-2
 - compensation experiment with plate loader, 6-10
 - compensation matrix from previously acquired data, 6-14
 - detector configuration, 5-13
 - dot plot overlays, 7-5
 - Levy Jennings charts, 4-17
 - multi-data histograms, 7-5
 - new experiment, 5-1
 - new experiment with plate loader, 5-3
 - plots and gates, 5-27
 - CSV
 - define, Abbreviations-1
 - custom statistics
 - setting, 5-41
 - customer-replaceable parts
 - ordering, B-1
 - customized parameters
 - setting, 5-40
 - CV
 - define, Abbreviations-1
 - Cytometer, 1-2, A-6
 - Cytometer cannot be turned on, 9-8
 - cytometer menu, 2-16
- ## D
- daily shutdown
 - routine maintenance, 10-1
 - daily shutdown with plate loader
 - routine maintenance, 10-4
 - daily start up
 - routine maintenance, 10-1
 - daily start up with plate loader
 - routine maintenance, 10-4
 - data
 - analyzing, 5-44
 - collecting, 5-21
 - exporting, 5-44
 - sampling, 5-21
 - to import, 7-1
 - data populations are normal on one laser, but too low on another laser, 9-12
 - data populations are not where they are expected, 9-13
 - data sheets, material safety
 - how to order, 1-19
 - Deep Clean
 - procedure, 10-7
 - routine maintenance, 10-7
 - Deep Clean solution
 - to add, 11-10
 - to prepare, 11-10
 - Deep Clean solution bottle
 - fluidics module, 1-9
 - Deep Clean solution peristaltic pump
 - autosampling system, 1-9
 - default
 - detector configuration, 5-14

- define
 - %, [Abbreviations-1](#)
 - quality control (QC), [4-1](#)
 - symbols, [-ix](#)
 - defining the negative population, [6-4](#)
 - detector (WDM)
 - optical components, [1-2](#)
 - detector configuration
 - to create, [5-13](#)
 - to edit, [5-13](#)
 - to select, [5-13](#)
 - to verify, [5-13](#)
 - detector configuration default, [5-14](#)
 - detector unit
 - wavelength division multiplexor (WDM), [1-3](#)
 - dimensions
 - instrument, [1-20](#)
 - disposal
 - precaution, [9-7](#)
 - waste, [A-4](#)
 - DNA
 - define, [Abbreviations-1](#)
 - dot plot overlays
 - to create, [7-5](#)
 - dual-parameter plots, [2-18](#)
- E**
- ECD
 - define, [Abbreviations-1](#)
 - editing
 - detector configuration, [5-13](#)
 - EFUP
 - define, [Abbreviations-1](#)
 - electronic devices
 - fuse, [1-18](#)
 - load button, [1-18](#)
 - power switch, [1-18](#)
 - EMF
 - define, [Abbreviations-1](#)
 - EMR
 - define, [Abbreviations-1](#)
 - environment validation
 - installation, [A-1](#)
 - environment validation (installation)
 - power source, [A-3](#)
 - temperature and humidity, [A-4](#)
 - ventilation and cleaning, [A-2](#)
 - worktable, [A-2](#)
 - environmental label
 - RoHS, [9-7](#)
 - exit the software
 - start page operations, [2-2](#)
 - experiment
 - concluding, [5-57](#)
 - experiment (new)
 - creating, [5-1](#)
 - experiment saving, [5-56](#)
 - experiment selection
 - start page, [3-22](#)
 - experiment settings, [2-20](#)
 - experiments
 - to copy, [7-1](#)
 - exporting
 - compensation settings, [5-54](#), [6-18](#)
 - data, [5-44](#)
 - FCS files, [5-49](#)
 - instrument settings, [5-53](#), [5-54](#)
 - plots of multiple tubes as picture files, [5-52](#)
 - results, [7-7](#)
 - statistics table of multiple tubes as a picture file, [5-52](#)
- F**
- FAPD
 - define, [Abbreviations-1](#)
 - FCS
 - define, [Abbreviations-1](#)
 - FCS files
 - exporting, [5-49](#)
 - files menu, [2-16](#)
 - filling sheath fluid container, [3-2](#)
 - filter
 - optical, [1-3](#)
 - sheath fluid, [1-9](#)
 - FITC
 - define, [Abbreviations-1](#)
 - flow cell
 - to prime, [11-36](#)
 - flow cell waste out
 - fluidic connection, [1-10](#), [3-3](#)
 - Fluid Container holder, [1-8](#)
 - Fluid Containers, [1-2](#), [A-6](#)
 - component, [1-2](#)
 - fluidics system, [1-8](#)
 - fluidics system component, [1-7](#)
 - fluid sensor holder cutout, [1-8](#)
 - fluid status information displays red for Sheath and/or Waste even though the sheath

- fluid container is full and the waste container is empty, [9-9](#)
 - fluidic connections
 - flow cell waste out, [1-10, 3-3](#)
 - sheath fluid in, [1-10, 3-3](#)
 - sheath fluid level sensor connector, [1-10, 3-3](#)
 - sheath return, [1-10, 3-3](#)
 - waste level sensor connector, [1-10, 3-3](#)
 - waste out, [1-10, 3-3](#)
 - Fluidics module
 - alarm, [1-9](#)
 - fluidics module
 - Deep Clean solution bottle, [1-9](#)
 - fluidics system, [1-9](#)
 - fluidics system component, [1-7](#)
 - sheath fluid filters, [1-9](#)
 - fluidics system
 - components, [1-7](#)
 - Fluid Containers, [1-8](#)
 - fluidics module, [1-9](#)
 - fluidics system components
 - Fluid Containers, [1-7](#)
 - fluidics module, [1-7](#)
 - fluorescence channels, [5-15](#)
 - four-quadrant gates
 - for dual-parameter plots, [2-19](#)
 - front cover
 - removal, [11-2](#)
 - FSC
 - define, [Abbreviations-1](#)
 - functions
 - software, [2-1](#)
 - fuse
 - electronic devices, [1-18](#)
 - to replace, [11-60](#)
- G**
- gain
 - to adjust, [5-36](#)
 - gate settings, [2-22](#)
 - gates
 - to create, [5-27](#)
 - gates for dual-parameter plots
 - four-quadrant gates, [2-19](#)
 - lasso gates, [2-19](#)
 - polygon gates, [2-19](#)
 - rectangle gates, [2-19](#)
 - gates for single-parameter plots
 - line-segment gates, [2-19](#)
 - vertical gates, [2-19](#)
 - GB
 - define, [Abbreviations-1](#)
 - generating
 - compensation matrix, [6-4, 6-13](#)
 - Ghz
 - define, [Abbreviations-1](#)
 - Gr. Wt.
 - define, [Abbreviations-1](#)
 - graphic and gating styles, [2-18](#)
 - graphics
 - printing, [5-54](#)
- H**
- H
 - define, [Abbreviations-1](#)
 - hazard
 - laser, [9-1](#)
 - hazards
 - laser beam, [9-2](#)
 - radiation, [9-2](#)
 - hazards/precautions, [9-1](#)
 - help menu, [2-17](#)
 - humidity and temperature
 - installation environment validation, [A-4](#)
 - Hz
 - define, [Abbreviations-1](#)
- I**
- IEC
 - define, [Abbreviations-1](#)
 - importing
 - compensation settings, [5-54](#)
 - compensation settings from compensation library, [6-17](#)
 - compensation settings from compensation matrix files, [6-16](#)
 - data, [7-1](#)
 - instrument settings, [5-53](#)
 - lot-specific target values, [4-4](#)
 - previously acquired data, [7-1](#)
 - information
 - ordering, [1-19](#)
 - initializing the instrument, [3-23](#)
 - inspecting materials
 - unpacking, [A-4](#)
 - inspection
 - liquid flow tubing, [11-35](#)

- pre-boot, 3-1
- inspection when unpacking, A-4
- installation
 - environment validation, A-1
 - instrument, A-1
 - software, A-11
- installation category, 1-20
- installing
 - instrument configuration file, A-21
 - Plate Loader module, 11-39
 - software, A-12
- installing the instrument and connecting the equipment
 - unpacking inspection, A-5
- instrument
 - components, 1-1
 - initializing, 3-23
 - inspecting materials, A-4
 - installation, A-1
 - maintenance, 11-1
 - parameters, 1-20
 - shut off, 8-1
 - transportation and storage, A-1
 - unpacking, A-4
- instrument characteristics, 1-20
- instrument components
 - Cytometer, 1-2
 - Fluid Containers, 1-2
 - Workstation, 1-2
- instrument configuration
 - unpacking inspection, A-4
- instrument configuration file
 - to install, A-21
- instrument dimensions, 1-20
- instrument operations cannot be performed in the Acquisition screen, 9-16
- instrument settings
 - exporting, 5-54
 - importing, 5-53
 - importing and exporting, 5-53
- instrument specifications, 1-20
- instrument transport or storage
 - to prepare, 10-12

K

- kg
 - define, Abbreviations-1
- KO
 - define, Abbreviations-1

L

- L
 - define, Abbreviations-2
- label
 - RoHS caution, 9-7
 - RoHS environmental, 9-7
- labels
 - disposal of electrical instrumentation, warning, 9-6
 - RoHS caution, 9-7
 - RoHS environmental, 9-7
 - to set, 5-25
- language settings, 2-23
- laser
 - hazards, 9-1
- laser beam
 - hazards, 9-2
- laser delay
 - to set, 11-56
- laser delay values are out of range, 9-11
- laser lines, 1-20
- laser power is low, 9-10
- laser wavelength, 1-20
- lasso gates
 - for dual-parameter plots, 2-19
- launching the software, 2-1
- LED
 - define, Abbreviations-1
- Levey Jennings charts
 - to create, 4-17
- line segment gates
 - for single-parameter plots, 2-19
- liquid flow tubing
 - inspection, 11-35
- liquid flow tubing inspection
 - routine maintenance, 11-35
- LJ
 - define, Abbreviations-2
- load button
 - electronic devices, 1-18
- lot-specific target values
 - to import, 4-4
- LWH
 - define, Abbreviations-2

M

- m
 - define, Abbreviations-2

- main components, [1-1](#)
 - maintenance
 - instrument, [11-1](#)
 - See also* routine maintenance; nonscheduled maintenance
 - maintenance reminder
 - to manage, [11-7](#)
 - managing
 - compensation library, [6-20](#)
 - maintenance reminder, [11-7](#)
 - manual
 - adjust compensation, [6-15](#)
 - manual injection mode
 - running small sample volumes, [3-7](#)
 - material safety data sheets (MSDS/SDS)
 - how to order, [1-19](#)
 - MB
 - define, [Abbreviations-2](#)
 - menu
 - acquisition and analysis screen, [2-15](#)
 - advanced, [2-17](#)
 - cytometer, [2-16](#)
 - files, [2-16](#)
 - help, [2-17](#)
 - QC, [2-17](#)
 - setting, [2-17](#)
 - software, [2-14](#)
 - menu tree
 - software, [2-14](#)
 - MFI
 - define, [Abbreviations-2](#)
 - Mhz
 - define, [Abbreviations-2](#)
 - min
 - define, [Abbreviations-2](#)
 - mixer is not functioning, [9-16](#)
 - mixer settings
 - to change, [11-64](#)
 - mL
 - define, [Abbreviations-2](#)
 - mm
 - define, [Abbreviations-2](#)
 - modifying
 - well settings with plate loader, [5-9](#)
 - modifying well settings, [5-9](#)
 - applying existing well settings to additional wells, [5-10](#)
 - moving well location [with plate loader], [5-11](#)
 - moving
 - well location [with plate loader], [5-11](#)
 - MSDS (material safety data sheets)
 - how to order, [1-19](#)
 - multi-data histograms
 - to create, [7-5](#)
 - multiple tube plots
 - export as picture files, [5-52](#)
 - multiple tube statistics table
 - export as picture files, [5-52](#)
 - mute
 - alarm, [1-9](#)
 - mute alerter icon, [1-9](#)
 - mW
 - define, [Abbreviations-2](#)
- ## N
- NA
 - define, [Abbreviations-2](#)
 - NaClO
 - define, [Abbreviations-2](#)
 - NaN3
 - define, [Abbreviations-2](#)
 - navigation
 - acquisition screen, [2-4](#)
 - QC screen, [2-13](#)
 - negative population
 - to define using unstained samples, [6-4](#)
 - new experiment
 - creating, [5-1](#)
 - new experiment with plate loader
 - creating, [5-3](#)
 - nm
 - define, [Abbreviations-2](#)
 - no changes occurred after manually adjusting compensation settings, [9-13](#)
 - no data acquisition, [9-12](#)
 - nonscheduled cleaning, [10-12](#)
 - nonscheduled maintenance
 - adding the Deep Clean solution, [11-10](#)
 - calibrating the sample flow rate, [11-49](#)
 - calibrating the sample flow rate with plate loader, [11-52](#)
 - cleaning the sample probe, [10-6](#)
 - preparing the instrument for storage or transport, [10-12](#)
 - replacing the fuse, [11-60](#)
 - replacing the optical filter, [11-57](#)
 - nonscheduled replacement/adjustment, [11-49](#)

- Nt. Wt.
 - define, [Abbreviations-2](#)
- O**
- open a compensation experiment
 - start page operations, [2-2](#)
- open an experiment
 - start page operations, [2-2](#)
- open software, [3-4](#)
- opening
 - analysis screen, [7-3](#)
- optical
 - components, [1-2](#)
- optical bench
 - optical component, [1-2](#)
- optical components
 - detector (WDM), [1-2](#)
 - optical bench, [1-2](#)
 - optical fiber, [1-2](#)
- optical fiber, [1-6](#)
- optical filter, [1-3](#)
 - to replace, [11-57](#)
- ordering
 - customer-replaceable parts, [B-1](#)
- ordering information, [1-19](#)
- overlay dot plots, [2-18](#)
- overlay histograms, [2-18](#)
- P**
- page setup settings, [2-22](#)
- parameters
 - instrument, [1-20](#)
- PB
 - define, [Abbreviations-2](#)
- PC5
 - define, [Abbreviations-2](#)
- PC5.5
 - define, [Abbreviations-2](#)
- PC7
 - define, [Abbreviations-2](#)
- PE
 - define, [Abbreviations-2](#)
- PEEK
 - define, [Abbreviations-2](#)
- PerCP
 - define, [Abbreviations-2](#)
- performance characteristics, [1-22](#)
- performing
 - daily quality control, [4-1](#)
- PI
 - define, [Abbreviations-2](#)
- picture files
 - to export, [5-52](#)
- plate holder
 - components, [1-15](#)
- plate holder with plate loader
 - replacing, [11-38](#)
- plate loader
 - components, [1-13](#)
- Plate Loader module
 - installing, [11-39](#)
 - removing, [11-39](#)
- plate loader PEEK tubing
 - replacing, [11-21](#)
- plate loader PEEK tubing (replacing)
 - routine maintenance, [11-21](#)
- plate position [with plate loader]
 - calibrating, [11-66](#)
- plot area
 - acquisition screen, [2-8](#)
- plot settings, [2-21](#)
- plots
 - dual-parameter, [2-18](#)
 - overlay dot plots, [2-18](#)
 - overlay histograms, [2-18](#)
 - single-parameter, [2-18](#)
 - to create, [5-27](#)
 - to set, [7-3](#)
- PN
 - define, [Abbreviations-2](#)
- pollution degree, [1-20](#)
- polygon gtaes
 - for dual-parameter plots, [2-19](#)
- population amplitude is decreasing and CV
 - values are increasing, [9-11](#)
- populations are drifting, [9-11](#)
- position
 - sample tube holder, [1-11](#)
- power source
 - installation environment validation, [A-3](#)
- power source inspection
 - pre-boot, [3-4](#)
- power switch
 - electronic devices, [1-18](#)
- pre-boot inspection, [3-1](#)
 - check waste and reagent levels, [3-2](#)
 - power source inspection, [3-4](#)

- workstation connections inspection, [3-4](#)
- precaution
 - disposal, [9-7](#)
- precautions
 - safety, [-viii](#)
- precautions/hazards, [9-1](#)
- preparation process
 - QC sample, [4-2](#)
 - QC sample with plate loader, [4-3](#)
- preparing
 - compensation sample, [6-4](#), [6-12](#)
 - Deep Clean solution, [11-10](#)
 - instrument for storage or transport, [10-12](#)
 - QC sample, [4-2](#)
 - QC sample with plate loader, [4-3](#)
 - the cleaning solution, [8-1](#)
- preparing QC sample
 - required materials, [4-2](#)
- preparing QC sample with plate loader
 - required materials, [4-3](#)
- previously acquired data
 - to import, [7-1](#)
- previously acquired experiment
 - to copy, [7-1](#)
- priming
 - flow cell, [11-36](#)
- printing
 - graphics, [5-54](#)
- procedure
 - Deep Clean, [10-7](#)
- product description, [1-1](#)

Q

- QC
 - define, [Abbreviations-2](#)
 - result manager, [4-20](#)
- QC aborted due to low event rate, [9-17](#)
- QC data
 - collecting, [4-8](#)
- QC data with plate loader
 - collecting, [4-10](#)
- QC experiment screen, [2-11](#), [2-12](#)
- QC failed, [9-18](#)
- QC menu, [2-17](#)
- QC menu tree
 - software, [2-15](#)
- QC sample
 - preparation, [4-2](#)
 - preparation process, [4-2](#)

- QC sample with plate loader
 - preparation, [4-3](#)
 - preparation process, [4-3](#)
- QC screen
 - navigation, [2-13](#)
- QC settings screen, [2-11](#)
- QC software menu tree, [2-15](#)
- quality control
 - perform daily, [4-1](#)
- quality control (QC)
 - define, [4-1](#)

R

- radiation
 - hazards, [9-2](#)
- RAM
 - define, [Abbreviations-2](#)
- rCV
 - define, [Abbreviations-2](#)
- reagent levels
 - check, [3-2](#)
- rectangle gates
 - for dual-parameter plots, [2-19](#)
- reinstallation procedures
 - right-side cover, [11-4](#)
- removal procedures
 - front cover, [11-2](#)
 - right-side cover, [11-4](#)
- removing
 - Plate Loader module, [11-39](#)
- replacement
 - nonscheduled, [11-49](#)
 - routine, [11-2](#)
- replacing
 - fuse, [11-60](#)
 - optical filter, [11-57](#)
 - plate holder with plate loader, [11-38](#)
 - plate loader PEEK tubing, [11-21](#)
 - sample peristaltic pump tubing for sample
 - loading, [11-16](#)
 - sheath fluid filter, [11-12](#)
 - sheath fluid harness and/or waste
 - harness, [11-62](#)
- replacing the peristaltic pump for sample
 - loading
 - routine maintenance, [11-16](#)
- replacing the sample probe for plate loader
 - routine maintenance, [11-21](#)
- replacing the sheath fluid filter

- routine maintenance, [11-12](#)
- required materials
 - QC sample preparation, [4-2](#)
 - QC sample preparation with plate loader, [4-3](#)
 - software installation, [A-12](#)
- result manager
 - QC, [4-20](#)
- results
 - confirming, [4-14](#)
 - to export, [7-7](#)
- RH
 - define, [Abbreviations-2](#)
- right-side cover
 - reinstallation, [11-4](#)
 - removal, [11-4](#)
- RoHS
 - caution label, [9-7](#)
 - define, [Abbreviations-2](#)
 - environmental label, [9-7](#)
- routine cleaning, [10-1](#)
- routine maintenance
 - cleaning the sample station, [10-5](#)
 - cleaning the sheath fluid container, [10-9](#)
 - cleaning the waste container, [10-10](#)
 - daily startup and shutdown, [10-1](#)
 - daily startup and shutdown with plate loader, [10-4](#)
 - Deep Clean, [10-7](#)
 - liquid flow tubing inspection, [11-35](#)
 - replacing the plate loader PEEK tubing, [11-21](#)
 - replacing the sample peristaltic pump tubing for sample loading, [11-16](#)
 - replacing the sheath fluid filter, [11-12](#)
- routine replacement/adjustment, [11-2](#)
- RPTM
 - define, [Abbreviations-2](#)
- running
 - single positive control samples, [6-6](#)
 - system startup program, [3-12](#)
 - system startup program with plate loader, [3-15](#)
- running small sample volumes
 - manual injection mode, [3-7](#)
- precautions, [-viii](#)
- sample
 - checks before running, [5-13](#)
- sample acquisition position
 - sample tube holder position, [1-11](#)
- sample flow rate
 - calibrating, [11-49](#)
- sample flow rate is unstable, [9-10](#)
- sample flow rate with plate loader
 - calibrating, [11-52](#)
- sample injection mode
 - selecting, [3-6](#)
- sample is flowing, but no signal appears in the plot, [9-14](#)
- sample loading
 - backup, [3-7](#)
- sample loading position
 - sample tube holder position, [1-11](#)
- sample peristaltic pump tubing
 - to replace, [11-16](#)
- sample peristaltic pump tubing for sample loading
 - to replace, [11-16](#)
- sample peristaltic pump tubing for sample loading (replacing)
 - routine maintenance, [11-16](#)
- sample probe, [1-11](#)
 - sample station, [1-11](#)
 - to clean, [10-6](#)
- sample probe change
 - from plate loader to single tube sample station, [11-32](#)
 - from single tube sample station to plate loader, [11-27](#)
- sample probe for plate loader
 - replacing, [11-21](#)
- sample probe is too low, [9-15](#)
- sample station, [1-11](#)
 - sample probe, [1-11](#)
 - sample tube holder, [1-11](#)
 - to clean, [10-5](#)
 - washer station and mixxer, [1-11](#)
- sample station (cleaning)
 - routine maintenance, [10-5](#)
- sample tube holder
 - sample station, [1-11](#)
- sample tube holder cannot move up and down automatically, [9-9](#)
- sample tube holder position

- sample acquisition position, [1-11](#)
- sample loading position, [1-11](#)
- standby position, [1-11](#)
- sample wells with plate loader
 - setting, [5-5](#)
- sampling
 - data, [5-21](#)
- sampling flow rate is too fast, [9-10](#)
- saving
 - experiment, [5-56](#)
- screen
 - acquisition, [2-3](#)
 - analysis, [2-9](#), [7-1](#), [7-3](#)
 - compensation experiment, [2-10](#)
 - QC experiment, [2-11](#), [2-12](#)
 - QC settings, [2-11](#)
 - software, [2-1](#)
- SDS (safety data sheets)
 - how to order, [1-19](#)
- selecting
 - detector configuration, [5-13](#)
 - proper sample injection mode, [3-6](#)
- setting
 - channel, [5-25](#)
 - channels, [5-25](#)
 - collection conditions, [5-39](#)
 - custom statistics, [5-41](#)
 - customized parameters, [5-40](#)
 - labels, [5-25](#)
 - laser delay, [11-56](#)
 - sample wells with sample wells, [5-5](#)
 - the plots and statistics, [7-3](#)
- setting menu, [2-17](#)
- setting up
 - violet side scatter channel (VSSC), [5-18](#)
- settings
 - acquisition, [5-25](#)
 - experiment, [2-20](#)
 - gate, [2-22](#)
 - language, [2-23](#)
 - page setup, [2-22](#)
 - plot, [2-21](#)
 - software, [2-20](#)
 - tube, [2-21](#)
- sheath fluid container, [1-8](#)
 - to clean, [10-9](#)
 - to fill, [3-2](#)
- sheath fluid container (cleaning)
 - routine maintenance, [10-9](#)
- sheath fluid filter
 - to replace, [11-12](#)
- sheath fluid filter (replacing)
 - routine maintenance, [11-12](#)
- sheath fluid filters
 - fluidics module, [1-9](#)
- sheath fluid harness and sensor, [1-8](#)
- sheath fluid in
 - fluidic connection, [1-10](#), [3-3](#)
- sheath fluid level sensor connector
 - fluidic connection, [1-10](#), [3-3](#)
- sheath return
 - fluidic connection, [1-10](#), [3-3](#)
- shut off
 - the instrument, [8-1](#)
- shutdown daily
 - routine maintenance, [10-1](#)
- shutdown daily with plate loader
 - routine maintenance, [10-4](#)
- single positive control samples
 - to run, [6-6](#)
- single-parameter plots, [2-18](#)
- SNR
 - define, [Abbreviations-2](#)
- software
 - functions, [2-1](#)
 - launching, [2-1](#)
 - main screen, [2-1](#)
 - open, [3-4](#)
 - to install, [A-12](#)
 - to start, [A-23](#)
- software installation, [A-11](#)
 - installing CytExpert software, [A-12](#)
 - installing instrument configuration file, [A-21](#)
 - required materials, [A-12](#)
 - starting the software, [A-23](#)
- software installation fails, [9-16](#)
- software menu, [2-14](#)
 - acquisition and analysis screen menu, [2-15](#)
- software menu tree, [2-14](#)
- software operations
 - create a new experiment, [2-2](#)
- software screen, [2-1](#)
 - start page, [2-2](#)
 - start page operations, [2-2](#)
- software settings, [2-20](#)
- specifications
 - characteristics, [1-20](#)
 - instrument, [1-20](#)
- SSC

- define, [Abbreviations-2](#)
 - standby position
 - sample tube holder position, [1-11](#)
 - start page
 - main software screen, [2-2](#)
 - selecting experiments, [3-22](#)
 - start page operations
 - create a compensation experiment, [2-2](#)
 - create a new experiment from a template, [2-2](#)
 - exit the software, [2-2](#)
 - main software screen, [2-2](#)
 - open a compensation experiment, [2-2](#)
 - open an experiment, [2-2](#)
 - starting
 - the software, [A-23](#)
 - startup daily
 - routine maintenance, [10-1](#)
 - startup daily with plate loader
 - routine maintenance, [10-4](#)
 - station
 - sample, [1-11](#)
 - statistics
 - to set, [7-3](#)
 - status bar
 - acquisition screen, [2-9](#)
 - storing the instrument, [A-1](#)
 - symbols
 - define, [-ix](#)
 - system configuration, [1-17](#)
 - system startup program
 - to run, [3-12](#)
 - system startup program with plate loader running, [3-15](#)
- T**
- table
 - troubleshooting, [9-8](#)
 - temperature and humidity
 - installation environment validation, [A-4](#)
 - test tubes
 - acquisition screen, [2-7](#)
 - threshold
 - to adjust, [5-37](#)
 - transporting the instrument, [A-1](#)
 - troubleshooting, [9-1](#)
 - alarm does not sound when the waste container is full or the sheath fluid container is low and the software status display is red, [9-8](#)
 - calculation of the automatic compensation experiment is incorrect, [9-14](#)
 - concentration calculation is incorrect, [9-15](#)
 - connection indicator light in the lower left corner of the software screen is red and displays Disconnected and Error, [9-8](#)
 - Cytometer cannot be turned on, [9-8](#)
 - data populations are normal on one laser, but too low on another laser, [9-12](#)
 - data populations are not where they are expected, [9-13](#)
 - fluid status information displays red for Sheath and/or Waste even though the sheath fluid container is full and the waste container is empty, [9-9](#)
 - instrument operations cannot be performed in the Acquisition screen, [9-16](#)
 - laser delay values are out of range, [9-11](#)
 - laser power is low, [9-10](#)
 - mixer is not functioning, [9-16](#)
 - no changes occurred after manually adjusting compensation settings, [9-13](#)
 - no data acquisition, [9-12](#)
 - population amplitude is decreasing and CV values are increasing, [9-11](#)
 - populations are drifting, [9-11](#)
 - QC aborted due to low event rate, [9-17](#)
 - QC failed, [9-18](#)
 - sample flow rate is unstable, [9-10](#)
 - sample is flowing, but no signal appears in the plot, [9-14](#)
 - sample probe is too low, [9-15](#)
 - sample tube holder cannot move up and down automatically, [9-9](#)
 - sampling flow rate is too fast, [9-10](#)
 - software installation fails, [9-16](#)
 - table, [9-8](#)
 - wash station drips during backflush, [9-16](#)
 - Workstation cannot be turned on, [9-8](#)
 - tube
 - settings, [2-21](#)
 - tube name
 - to change, [5-25](#)
 - turning the power on, [3-4](#)
- U**
- unpacking inspection, [A-4](#)
 - check instrument configuration, [A-4](#)

- installing the instrument and connecting the equipment, [A-5](#)
- unpacking the instrument, [A-4](#)
- unstained samples
 - to define the negative population, [6-4](#)
- USB
 - define, [Abbreviations-2](#)
- using unstained samples, [6-4](#)
- USPTO
 - define, [Abbreviations-2](#)

V

- V
 - define, [Abbreviations-2](#)
- VA
 - define, [Abbreviations-2](#)
- VAC
 - define, [Abbreviations-2](#)
- ventilation and cleaning
 - installation environment validation, [A-2](#)
- verifying
 - detector configuration, [5-13](#)
- vertical gates
 - for single-parameter plots, [2-19](#)
- violet side scatter channel (VSSC)
 - to set up, [5-18](#)
- VSSC
 - define, [Abbreviations-2](#)

W

- W
 - define, [Abbreviations-2](#)
- wash station and mixer
 - sample station, [1-11](#)
- wash station drips during backflush, [9-16](#)
- waste container, [1-8](#)
 - to clean, [10-10](#)
- waste container (cleaning)
 - routine maintenance, [10-10](#)
- waste disposal, [A-4](#)
- waste fluid harness and sensor, [1-8](#)
- waste harness
 - to replace, [11-62](#)
- waste level sensor connector
 - fluidic connection, [1-10, 3-3](#)
- waste levels
 - check, [3-2](#)
- waste out

- fluidic connection, [1-10, 3-3](#)
- wavelength
 - laser, [1-20](#)
- wavelength division multiplexer (WDM), [1-3](#)
- WDM
 - define, [Abbreviations-2](#)
- well settings with plate loader
 - modifying, [5-9](#)
- copying
 - wells, [5-10](#)
- cutting
 - wells, [5-10](#)
- modifying well settings
 - copying wells, [5-10](#)
 - cutting wells, [5-10](#)
 - pasting wells, [5-10](#)
- pasting
 - wells, [5-10](#)
- running
 - samples, [5-11](#)
- sample, [5-11](#)
- sample injection mode
 - selecting, [3-9](#)
- selecting
 - proper sample injection mode, [3-9](#)
- Workstation, [1-2, A-6](#)
 - component, [1-2](#)
- Workstation cannot be turned on, [9-8](#)
- workstation connections inspection
 - pre-boot, [3-4](#)
- worktable
 - installation environment validation, [A-2](#)

Beckman Coulter, Inc.

Customer End User License Agreement

This Product contains software that is owned by Beckman Coulter, Inc. or its suppliers and is protected by United States and international copyright laws and international trade provisions. You must treat the software contained in this Product like any other copyrighted material. This license and your right to use the Product terminate automatically if you violate any part of this agreement.

This is a license agreement and not an agreement for sale. Beckman Coulter hereby licenses this Software to you under the following terms and conditions:

You May:

1. Use this software in the computer supplied to you by Beckman Coulter;
2. Maintain one copy of this software for backup purposes (the backup copy shall be supplied by Beckman Coulter);
3. After written notification to Beckman Coulter, transfer the entire Product to another person or entity, provided you retain no copies of the Product software and the transferee agrees to the terms of this license agreement.

You May Not:

1. Use, copy or transfer copies of this Software except as provided in this license agreement;
2. Alter, merge, modify or adapt this Software in any way including disassembling or decompiling;
3. Loan, rent, lease, or sublicense this Software or any copy.

Limited Warranty

Beckman Coulter warrants that the software will substantially conform to the published specifications for the Product in which it is contained, provided that it is used on the computer hardware and in the operating system environment for which it was designed. Should the media on which your software arrives prove defective, Beckman Coulter will replace said media free of charge within 90 days of delivery of the Product. This is your sole remedy for any breach of warranty for this software.

Except as specifically noted above, Beckman Coulter makes no warranty or representation, either expressed or implied, with respect to this software or its documentation including quality, performance, merchantability, or fitness for a particular purpose.

No Liability for Consequential Damages

In no event shall Beckman Coulter or its suppliers be liable for any damages whatsoever (including, without limitation, damages for loss of profits, business interruption, loss of information, or other pecuniary loss) arising out of the use of or inability to use the Beckman Coulter Product software. Because some states do not allow the exclusion or limitation of liability for consequential damages, the above limitation might not apply to you.

General

This agreement constitutes the entire agreement between you and Beckman Coulter and supersedes any prior agreement concerning this Product software. It shall not be modified except by written agreement dated subsequent to the date of this agreement signed by an authorized Beckman Coulter representative. Beckman Coulter is not bound by any provision of any purchase order, receipt, acceptance, confirmation, correspondence, or otherwise, unless Beckman Coulter specifically agrees to the provision in writing. This agreement is governed by the laws of the State of California.

Related Documents

Operating Instructions

PN B49006

- Introduction
- System Overview
- Using the CytExpert Software
- Instrument Quality Control
- Data Acquisition and Sample Analysis
- Compensation
- Data Review
- Daily Shutdown
- Troubleshooting
- Cleaning Procedures
- Replacement/Adjustment Procedures
- Instrument Installation
- Table of Hazardous Substances
- Abbreviations

CytoFLEX Flow Cytometer Quick Start Guide

PN B49008

CytoFLEX Setup Guide

PN B53767

www.beckmancoulter.com

